

DH SERIES

DC Current Transducers
Ranges from 500 to 2000A
4-20mA Loop Powered
Bipolar Output

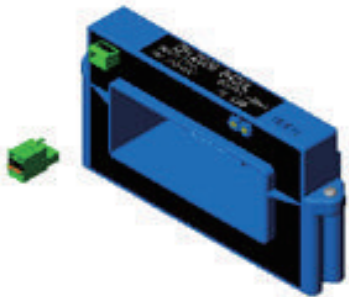

Installation guide
Manuel d'installation
Einbauvorschriften
導入ガイド

Important before to start

WARNING: Do not mix the top and bottom parts of these transducers!

The specified characteristics of the transducer are only guaranteed if the paired top and bottom parts are mounted together and not mixed with similar parts of other transducers.

In order to guarantee safe operation of the transducer and to be able to make proper use of all the features and functions, please read the following instructions thoroughly.

Installation

1. Mount the transducer to a surface if needed
Use M4 screws of adequate length and tighten to 0.8Nm +/-20% torque.
2. Connect output wiring. (see diagram)
Make sure connection is correct
3. Insert the wire in the transducer's hole.

Safety and warning notes

Safe operation can only be guaranteed if the transducer is used for the purpose it has been designed for and within the limits of the technical specifications. Ensure you get up-to-date technical information that can be found in the latest associated datasheet under www.lem.com.



Caution! Risk of danger

Ignoring the warnings can lead to serious injury and/or cause damage!
 The electric measuring transducer may only be installed and put into operation by qualified personnel that have received an appropriate training.
 The corresponding national regulations shall be observed during installation and operation of the transducer and any electrical conductor.
 The transducer shall be used in electric/electronic equipment with respect to applicable standards and safety requirements and in accordance with all the related systems and components manufacturer' operating instructions.



Caution! Risk of electrical shock

When operating the transducer, certain parts of the module may carry hazardous live voltage (e.g. primary conductor, power supply).
 The user shall ensure to take all measures necessary to protect against electrical shock.
 The transducer is a built-in device containing conducting parts that shall not be accessible after installation.
 A protective enclosure or additional insulation barrier may be necessary.
 The transducer shall not be put into operation if the jaw opening is open (split core version) or the installation is not completed.
 Installation and maintenance shall be done with the main power supply disconnected except if there are no hazardous live parts in or in close proximity to the system and if the applicable national regulations are fully observed.

Safe and trouble-free operation of this transducer can only be guaranteed if transport, storage and installation are carried out correctly and operation and maintenance are carried out with care.

Diagram

DH-B420L B

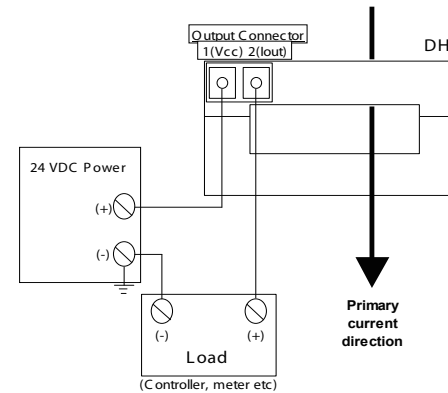

Transfer characteristics

Bipolar measurement of DC input

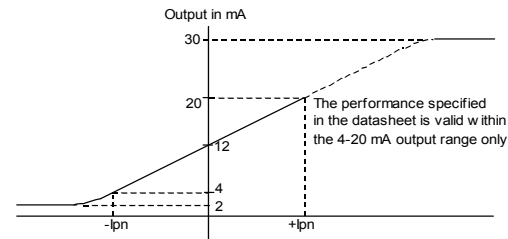

Isolation characteristics

V_b	Rms rated Voltage:	500	V
	with IEC 61010-1 standards and following conditions :		
	• Reinforced isolation		
	• Over voltage category CAT III		
	• Pollution degree PD2		
	• Heterogeneous field		
V_d	Rms voltage for AC isolation test, 50Hz, 1min	5.8	kV
ULXX	Plastic case classification	UL94-V0	



Specifications

Output signal	4-20 mA
Output Limit	30 mA
Frequency Range	only DC
Response time	1 ms to 90% of step change
Accuracy	1 % FS
Power Supply	20-30 V DC (loop powered)
Max Load Resistance	500 Ω with $V_c = +24$ V DC ¹⁾
Environmental	-10 to 70 °C -14 to 158 °F 0-95 % RH, non condensing

Note: ¹⁾ Max. Load Resistance vs. Supply Voltage

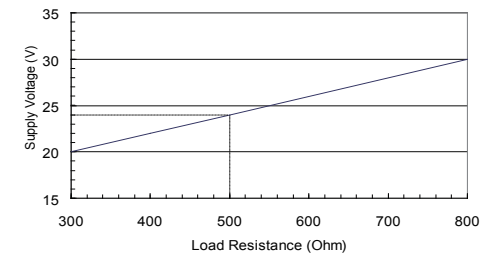

At the heart of power electronics

LEM is a market leader in providing innovative and high quality solutions for measuring electrical parameters. Its core products - current and voltage transducers - are used in a broad range of applications in industrial, traction, energy, automation and automotive markets.

For more information: www.lem.com



LEM S.A.
 8, chemin des Aulx
 CH-1228 Plan-les-Ouates
 Switzerland

Description

DH Series transducers combine a Hall effect technology and a signal conditioner into a single package. This provides higher accuracy, and save valuable panel space.

DH transducers are designed for measuring bipolar DC currents in application such as battery charge and discharge monitoring.

Trouble Shooting

1. Sensor has no output

- Polarity is not properly matched. Correct wiring polarity.
- Monitored load is not on or power supply is not on. Check that the monitored load is on and power supply for transducer is actually on
- Power supply is not properly sized. Check power supply voltage and current rating.

2. Output Signal Too Low

- Monitored current is below minimum required. Loop the monitored wire several times through the transducer until the "sensed" current rises above minimum.

Sensed Amps = (Actual Amps) x (Number of Loops). Count loops on the inside of the transducer.

3. Sensor is always at 12mA

Monitored load is not on. Check that the monitored load is actually on.

Description

La série de capteurs DH intègre la technologie à effet Hall et un conditionnement de signal dans un seul boîtier. Ceci permet une plus grande précision tout en économisant une place précieuse dans les panneaux de contrôle. Les capteurs de la famille DH sont adéquats pour la mesure des courants continus bipolaires tels que les courants de charge et de décharge de batteries.

Problèmes

1. Absence de signal de sortie

- La polarité n'est pas correcte. Vérifier et corriger la connexion du secondaire.
- Le courant mesuré est inexistant ou il n'est pas alternatif. Vérifier le fonctionnement de l'installation et que le courant primaire soit alternatif
- L'alimentation n'est pas adaptée. Vérifier la tension et le courant de l'alimentation.

2. Signal de sortie trop faible

- Le courant mesuré est inférieur au calibre minimum. Effectuer plusieurs tours du câble primaire autour du trou du capteur jusqu'à atteindre le calibre sélectionné. Courant mesuré = (courant primaire) x (Nombre de tours). Compter le nombre de fils qui passent à travers le trou.

3. Le capteur est toujours à 12mA

Le courant mesuré est inexistant. Vérifier le fonctionnement de l'installation primaire.

Beschreibung

Die Stromwandler der DH-Baureihe vereinigen die Hall-Effekt Technologie mit einer Signalaufbereitung in einem Gehäuse. Damit wird eine höhere Genauigkeit erreicht und wertvoller Platz im Schaltschrank gespart.

Die DH Wandler sind für die Messung von bipolaren Gleichströmen, z.B. in Anwendungen wie Batterielade- und Entladeüberwachung, entwickelt worden.

Fehlersuche

1. Wandler liefert kein Ausgangssignal

- Anschlüsse der Spannungsversorgung vertauscht. Polarität der Anschlüsse richtig stellen.
- Überwachte Last ist kein Wechselstromverbraucher oder ist nicht eingeschaltet. Stellen Sie sicher, dass es sich um einen Wechselstromverbraucher handelt und er eingeschaltet ist.
- Die Stromversorgung ist nicht richtig dimensioniert. Überprüfen Sie Nennspannung und Nennstrom der Stromversorgung.

2. Ausgangssignal zu niedrig

- Überwachter Strom ist unter dem erforderlichen Minimum. Führen Sie die Leitung mit dem zu überwachenden Strom mehrere Male durch die Öffnung bis der erforderliche Minimal Strom erreicht ist.
Gemessener Strom = (Strom im Leiter) x (Anzahl der Windungen). Für die Windungszahl ist die Anzahl der Leiter innerhalb der Öffnung maßgeblich.

3. Der Wandler liefert immer 12 mA

Die überwachte Last ist nicht eingeschaltet. Stellen Sie sicher, dass sie eingeschaltet ist.

特長

DH シリーズは、ホール素子技術と信号変換器を兼ね備えたトランスデューサです。高精であり、パネルスペースの節約が可能です。

DH トランスデューサは、両極の DC 電流の測定に適した設計となっており、バッテリーの供給と消費の監視などに使用できます。

トラブルシューティング

1. センサーの出力がでない

- 極性は一致していますか？配線が正しいかご確認ください。
- 入力信号が入力されていない、もしくは製品の供給電源が切れていませんか？入力信号が入力されており、かつ電源が入っていることをご確認ください。
- 電源は的確な値になっていますか？電源電圧と定格電流をご確認ください。

2. 出力信号が極端に低い

- 電流値を規定最小値より低くしていませんか？ワイヤーをトランスデューサ内に通し、電流値が規定値に上昇する巻数まで巻いてください。
電流値の目安 = (現在の電流値) x (巻数)
トランスデューサ内の巻数を数えてください。

3. センサーが常に 12mA になる

入力信号の電流源が切れていませんか？入力信号が入っていることをご確認ください。