

Current Transducer LA 25-NP/SP8

For the electronic measurement of currents: DC, AC, pulsed..., with galvanic separation between the primary circuit and the secondary circuit.

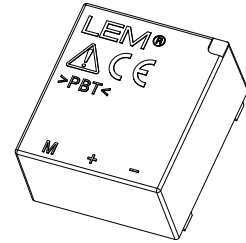

$$I_{PN} = 2 \text{ A}$$



Electrical data

I_{PN}	Primary nominal RMS current	2	A
I_{PM}	Primary current, measuring range	0 ... ± 3	A
R_M	Measuring resistance with $\pm 15 \text{ V}$		$R_{M \min}$ $R_{M \max}$
		@ $\pm 2 \text{ A}_{\max}$	100 320 Ω
		@ $\pm 3 \text{ A}_{\max}$	100 190 Ω
I_{SN}	Secondary nominal RMS current	24	mA
N_P/N_S	Turns ratio	12 : 1000	
U_C	Supply voltage ($\pm 5 \%$)	± 15	V
I_C	Current consumption	$10 + I_S$	mA

Accuracy - Dynamic performance data

ϵ_{tot}	Total error @ I_{PN} , $T_A = 25 \text{ }^\circ\text{C}$	± 0.5	%
ϵ_L	Linearity error	< 0.2	%
I_{OE}	Electrical offset current ¹⁾ @ $I_P = 0$, $T_A = 25 \text{ }^\circ\text{C}$	Typ	± 0.05 mA
		Max	± 0.15 mA
I_{OM}	Magnetic offset current ²⁾ @ $I_P = 0$ and specified R_M , after an overload of $3 \times I_{PN}$	Typ	± 0.05 mA
		Max	± 0.15 mA
I_{OT}	Temperature variation of I_O	0 $^\circ\text{C}$... +25 $^\circ\text{C}$	± 0.06 mA
		+25 $^\circ\text{C}$... +70 $^\circ\text{C}$	± 0.10 mA
t_{D90}	Delay time to 90 % of the final output value for I_{PN} step ³⁾ < 1		μs
BW	Frequency bandwidth (-1 dB)	DC ... 150	kHz

General data

T_A	Ambient operating temperature	0 ... +70	$^\circ\text{C}$
T_{Ast}	Ambient storage temperature	-25 ... +85	$^\circ\text{C}$
R_P	Resistance of primary (winding) @ $T_A = 25 \text{ }^\circ\text{C}$	< 12.4	m Ω
R_S	Resistance of secondary winding @ $T_A = 70 \text{ }^\circ\text{C}$	110	Ω
L_P	Insertion inductance	8	μH
R_{INS}	Insulation resistance @ 500 V, $T_A = 25 \text{ }^\circ\text{C}$	> 1500	M Ω
m	Mass	22	g
	Standard	EN 50178: 1997	

Notes: ¹⁾ Measurement carried out after 15 mn functioning
²⁾ The result of the coercive field of the magnetic circuit
³⁾ For a $di/dt = 50 \text{ A}/\mu\text{s}$.

Features

- Closed loop (compensated) current transducer using the Hall effect
- Insulating plastic case recognized according to UL 94-V0.

Special features

- $I_{PN} = 2 \text{ A}$
- $I_{PM} = 0 \dots \pm 3 \text{ A}$
- $N_P/N_S = 12 : 1000$.

Advantages

- Excellent accuracy
- Very good linearity
- Low temperature drift
- Optimized response time
- Wide frequency bandwidth
- No insertion losses
- High immunity to external interference
- Current overload capability.

Applications

- AC variable speed drives and servo motor drives
- Static converters for DC motor drives
- Battery supplied applications
- Uninterruptible Power Supplies (UPS)
- Switched Mode Power Supplies (SMPS)
- Power supplies for welding applications.

Application domain

- Industrial.

Current Transducer LA 25-NP/SP8

Insulation coordination

U_d	RMS voltage for AC insulation test, 50 Hz, 1 min	2.5	kV
U_{Ni}	Impulse withstand voltage 1.2/50 μ s	16	kV
		Min	
d_{Cp}	Creepage distance	19.5	mm
d_{Cl}	Clearance	19.5	mm
CTI	Comparative tracking index (group IIIa)	175	

Applications examples

According to EN 50178 and IEC 61010-1 standards and following conditions:

- Over voltage category OV 3
- Pollution degree PD2
- Non-uniform field

	EN 50178	IEC 61010-1
d_{Cp}, d_{Cl}, U_{Ni}	Rated insulation voltage	Nominal voltage
Basic insulation	1700 V	1700 V
Reinforced insulation	600 V	600 V

Safety

This transducer must be used in limited-energy secondary circuits according to IEC 61010-1.



This transducer must be used in electric/electronic equipment with respect to applicable standards and safety requirements in accordance with the manufacturer's operating instructions.



Caution, risk of electrical shock

When operating the transducer, certain parts of the module can carry hazardous voltage (eg. primary busbar, power supply).

Ignoring this warning can lead to injury and/or cause serious damage.

This transducer is a build-in device, whose conducting parts must be inaccessible after installation.

A protective housing or additional shield could be used.

Main supply must be able to be disconnected.

Dimensions LA 25-NP/SP8 (in mm)

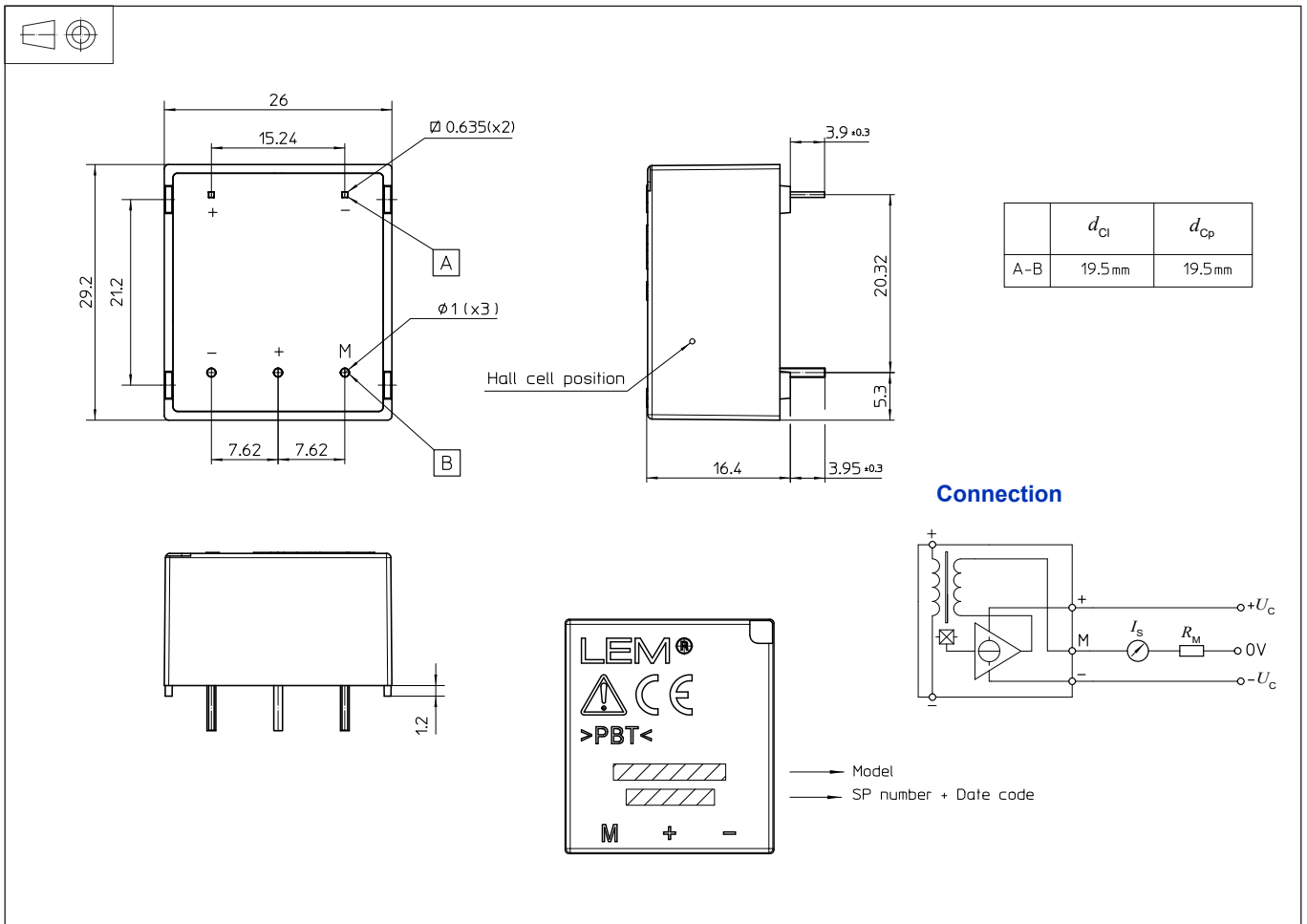

Mechanical characteristics

- General tolerance ± 0.2 mm
- Fastening & connection of primary 2 pins
0.635 × 0.635 mm
- Fastening & connection of secondary 3 pins $\varnothing 1$ mm
- Recommended PCB hole 1.2 mm

Remark

- I_S is positive when I_p flows from terminal + to terminal -.