

Current Transducer LA 55-TP/SP1

For the electronic measurement of currents: DC, AC, pulsed..., with galvanic isolation between the primary circuit (high power) and the secondary circuit (electronic circuit).

$I_{PN} = 50 \text{ A}$

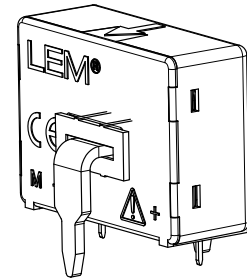

Electrical data

| | | | | | | | | |
|----------|----------------------------------|--------------------------|--------------------------|--------------------------|--------------|-----|-----|---|
| I_{PN} | Primary nominal current rms | 50 | A | | | | | |
| I_{PM} | Primary current, measuring range | 0 .. ± 100 | A | | | | | |
| R_M | Measuring resistance @ | $T_A = 70^\circ\text{C}$ | | $T_A = 85^\circ\text{C}$ | | | | |
| | | $R_{M \min}$ | $R_{M \max}$ | $R_{M \min}$ | $R_{M \max}$ | | | |
| | | with ± 12 V | @ ± 50 A _{max} | 0 | 215 | 0 | 210 | Ω |
| | | | @ ± 100 A _{max} | 0 | 35 | 0 | 30 | Ω |
| | with ± 15 V | @ ± 50 A _{max} | 0 | 335 | 70 | 330 | Ω | |
| | | @ ± 100 A _{max} | 0 | 95 | 70 | 90 | Ω | |
| I_{SN} | Secondary nominal current rms | 25 | mA | | | | | |
| K_N | Conversion ratio | 1 : 2000 | | | | | | |
| V_C | Supply voltage (± 5 %) | ± 12 .. 15 | V | | | | | |
| I_C | Current consumption | 10 (@ ± 15 V) + I_S | mA | | | | | |

Accuracy - Dynamic performance data

| | | | | | | |
|--------------------------------|--|------------------------|-----------|--------|--------|----|
| X | Accuracy @ I_{PN} , $T_A = 25^\circ\text{C}$ | @ ± 15 V (± 5 %) | ± 0.65 | % | | |
| | | @ ± 12 .. 15 V (± 5 %) | ± 0.90 | % | | |
| ϵ_L | Linearity error | | < 0.15 | % | | |
| I_O | Offset current @ $I_p = 0$, $T_A = 25^\circ\text{C}$ | Typ | | ± 0.10 | mA | |
| | | Max | | ± 0.15 | mA | |
| I_{OM} | Magnetic offset current ¹⁾ @ $I_p = 0$ and specified R_{M1} after an overload of 3 x I_{PN} | | | ± 0.05 | ± 0.30 | mA |
| I_{OT} | Temperature variation of I_O | - 25°C .. + 85°C | ± 0.05 | ± 0.30 | mA | |
| | | - 40°C .. - 25°C | ± 0.10 | ± 0.50 | mA | |
| t_{ra} | Reaction time to 10 % of I_{PN} step | | < 500 | ns | | |
| t_r | Response time ²⁾ to 90 % of I_{PN} step | | < 1 | µs | | |
| di/dt | di/dt accurately followed | | > 200 | A/µs | | |
| BW | Frequency bandwidth (- 1 dB) | | DC .. 200 | kHz | | |

General data

| | | | | |
|----------|-------------------------------|----------------------------|-----|---|
| T_A | Ambient operating temperature | - 40 .. + 85 | °C | |
| T_S | Ambient storage temperature | - 40 .. + 90 | °C | |
| R_S | Secondary coil resistance | @ $T_A = 70^\circ\text{C}$ | 145 | Ω |
| | | @ $T_A = 85^\circ\text{C}$ | 150 | Ω |
| m | Mass | 25 | g | |
| | Standards | EN 50178: 1997 | | |

Notes: ¹⁾ Result of the coercive field of the magnetic circuit

²⁾ With a di/dt of 100 A/µs.

Features

- Closed loop (compensated) current transducer using the Hall effect
- Printed circuit board mounting
- Insulated plastic case recognized according to UL 94-V0.

Special features

- $I_{PM} = 0 \dots \pm 100 \text{ A}$
- $K_N = 1 : 2000$.

Advantages

- Excellent accuracy
- Very good linearity
- Low temperature drift
- Optimized response time
- Wide frequency bandwidth
- No insertion losses
- High immunity to external interference
- Current overload capability.

Applications

- AC variable speed drives and servo motor drives
- Static converters for DC motor drives
- Battery supplied applications
- Uninterruptible Power Supplies (UPS)
- Switched Mode Power Supplies (SMPS)
- Power supplies for welding applications.

Application domain

- Industrial.

Current Transducer LA 55-TP/SP1

Isolation characteristics

| | | | |
|-------------|---|-----|----|
| V_d | Rms voltage for AC isolation test, 50 Hz, 1 min | 2.5 | kV |
| \hat{V}_w | Impulse withstand voltage 1.2/50 μ s | 7.5 | kV |
| | | Min | |
| dCp | Creepage distance | 7.5 | mm |
| dCI | Clearance distance | 7.5 | mm |
| CTI | Comparative Tracking Index (group IIIa) | 175 | |

Applications examples

According to **EN 50178** and **IEC 61010-1** standards and following conditions:

- Over voltage category OV 3
- Pollution degree PD2
- Non-uniform field

| | EN 50178 | IEC 61010-1 |
|---|-------------------------|-----------------|
| dCp, dCI, \hat{V}_w | Rated isolation voltage | Nominal voltage |
| Single isolation | 600 V | 600 V |
| Reinforced isolation | 300 V | 300 V |

Safety



This transducer must be used in electric/electronic equipment with respect to applicable standards and safety requirements in accordance with the manufacturer's operating instructions.



Caution, risk of electrical shock

When operating the transducer, certain parts of the module can carry hazardous voltage (eg. primary busbar, power supply).

Ignoring this warning can lead to injury and/or cause serious damage.

This transducer is a build-in device, whose conducting parts must be inaccessible after installation.

A protective housing or additional shield could be used.

Main supply must be able to be disconnected.

Dimensions LA 55-TP/SP1 (in mm. 1 mm = 0.0394 inch)

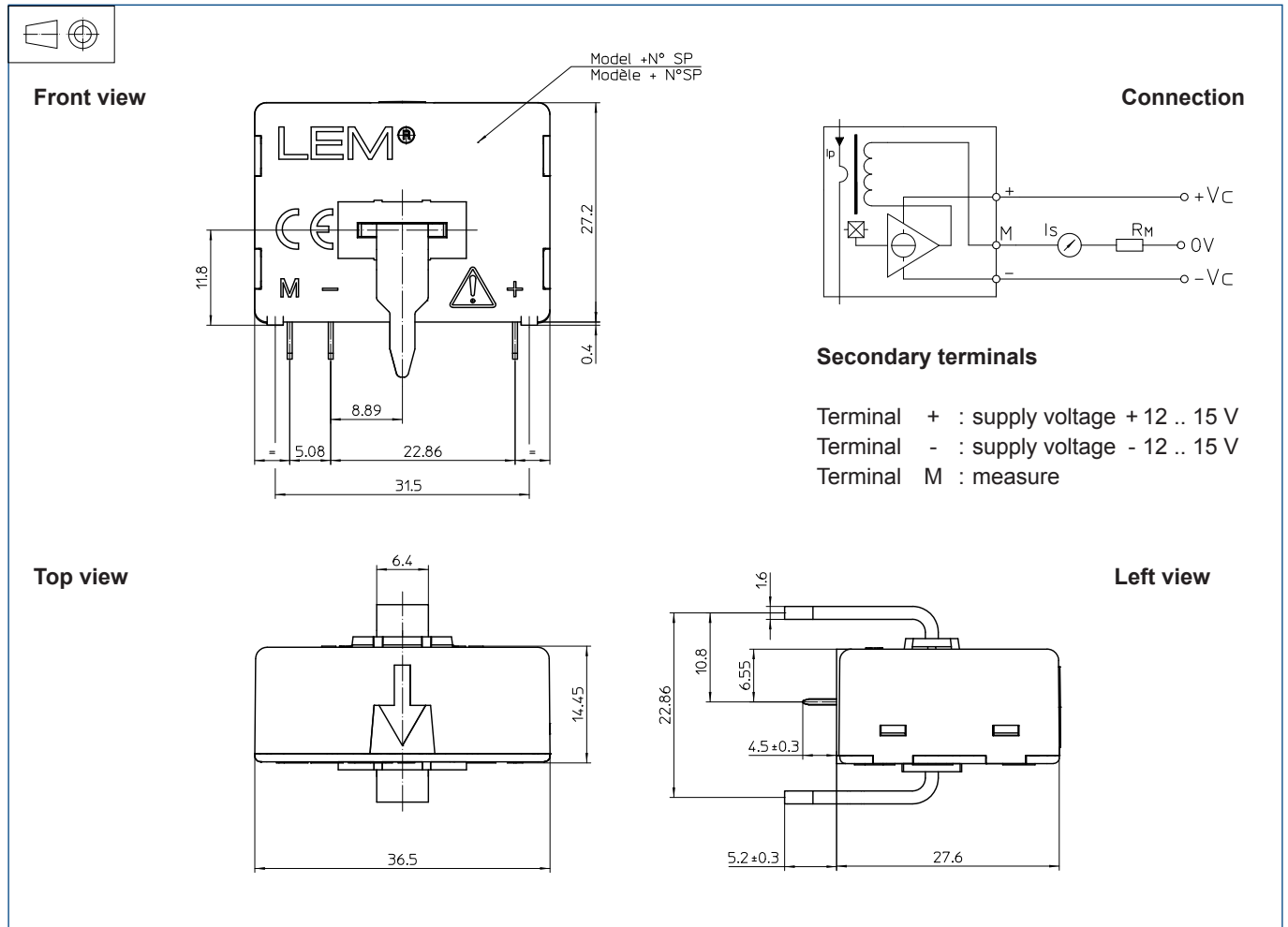

Mechanical characteristics

- General tolerance ± 0.2 mm
- Fastening & connection of primary bus bar
6.4 x 1.6 mm
- Recommended PCB hole 3.8 mm
- Fastening & connection of secondary 3 pins
0.63 x 0.56 mm
- Recommended PCB hole 0.9 mm

Remarks

- I_s is positive when I_p flows in the direction of the arrow.
- Temperature of the primary conductor should not exceed 90°C.