

# Current Transducer LF 2005-S/SP9

For the electronic measurement of currents: DC, AC, pulsed..., with galvanic isolation between the primary circuit and the secondary circuit.

$$I_{PN} = 1000 \text{ A}$$



## Electrical data

$I_{PN}$	Primary nominal current rms	1000	A	
$I_{PM}$	Primary current, measuring range @ $\pm 24 \text{ V}$	0 .. $\pm 2000$	A	
$I_P$	Overload capability @ 250 $\mu\text{s}$	50	kA	
$R_M$	Measuring resistance			
		$T_A = 70^\circ\text{C}$	$T_A = 85^\circ\text{C}$	
		$R_{M \min}$ $R_{M \max}$	$R_{M \min}$ $R_{M \max}$	$\Omega$
	with $\pm 15 \text{ V}$ @ $\pm 1000 \text{ A}_{\max}$	0 27	0 26	$\Omega$
	@ $\pm 1700 \text{ A}_{\max}$	0 2	0 1	$\Omega$
with $\pm 24 \text{ V}$ @ $\pm 1000 \text{ A}_{\max}$	0 69	3 68	$\Omega$	
@ $\pm 2000 \text{ A}_{\max}$	0 18	3 17	$\Omega$	
$I_{SN}$	Secondary nominal current rms	200	mA	
$K_N$	Conversion ratio	1 : 5000		
$V_C$	Supply voltage ( $\pm 10\%$ )	$\pm 15 \dots 24$	V	
$I_C$	Current consumption	33 (@ $\pm 24 \text{ V}$ ) + $I_S$	mA	

## Accuracy - Dynamic performance data

$\epsilon_L$	Linearity error	< 0.1	%
$t_r$	Response time <sup>1)</sup> to 90 % of $I_{PN}$ step	< 1	$\mu\text{s}$
$di/dt$	$di/dt$ accurately followed	> 100	A/ $\mu\text{s}$
<b>BW</b>	Frequency bandwidth (- 1 dB)	DC .. 100	kHz

## Test circuit

$N_T$	Number of turns	1000	
$R_T$	Resistance of test circuit @ $T_A = 85^\circ\text{C}$	16	$\Omega$
$I_T$	Test current	0.1 <sup>2)</sup>	A

### Remarks:

- Use a current generator for the test winding (high impedance)
- Otherwise a minimum resistance in series with the test winding is needed:
  - 30  $\Omega$  @  $T_A = -25 \dots +85^\circ\text{C}$
  - 50  $\Omega$  @  $T_A = -40 \dots +85^\circ\text{C}$

## General data

$T_A$	Ambient operating temperature	- 40 .. + 85	$^\circ\text{C}$
$T_S$	Ambient storage temperature	- 40 .. + 85	$^\circ\text{C}$
$R_S$	Secondary coil resistance	@ $T_A = 70^\circ\text{C}$	33 $\Omega$
		@ $T_A = 85^\circ\text{C}$	34 $\Omega$
$m$	Mass	1.4	kg
	Standards	EN 50155: 2001	

- Notes:**
- <sup>1)</sup> With a  $di/dt$  of 100 A/ $\mu\text{s}$
  - <sup>2)</sup> Maximum 1 A during 10 seconds 6 times per hour
  - <sup>3)</sup> Between primary and secondary + test.

## Features

- Closed loop (compensated) current transducer using the Hall effect
- Isolated plastic case recognized according to UL 94-V0.

## Special features

- $I_{PN} = 1000 \text{ A}$
- $I_{PM} = 0 \dots \pm 2000 \text{ A}$
- $V_C = \pm 15 \dots 24 (\pm 10\%) \text{ V}$
- $V_d = 12 \text{ kV}^{3)}$
- $N_T = 1000$  turns
- $T_A = -40^\circ\text{C} \dots 85^\circ\text{C}$
- Secondary connection on shielded cable 5 x 0.5 mm<sup>2</sup>.

## Advantages

- Excellent accuracy
- Very good linearity
- Low temperature drift
- Optimized response time
- Wide frequency bandwidth
- No insertion losses
- High immunity to external interference
- Current overload capability.

## Applications

- Single or three phases inverter
- Propulsion and braking chopper
- Propulsion converter
- Auxiliary converter
- Battery charger.

## Application Domain

- Traction.

## Current Transducer LF 2005-S/SP9

### Isolation characteristics

$V_d$	Rms voltage for AC isolation test, 50 Hz, 1 min	12 <sup>1)</sup> 500 <sup>2)</sup>	kV V
$V_e$	Rms voltage for partial discharge extinction @ 10 pC	$\geq 4.1$ <sup>3)</sup> Min	kV
<b>dCp</b>	Creepage distance	51.5	mm
<b>dCl</b>	Clearance	51.5	mm
<b>CTI</b>	Comparative Tracking Index (group I)	600	

**Notes:** <sup>1)</sup> Between primary and secondary + test  
<sup>2)</sup> Between shield and secondary + test  
<sup>3)</sup> Test performed with a non-insulated bus bar (dimension 290 x 50 x 10 mm) centered in the aperture.

### DC offset [At]

Temperature range	Maximum range of measured current			
	- 100 .. + 100 A	- 500 .. + 500 A	- 1000 .. + 1000 A	- 2000 .. + 2000 A
- 25°C .. + 85°C	$\pm 3.6$	$\pm 3.8$	$\pm 4.0$	$\pm 4.8$
- 40°C .. + 85°C	$\pm 5.1$	$\pm 5.3$	$\pm 5.5$	$\pm 6.3$

Maximum DC offset for different ranges of temperature and measured current.

### Wiring plan for DC component measuring

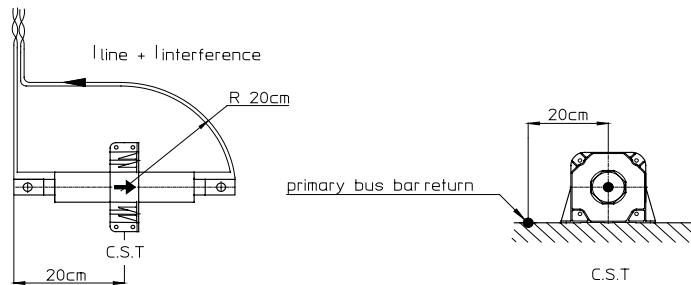

### Accuracy for the measurement of a single frequency signal

Frequency	20 .. 200 Hz		200 .. 3000 Hz	
	Amplitude Error [%]	Phase Error [%]	Amplitude Error [%]	Phase Error [%]
0.1 .. 0.5 A	$\pm 55$	- 15.0	$\pm 55$	22
0.5 .. 1 A	$\pm 17$	- 14.0	$\pm 48$	22
1 .. 2 A	$\pm 7.0$	- 7.4	$\pm 32$	14
2 .. 10 A	$\pm 6.6$	- 1.6	$\pm 17$	6.2
10 .. 20 A	$\pm 3.7$	< - 1.0	$\pm 6.8$	- 1.4
20 .. 50 A	$\pm 2.8$	< - 1.0	$\pm 3.6$	< - 1.0

Amplitude error: in % of the measured signal.  
Phase error: in degrees with respect to the measured signal.  
Maximum amplitude and phase errors for single frequency signals.  
High error values are due to zero-crossing distortion.

### Accuracy for the measurement of a signals added to a DC current $\geq 10$ A

Frequency	20 .. 200 Hz		200 .. 3000 Hz	
	Amplitude Error [%]	Phase Error [%]	Amplitude Error [%]	Phase Error [%]
0.1 .. 0.5 A	$\pm 2.2$	- 1.6	$\pm 4.4$	1.4
0.5 .. 1 A	$\pm 2.5$	- 1.6	$\pm 4.1$	< - 1.0
1 .. 2 A	$\pm 2.5$	- 1.6	$\pm 4.1$	< - 1.0
2 .. 10 A	$\pm 6.1$	- 1.1	$\pm 7.0$	< - 1.0
10 .. 20 A	$\pm 6.1$	< - 1.0	$\pm 8.8$	< - 1.0
20 .. 50 A	$\pm 6.0$	< - 1.0	$\pm 7.5$	< - 1.0

Amplitude error: in % of the measured signal.

Phase error: in degrees with respect to the measured signal.

Maximum amplitude and phase errors for signals added to a DC fundamental.

### Accuracy for the measurement of a signals added to an AC (fundamental) current ( $15 \text{ Hz} < f < 100 \text{ Hz}$ ), $\geq 10$ A rms

Frequency	20 .. 200 Hz		200 .. 3000 Hz	
	Amplitude Error [%]	Phase Error [%]	Amplitude Error [%]	Phase Error [%]
0.1 .. 0.5 A	$\pm 1.6$	< - 1.0	$\pm 2.3$	< - 1.0
0.5 .. 1 A	$\pm 1.2$	< - 1.0	$\pm 1.9$	< - 1.0
1 .. 2 A	$\pm 0.9$	< - 1.0	$\pm 1.3$	< - 1.0
2 .. 10 A	$\pm 0.6$	< - 1.0	$\pm 0.8$	< - 1.0
10 .. 20 A	$\pm 0.6$	< - 1.0	$\pm 0.7$	< - 1.0
20 .. 50 A	$\pm 1.0$	< - 1.0	$\pm 1.0$	< - 1.0

Amplitude error: in % of the measured signal.

Phase error: in degrees with respect to the measured signal.

Maximum amplitude and phase errors for signals added to an AC fundamental.

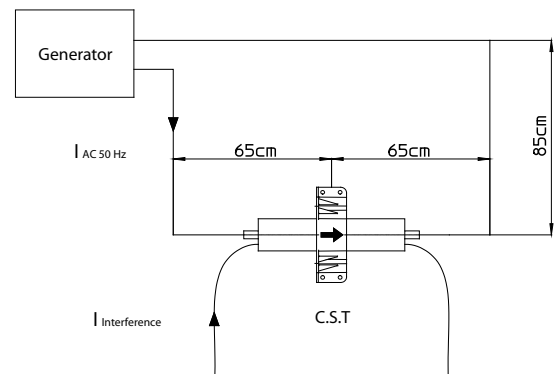

Wiring plan for measurements with an AC component.

### Influence regarding external magnetic fields

Frequency	0 .. 5 Hz	
	Max error [mAt <sub>rms</sub> per A/m]	Max error [mAt <sub>rms</sub> per A/m]
X-axis	0.16	0.18
Y-axis	3.3	5.3
Z-axis	0.04	0.08

Error in the measurement of the primary current [mA<sub>rms</sub>] due to external magnetic fields at the specified frequencies for the three axes of the transducer

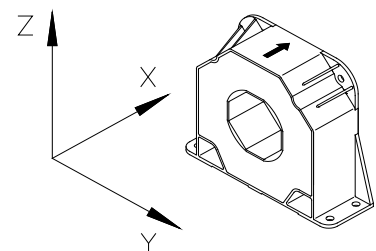

Orientation of transducer during magnetic field sensitivity testing.

## Dimensions LF 2005-S/SP9 (in mm)

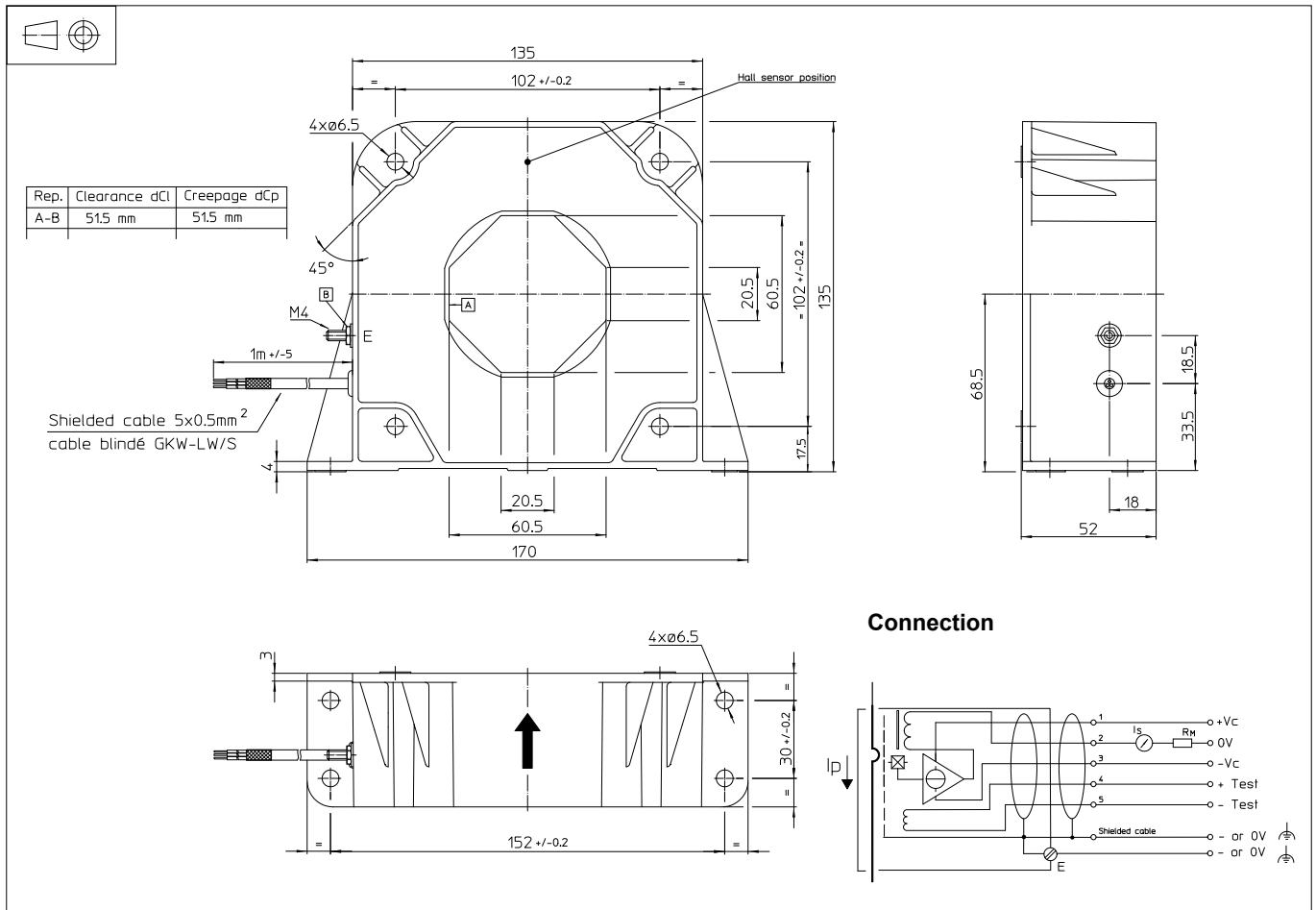

### Mechanical characteristics

- General tolerance  $\pm 0.5$  mm
- Transducer fastening  
Vertical or flat position 4 holes  $\varnothing 6.5$  mm,  
4 M6 steel screws
- Recommended fastening torque 4.2 Nm
- Primary through-hole 60.5 x 20.5  
Or  $\varnothing 56$  mm max
- Connection of secondary shielded cable  
5 x 0.5 mm<sup>2</sup>
- Connection shields M4 threaded stud  
Recommended fastening torque 1.2 Nm

### Remarks

- $I_s$  is positive when  $I_p$  flows in the direction of the arrow.
- Temperature of the primary conductor should not exceed 100°C.
- Dynamic performances (di/dt and response time) are best with a single bar completely filling the primary hole.

### Safety



This transducer must be used in electric/electronic equipment with respect to applicable standards and safety requirements in accordance with the manufacturer's operating instructions.



Caution, risk of electrical shock

When operating the transducer, certain parts of the module can carry hazardous voltage (eg. primary busbar, power supply). Ignoring this warning can lead to injury and/or cause serious damage.

This transducer is a build-in device, whose conducting parts must be inaccessible after installation.

A protective housing or additional shield could be used.

Main supply must be able to be disconnected.