

Current Transducer LT 4000-T/SP37

$$I_{PN} = 4000 \text{ A}$$

For the electronic measurement of currents : DC, AC, pulsed..., with a galvanic isolation between the primary circuit (high power) and the secondary circuit (electronic circuit).



0708

Electrical data

I_{PN}	Primary nominal r.m.s. current	4000	A			
I_p	Primary current, measuring range	0 .. ± 5650	A			
R_M	Measuring resistance	R_{Mmin}	R_{Mmax}			
		with $\pm 24 \text{ V}$	@ $\pm 4000 \text{ A}_{max}$	0	11	Ω
			@ $\pm 5650 \text{ A}_{max}$	0	3.5	Ω
I_{SN}	Secondary nominal r.m.s. current	800	mA			
K_N	Conversion ratio	1 : 5000				
V_C	Supply voltage ($\pm 5 \%$)	± 24	V			
I_C	Current consumption	$35 + I_s$	mA			
V_d	R.m.s. voltage for AC isolation test, 50 Hz, 1 mn	9 ¹⁾	kV			
		1 ²⁾	kV			
V_e	R.m.s. voltage for partial discharge extinction @ 10 pC	8.35	kV			
\hat{V}_i	Impulse voltage (1.2 / 50 μs)	41	kV			
LS	Clearance distance	> 62	mm			
KS	Creepage distance	> 106	mm			

Features

- Closed loop (compensated) current transducer using the Hall effect
- Isolated plastic case recognized according to UL 94-V0.

Special features

- $I_p = 0 .. \pm 5650 \text{ A}$
- Internal shield linked to the external shield
- Shield around the secondary connection
- Primary busbar with cylindrical mid-section $\varnothing 60 \text{ mm}$.

Advantages

- Excellent accuracy
- Very good linearity
- Low temperature drift
- Optimized response time
- Wide frequency bandwidth
- No insertion losses
- High immunity to external interference
- Current overload capability.

Applications

- AC variable speed drives and servo motor drives
- Static converters for DC motor drives
- Battery supplied applications
- Uninterruptible Power Supplies (UPS)
- Switched Mode Power Supplies (SMPS)
- Power supplies for welding applications.

Accuracy - Dynamic performance data

X	Accuracy @ $I_{PN}, T_A = 25^\circ\text{C}$	± 0.2	%	
\mathcal{E}_L	Linearity error	< 0.1	%	
I_O	Offset current @ $I_p = 0, T_A = 25^\circ\text{C}$	Typ	Max	
			± 0.8	mA
I_{OT}	Thermal drift of I_O - $25^\circ\text{C} .. +70^\circ\text{C}$	± 0.6	± 0.8	mA
t_r	Response time ³⁾ @ 90 % of I_{PN}	< 1	μs	
di/dt	di/dt accurately followed	> 50	A/ μs	
f	Frequency bandwidth (- 1 dB)	DC .. 100	kHz	

General data

T_A	Ambient operating temperature	- 25 .. + 70	$^\circ\text{C}$
T_S	Ambient storage temperature	- 40 .. + 85	$^\circ\text{C}$
R_S	Secondary coil resistance @ $T_A = 70^\circ\text{C}$	15	Ω
m	Mass	12.1	kg
	Standards	EN 50178: 1997	

Notes: 1) Between primary and secondary + shield
 2) Between secondary and shield
 3) With a di/dt of 100 A/ μs .

070301/6

Dimensions LT 4000-T/SP37 (in mm. 1 mm = 0.0394 inch)

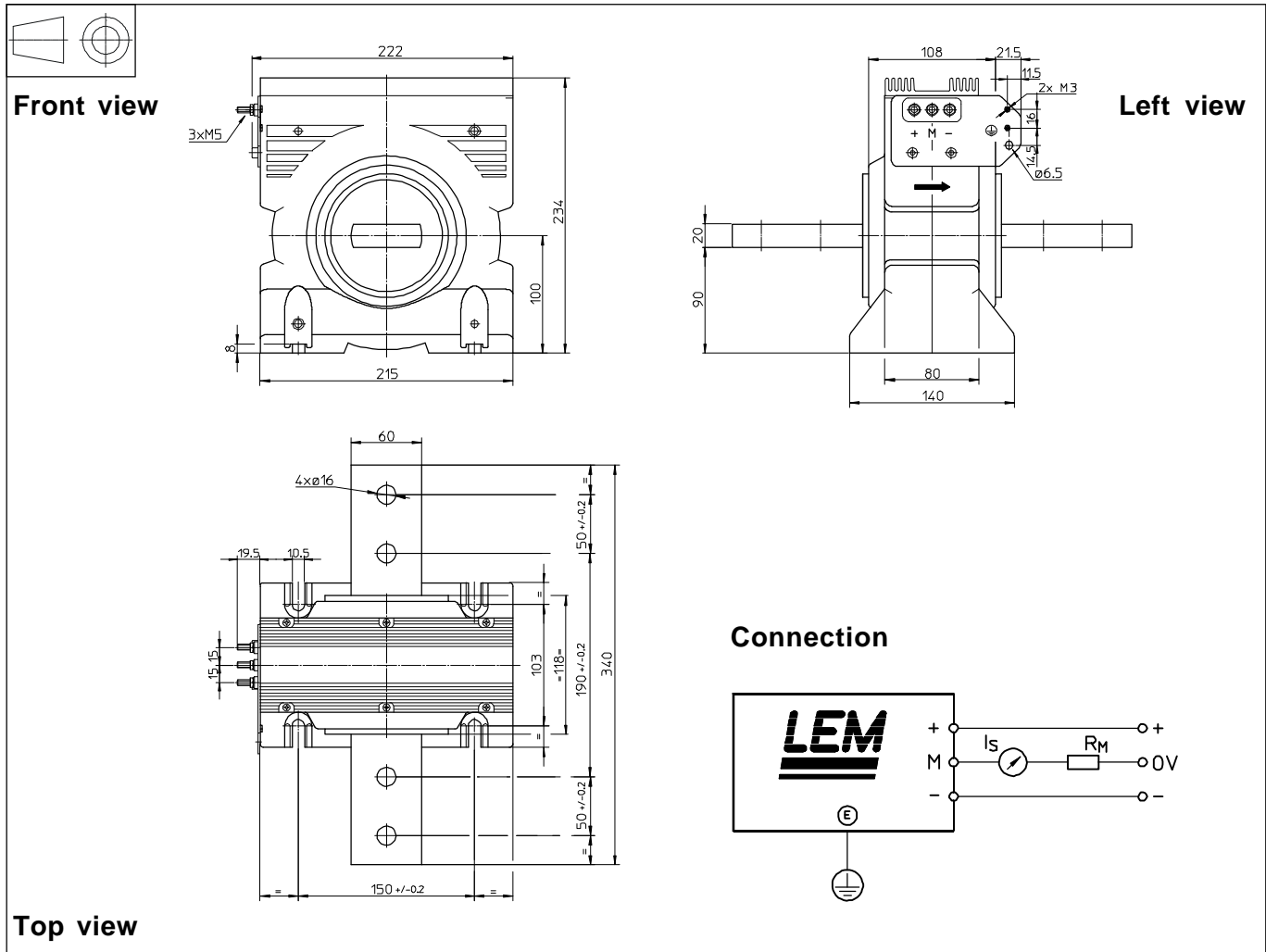

Mechanical characteristics

- General tolerance ± 1 mm
- Transducer fastening using primary bar or 4 slots $\varnothing 10.5$ mm
4 M10 steel screws
Recommended fastening torque 11.5 Nm or 8.48Lb - Ft
- Connection of primary 4 holes $\varnothing 16$ mm
4 M12 steel screws
Recommended fastening torque 24.5 Nm or 18 Lb - Ft
- Connection of secondary M5 threaded studs
Recommended fastening torque 2.2 Nm or 1.62 Lb - Ft
- Earth connection holes $\varnothing 6.5$ mm and/
or 2 screws M3

Remarks

- I_S is positive when I_p flows in the direction of the arrow.
- Temperature of the primary conductor should not exceed 100°C.