

Current Transducer LTC 1000-SF/SP4

For the electronic measurement of currents: DC, AC, pulsed..., with galvanic isolation between the primary circuit and the secondary circuit.

$$I_{PN} = 1000 \text{ A}$$



Electrical data

I_{PN}	Primary nominal current rms	1000	A	
I_{PM}	Primary current, measuring range @ $\pm 24 \text{ V}$	0 .. ± 3000	A	
R_M	Measuring resistance	$R_{M \min}$ $R_{M \max}$		
				with $\pm 15 \text{ V}$
		@ $\pm 1200 \text{ A}_{\max}$	0 10	Ω
	with $\pm 24 \text{ V}$	@ $\pm 1000 \text{ A}_{\max}$	2 60	Ω
	@ $\pm 3000 \text{ A}_{\max}$	2 2	Ω	
I_{SN}	Secondary nominal current rms	250	mA	
K_N	Conversion ratio	1 : 4000		
V_C	Supply voltage ($\pm 5\%$)	$\pm 15 \dots 24$	V	
I_C	Current consumption	$< 31 (@ \pm 24 \text{ V}) + I_S$	mA	

Accuracy - Dynamic performance data

X_G	Overall accuracy	@ $I_{PN}, T_A = 25^\circ\text{C}$	$< \pm 0.4$	%
ε_L	Linearity error		< 0.1	%
			Max	
I_O	Offset current @ $I_p = 0, T_A = 25^\circ\text{C}$		± 0.5	mA
I_{OT}	Temperature variation of I_O	- $40^\circ\text{C} \dots + 85^\circ\text{C}$	± 1	mA
t_r	Response time ¹⁾ to 90 % of I_{PN} step		< 1	μs
di/dt	di/dt accurately followed		> 100	A/ μs
BW	Frequency bandwidth (- 1 dB)		DC .. 100	kHz

General data

T_A	Ambient operating temperature	- 40 .. + 85	$^\circ\text{C}$
T_S	Ambient storage temperature	- 50 .. + 90	$^\circ\text{C}$
R_S	Secondary coil resistance @ $T_A = 85^\circ\text{C}$	26	Ω
m	Mass	900	g
	Standard	EN 50155: 2001	

Note: ¹⁾ With a di/dt of 100 A/ μs .

Features

- Closed loop (compensated) current transducer using the Hall effect
- Isolated plastic case recognized according to UL 94-V0.

Special features

- $I_{PM} = 0 \dots \pm 3000 \text{ A}$
- $K_N = 1 : 4000$
- Connection to secondary circuit on 10-24 UNC threaded studs
- Mounting feet compatible with LT 1000-SI/SP66.

Advantages

- Excellent accuracy
- Very good linearity
- Low temperature drift
- Optimized response time
- Wide frequency bandwidth
- No insertion losses
- High immunity to external interference
- Current overload capability.

Applications

- Single or three phase inverters
- Propulsion and braking chopper
- Propulsion converter
- Auxiliary converter
- Battery charger.

Application Domain

- Traction.

Current Transducer LTC 1000-SF/SP4

Isolation characteristics

V_d	Rms voltage for AC insulation test, 50 Hz, 1 min	13.4	kV
V_e	Partial discharge extinction voltage rms @ 10 pC	2.8	kV
dCp	Creepage distance	Min 51.15	mm
dCl	Clearance	73.87	mm
CTI	Comparative Tracking Index (group I)	600	

Safety



This transducer must be used in electric/electronic equipment with respect to applicable standards and safety requirements in accordance with the manufacturer's operating instructions.



Caution, risk of electrical shock

When operating the transducer, certain parts of the module can carry hazardous voltage (eg. primary busbar, power supply).

Ignoring this warning can lead to injury and/or cause serious damage.

This transducer is a build-in device, whose conducting parts must be inaccessible after installation.

A protective housing or additional shield could be used.

Main supply must be able to be disconnected.

Dimensions LTC 1000-SF/SP4 (in mm)

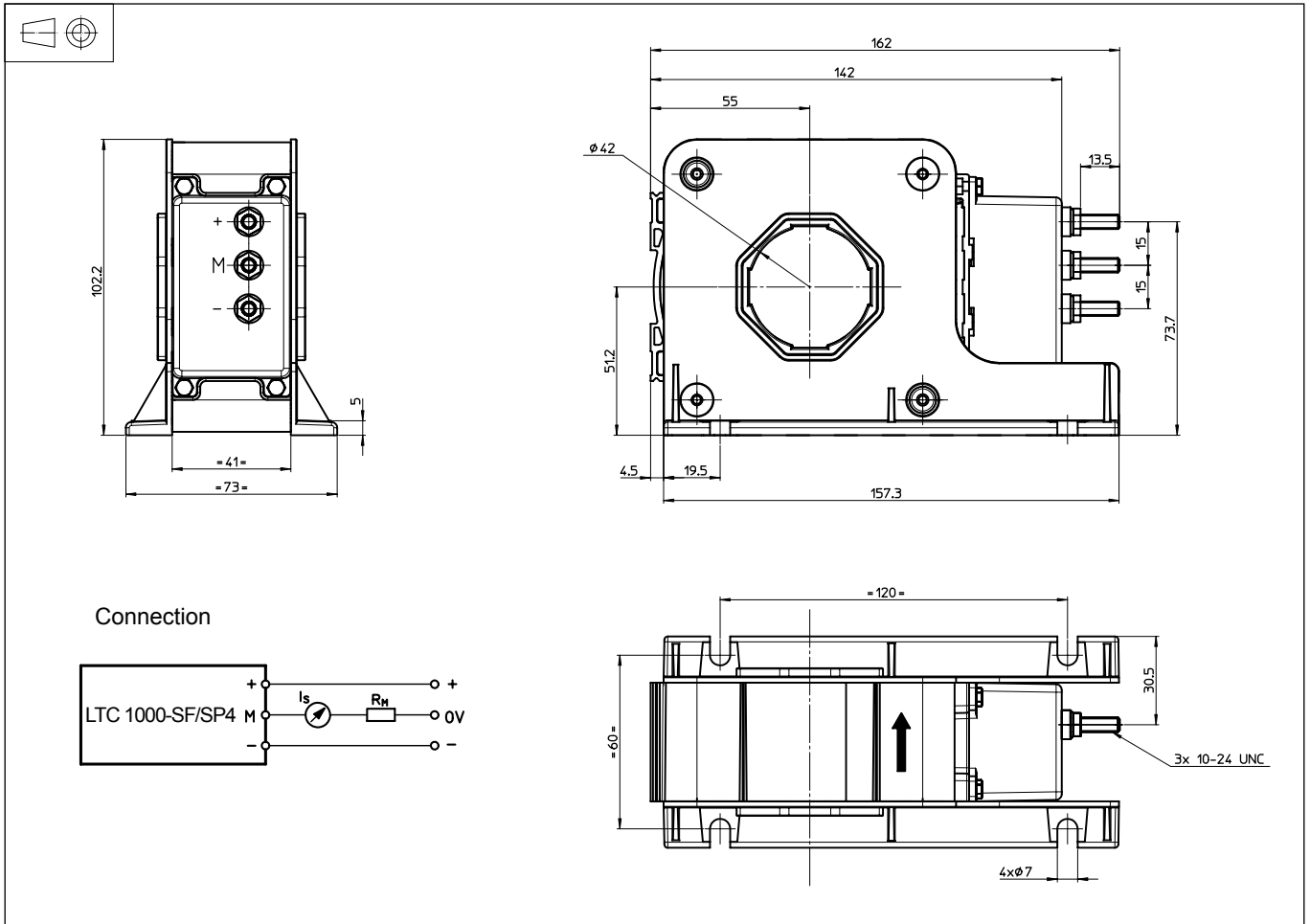

Mechanical characteristics

- General tolerance ± 1 mm
- Transducer fastening
 - 4 slots $\phi 7.0$ mm
 - 4 steel screws M6
- Recommended fastening torque 4.7 Nm
- Primary through-hole $\phi 42$ mm
- Connection of secondary 10-24 UNC threaded studs
- Recommended fastening torque 2.2 Nm
- Faston 6.3 x 0.8 mm

Remarks

- I_s is positive when I_p flows in the direction of the arrow.
- Temperature of the primary conductor should not exceed 100°C .
- Dynamic performances (di/dt and response time) are best with a single bar completely filling the primary hole.