

Current Transducer LTC 500-SFC/SP2

For the electronic measurement of currents: DC, AC, pulsed..., with galvanic isolation between the primary circuit and the secondary circuit.

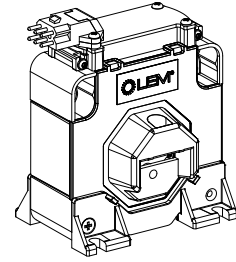

$I_{PN} = 500 \text{ A}$



Electrical data

| | | | | | | |
|----------|---|--|------------------------------|-------------------------|------------------------------|----------|
| I_{PN} | Primary nominal current rms | 500 | A | | | |
| I_{PM} | Primary current, measuring range @ $\pm 24 \text{ V}$ | 0 .. ± 1200 | A | | | |
| R_M | Measuring resistance | $R_{M \min}$ | $R_{M \max}$ | | | |
| | | | | with $\pm 15 \text{ V}$ | @ $\pm 500 \text{ A}_{\max}$ | 0 |
| | | | @ $\pm 900 \text{ A}_{\max}$ | 0 | 7 | Ω |
| | | with $\pm 24 \text{ V}$ | @ $\pm 500 \text{ A}_{\max}$ | 0 | 110 | Ω |
| | @ $\pm 1200 \text{ A}_{\max}$ | 0 | 20 | Ω | | |
| I_{SN} | Secondary nominal current rms | 125 | mA | | | |
| K_N | Conversion ratio | 1 : 4000 | | | | |
| V_C | Supply voltage ($\pm 5 \%$) | $\pm 15 \dots 24$ | V | | | |
| I_C | Current consumption | < 35 (@ $\pm 24 \text{ V}$) + I_S | mA | | | |

Accuracy - Dynamic performance data

| | | | |
|-----------------|--|-------------|------------------|
| X_G | Overall accuracy ¹⁾ @ I_{PN} , $T_A = 25^\circ\text{C}$ | $< \pm 0.6$ | % |
| ε_L | Linearity error | < 0.1 | % |
| | | Max | |
| I_O | Offset current @ $I_p = 0$, $T_A = 25^\circ\text{C}$ | ± 0.5 | mA |
| I_{OT} | Temperature variation of I_O - $40^\circ\text{C} \dots + 85^\circ\text{C}$ | ± 0.8 | mA |
| t_r | Response time ²⁾ to 90 % of I_{PN} step | < 1 | μs |
| di/dt | di/dt accurately followed | > 100 | A/ μs |
| BW | Frequency bandwidth (- 1 dB) | DC .. 100 | kHz |

General data

| | | | |
|-------|--|----------------|------------------|
| T_A | Ambient operating temperature | - 40 .. + 85 | $^\circ\text{C}$ |
| T_S | Ambient storage temperature | - 50 .. + 90 | $^\circ\text{C}$ |
| R_S | Secondary coil resistance @ $T_A = 85^\circ\text{C}$ | 47 | Ω |
| m | Mass | 400 | g |
| | Standard | EN 50155: 2001 | |

Notes: ¹⁾ The overall accuracy is $\pm 2.1\%$, at ambient temperature - 50°C , including a maximum offset drift 1.6 mA

²⁾ With a di/dt of 100 A/ μs .

Features

- Closed loop (compensated) current transducer using the Hall effect
- Isolated plastic case recognized according to UL 94-V0.

Special features

- Connection to secondary circuit on Burndy 6 poles SMS6GE6 connector
- N° DTR0000088987.

Advantages

- Excellent accuracy
- Very good linearity
- Low temperature drift
- Optimized response time
- Wide frequency bandwidth
- No insertion losses
- High immunity to external interference
- Current overload capability.

Applications

- Single or three phase inverter
- Propulsion and braking chopper
- Propulsion converter
- Auxiliary converter
- Battery charger.

Application Domain

- Traction.

Current Transducer LTC 500-SFC/SP2

Isolation characteristics

| | | | |
|----------------------|--|-------------------|----|
| V_d | Rms voltage for AC insulation test, 50 Hz, 1 min | 12 ¹⁾ | kV |
| | | 1.5 ²⁾ | kV |
| V_e | Partial discharge extinction voltage rms @ 10 pC | Min | |
| dCp | Creepage distance | 2.8 ³⁾ | kV |
| dCI | Clearance | 63.20 | mm |
| CTI | Comparative Tracking Index (group I) | 48.80 | mm |
| | | 600 | |

Notes: ¹⁾ Between primary and secondary + shield

²⁾ Between secondary and shield

³⁾ Test carried out with a busbar Ø 25 mm centered in the through hole.

Safety



This transducer must be used in electric/electronic equipment with respect to applicable standards and safety requirements in accordance with the manufacturer's operating instructions.



Caution, risk of electrical shock

When operating the transducer, certain parts of the module can carry hazardous voltage (eg. primary busbar, power supply).

Ignoring this warning can lead to injury and/or cause serious damage.

This transducer is a build-in device, whose conducting parts must be inaccessible after installation.

A protective housing or additional shield could be used.

Main supply must be able to be disconnected.

Dimensions LTC 500-SFC/SP2 (in mm)

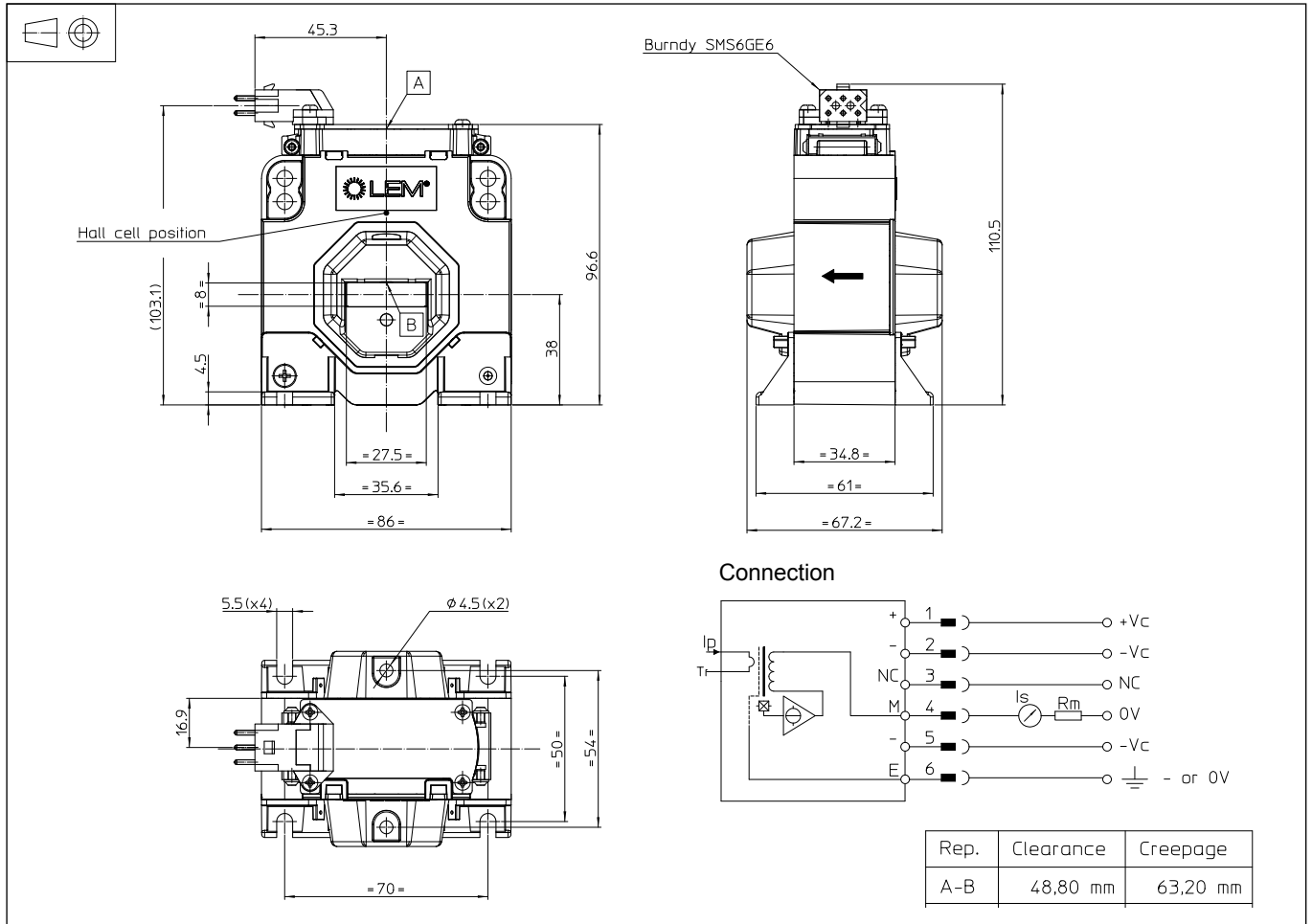

Mechanical characteristics

- General tolerance ± 1 mm
- Transducer fastening 4 slots $\varnothing 5.5$ mm
4 M5 steel screws
Recommended fastening torque 2.2 Nm
- Primary through-hole 27.5 x 8 mm
- Connection of secondary Burndy SMS6GE6

Remarks

- I_s is positive when I_p flows in the direction of the arrow.
- Temperature of the primary conductor should not exceed 100°C.
- Dynamic performances (di/dt and response time) are best with a single bar completely filling the primary hole.