

Voltage Transducer LV 100-1500/SP3

For the electronic measurement of voltages: DC, AC, pulsed..., with galvanic isolation between the primary circuit and the secondary circuit.

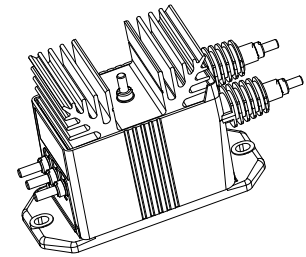

$$V_{PN} = 1500 \text{ V}$$



Electrical data

V_{PN}	Primary nominal voltage rms	1500	V			
V_{PM}	Primary current, measuring range	0 .. ± 2400	V			
I_{PN}	Primary nominal current rms	6.66	mA			
R_M	Measuring resistance	with $\pm 15 \text{ V}$	@ $\pm 1500 \text{ V}_{\text{max}}$	$R_{M \text{ min}}$ 0	$R_{M \text{ max}}$ 210	Ω
			@ $\pm 2400 \text{ V}_{\text{max}}$	0	110	Ω
		with $\pm 24 \text{ V}$	@ $\pm 1500 \text{ V}_{\text{max}}$	0	410	Ω
			@ $\pm 2400 \text{ V}_{\text{max}}$	110	230	Ω
I_{SN}	Secondary nominal current rms	50	mA			
K_N	Conversion ratio	1500 V : 50 mA				
V_C	Supply voltage ($\pm 5 \%$)	$\pm 15 \dots 24$	V			
I_C	Current consumption	$< 37 \text{ (@ } \pm 24 \text{ V)} + I_S$	mA			

Accuracy - Dynamic performance data

X_G	Overall accuracy @ V_{PN} , $T_A = 25^\circ\text{C}$	± 0.9	%
ε_L	Linearity error	< 0.1	%
I_O	Offset current @ $I_P = 0$, $T_A = 25^\circ\text{C}$	Typ ± 0.2	mA
I_{OT}	Temperature variation of I_O - $40^\circ\text{C} \dots + 85^\circ\text{C}$	Max ± 0.8	mA
t_r	Response time to 90 % of V_{PN} step	120	μs

General data

T_A	Ambient operating temperature	- 40 .. + 85	$^\circ\text{C}$
T_S	Ambient storage temperature	- 50 .. + 100	$^\circ\text{C}$
N_P	Turns ratio	15000 : 2000	
P	Total primary power loss	10	W
R_1	Primary resistance @ $T_A = 25^\circ\text{C}$	225	$\text{k}\Omega$
R_S	Secondary coil resistance @ $T_A = 85^\circ\text{C}$	65	Ω
m	Mass	870	g
	Standards	EN 50155: 1995	

Features

- Closed loop (compensated) voltage transducer using the Hall effect
- Isolated plastic case recognized according to UL 94-V0
- Primary resistor R_1 incorporated into the housing.

Special features

- $V_{PM} = 0 \dots \pm 2400 \text{ V}$
- $V_C = \pm 15 \dots 24 (\pm 5 \%) \text{ V}$
- $T_A = -40 \dots + 85 \text{ }^\circ\text{C}$
- Connection to secondary circuit on M5 threaded studs.

Advantages

- Excellent accuracy
- Very good linearity
- Low temperature drift
- High immunity to external interference.

Applications

- Single or three phase inverter
- Propulsion and braking chopper
- Propulsion converter
- Auxiliary converter
- Battery charger.

Application Domain

- Traction.

Current Transducer LV 100-1500/SP3

Isolation characteristics

V_d	Rms voltage for AC insulation test, 50 Hz, 1 min	6	kV
		Min	
dCp	Creepage distance	164.8	mm
dCl	Clearance distance	47.1	mm
CTI	Comparative Tracking Index (group I)	600	

Safety



This transducer must be used in electric/electronic equipment with respect to applicable standards and safety requirements in accordance with the manufacturer's operating instructions.



Caution, risk of electrical shock

When operating the transducer, certain parts of the module can carry hazardous voltage (eg. primary busbar, power supply).

Ignoring this warning can lead to injury and/or cause serious damage.

This transducer is a build-in device, whose conducting parts must be inaccessible after installation.

A protective housing or additional shield could be used.

Main supply must be able to be disconnected.

Dimensions LV 100-1500/SP3 (in mm)

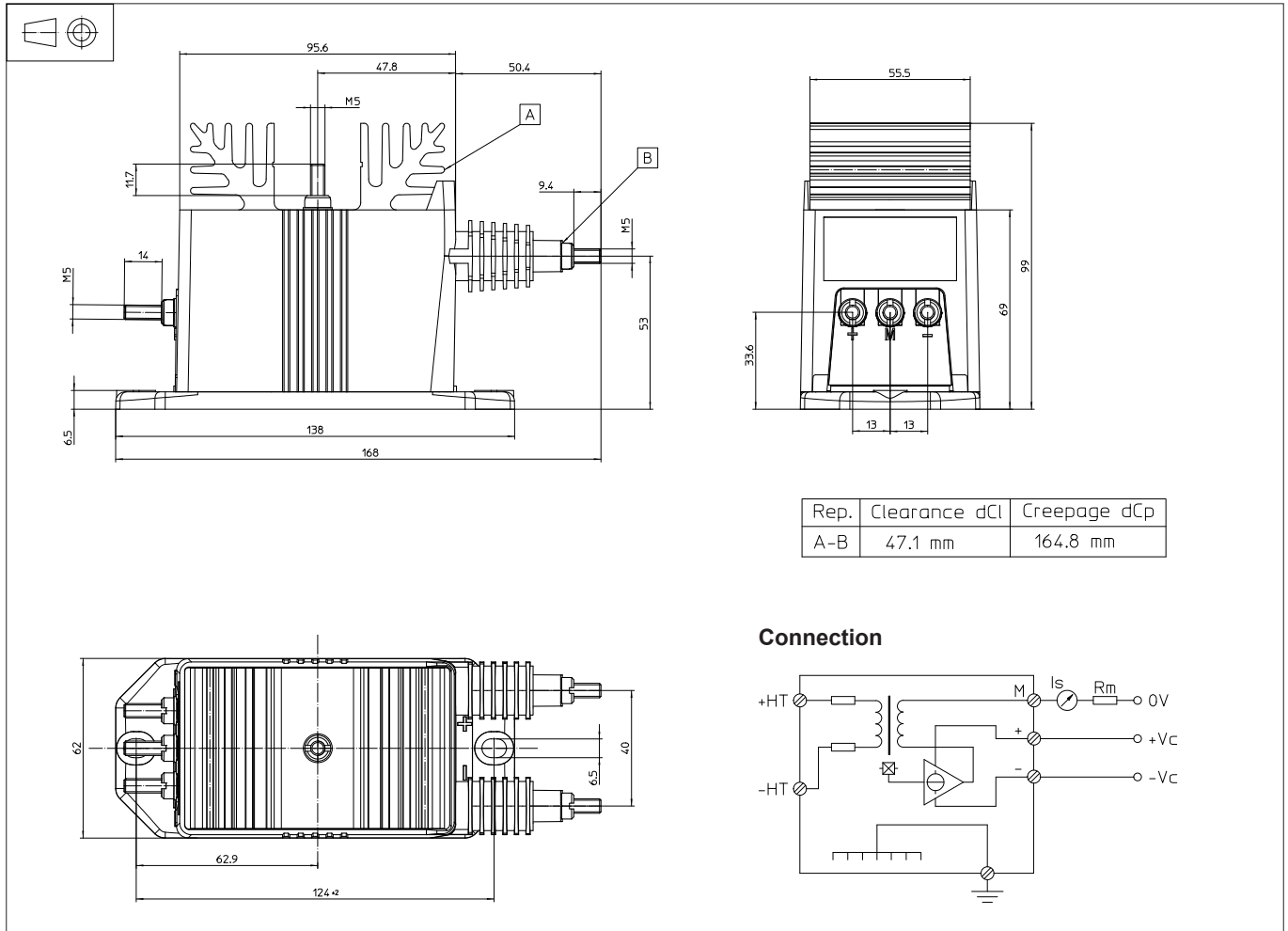

Mechanical characteristics

- General tolerance ± 0.3 mm
- Transducer fastening
 - 2 holes $\varnothing 6.5$ mm
 - M6 steel screws
- Recommended fastening torque 5 Nm
- Connection of primary M5 threaded studs
- Connection of secondary M5 threaded studs
- Connection to the ground M5 threaded stud
- Recommended fastening torque 2.2 Nm

Remarks

- I_s is positive when V_p is applied on terminal +HT.
- The primary circuit of the transducer must be linked to the connections where the voltage has to be measured.