

## Voltage Transducer LV 100-3000/SP12

For the electronic measurement of voltages: DC, AC, pulsed..., with galvanic isolation between the primary circuit (high power) and the secondary circuit (electronic circuit).

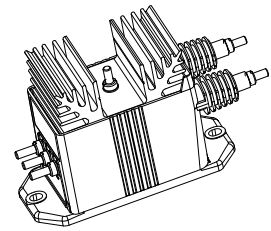

$$V_{PN} = 3000 \text{ V}$$



### Electrical data

$V_{PN}$	Primary nominal voltage rms	3000	V			
$V_{PM}$	Primary voltage, measuring range	0 .. $\pm 5000$	V			
$I_{PN}$	Primary nominal current rms	3.33	mA			
$R_M$	Measuring resistance	$R_{M \min}$	$R_{M \max}$			
					with $\pm 15 \text{ V}$	@ $\pm 3000 \text{ V}_{\max}$
			@ $\pm 5000 \text{ V}_{\max}$	0	102	$\Omega$
		with $\pm 24 \text{ V}$	@ $\pm 3000 \text{ V}_{\max}$	100	360	$\Omega$
			@ $\pm 5000 \text{ V}_{\max}$	100	190	$\Omega$
$I_{SN}$	Secondary nominal current rms	50	mA			
$K_N$	Conversion ratio	3000 V : 50 mA				
$V_C$	Supply voltage ( $\pm 5 \%$ )	$\pm 15 \dots 24$	V			
$I_C$	Current consumption	$< 37$ (@ $\pm 24 \text{ V}$ ) + $I_S$	mA			

### Accuracy - Dynamic performance data

$X_G$	Overall accuracy @ $V_{PN}$ , $T_A = 25^\circ\text{C}$	$\pm 0.9$	%
$\mathcal{E}_L$	Linearity error	$< 0.1$	%
$I_O$	Offset current @ $I_P = 0$ , $T_A = 25^\circ\text{C}$	Typ	Max
$I_{OT}$	Temperature variation of $I_O$	- $25^\circ\text{C} \dots + 70^\circ\text{C}$	$\pm 0.3$   $\pm 0.6$ mA
		- $40^\circ\text{C} \dots + 70^\circ\text{C}$	$\pm 0.4$   $\pm 0.8$ mA
		- $40^\circ\text{C} \dots + 85^\circ\text{C}$	$\pm 0.4$   $\pm 0.8$ mA
$t_r$	Response time to 90 % of $V_{PN}$ step	70	$\mu\text{s}$

### General data

$T_A$	Ambient operating temperature	- 40 .. + 85	$^\circ\text{C}$
$T_S$	Ambient storage temperature	- 40 .. + 85	$^\circ\text{C}$
$N_P$	Turns ratio	30000 : 2000	
$P$	Total primary power loss	10	W
$R_1$	Primary resistance @ $T_A = 25^\circ\text{C}$	900	k $\Omega$
$R_S$	Secondary coil resistance	@ $T_A = 70^\circ\text{C}$	55 $\Omega$
		@ $T_A = 85^\circ\text{C}$	57 $\Omega$
$m$	Mass	790	g
	Standards	EN 50155: 1995	

### Features

- Closed loop (compensated) voltage transducer using the Hall effect
- Isolated plastic case recognized according to UL 94-V0
- Primary resistor  $R_1$  incorporated into the housing.

### Special features

- $V_C = \pm 15 \dots 24$  ( $\pm 5 \%$ ) V
- $V_d = 12 \text{ kV}$
- $T_A = - 40^\circ\text{C} \dots + 85^\circ\text{C}$
- Connection to secondary circuit on M5 threaded studs
- Personalized label.

### Advantages

- Excellent accuracy
- Very good linearity
- Low temperature drift
- Optimized response time
- Wide frequency bandwidth
- No insertion losses
- High immunity to external interference.

### Applications

- Single or three phase inverter
- Propulsion and braking chopper
- Propulsion converter
- Auxiliary converter
- Battery charger.

### Application Domain

- Traction.

## Voltage Transducer LV 100-3000/SP12

### Isolation characteristic

<b>V<sub>d</sub></b>	Rms voltage for AC isolation test, 50 Hz, 1 min	12 Min	kV
<b>dCp</b>	Creepage distance	164.8	mm
<b>dCl</b>	Clearance distance	47.1	mm
<b>CTI</b>	Comparative Tracking Index (group I)	600	

### Safety



This transducer must be used in electric/electronic equipment with respect to applicable standards and safety requirements in accordance with the manufacturer's operating instructions.



Caution, risk of electrical shock

When operating the transducer, certain parts of the module can carry hazardous voltage (eg. primary busbar, power supply).

Ignoring this warning can lead to injury and/or cause serious damage.

This transducer is a build-in device, whose conducting parts must be inaccessible after installation.

A protective housing or additional shield could be used.

Main supply must be able to be disconnected.

## Dimensions LV 100-3000/SP12 (in mm)

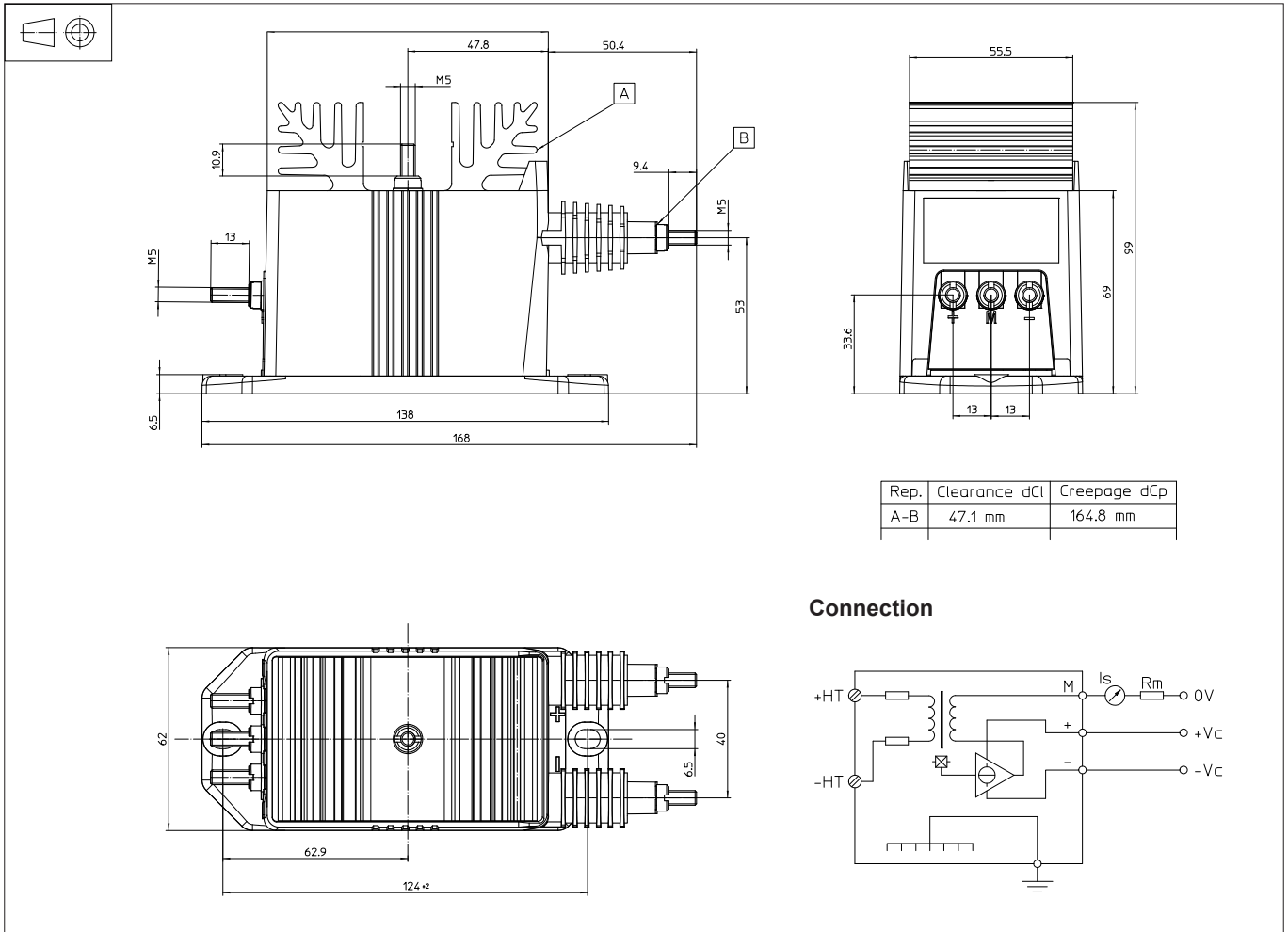

### Mechanical characteristics

- General tolerance  $\pm 0.3$  mm
- Transducer fastening  
2 holes  $\varnothing 6.5$  mm,  
2 M6 steel screws  
Recommended fastening torque 5 Nm
- Connection of primary M5 threaded studs
- Connection of secondary M5 threaded studs
- Connection of ground M5 threaded studs  
Recommended fastening torque 2.2 Nm

### Remarks

- $I_s$  is positive when  $V_p$  is applied on terminal +HT.
- The primary circuit of the transducer must be linked to the connections where the voltage has to be measured.