

# Voltage Transducer LV 100-3000/SP13

$V_{PN} = 2800 \text{ V}$

For the electronic measurement of voltages : DC, AC, pulsed..., with a galvanic isolation between the primary circuit (high voltage) and the secondary circuit (electronic circuit).



## Electrical data

$V_{PN}$	Primary nominal r.m.s. voltage	2800	V			
$V_P$	Primary voltage, measuring range	0 .. $\pm 4500$	V			
$I_{PN}$	Primary nominal r.m.s. current	2.8	mA			
$R_M$	Measuring resistance	$R_{M \min}$	$R_{M \max}$			
				with $\pm 15 \text{ V}$	@ $\pm 2800 \text{ V}_{\max}$	0
			@ $\pm 4500 \text{ V}_{\max}$	0	102	$\Omega$
		with $\pm 24 \text{ V}$	@ $\pm 2800 \text{ V}_{\max}$	50	350	$\Omega$
	@ $\pm 4500 \text{ V}_{\max}$	50	180	$\Omega$		
$I_{SN}$	Secondary nominal r.m.s. current	50	mA			
$K_N$	Conversion ratio	2800 V / 50 mA				
$V_C$	Supply voltage (+ 5/- 10 %)	$\pm 15 \dots 24$	V			
$I_C$	Current consumption	28 (@ $\pm 24 \text{ V}$ ) + $I_S$	mA			
$V_d$	R.m.s. voltage for AC isolation test, 50 Hz, 1 mn	12 <sup>1)</sup>	kV			
		1 <sup>2)</sup>	kV			

## Features

- Closed loop (compensated) voltage transducer using the Hall effect
- Insulated plastic case recognized according to UL 94-V0
- Primary resistor  $R_1$  incorporated within the housing.

## Special features

- $V_{PN} = 2800 \text{ V}$
- $V_C = \pm 15 \dots 24 (+ 5/- 10 \%) \text{ V}$
- $V_d = 12 \text{ kV}$  <sup>1)</sup>
- $T_A = -25^\circ\text{C} \dots +70^\circ\text{C}$
- Shield
- Connection to primary and secondary circuit on M5 threaded studs
- VRT Burn-in
- Railway equipment.

## Accuracy - Dynamic performance data

$X_G$	Overall Accuracy @ $V_{PN}, T_A = 25^\circ\text{C}$	$\pm 0.7$	%	
$e_L$	Linearity	< 0.1	%	
$I_O$	Offset current @ $I_P = 0, T_A = 25^\circ\text{C}$	Typ	Max	
			$\pm 0.3$	mA
$I_{OT}$	Thermal drift of $I_O$ - $25^\circ\text{C} \dots +70^\circ\text{C}$	$\pm 0.3$	$\pm 0.5$	mA
$t_t$	Response time @ 90 % of $V_{PN}$	180	$\mu\text{s}$	

## Advantages

- Excellent accuracy
- Very good linearity
- Low thermal drift
- High immunity to external interference.

## General data

$T_A$	Ambient operating temperature	- 25 .. + 70	$^\circ\text{C}$
$T_S$	Ambient storage temperature	- 45 .. + 85	$^\circ\text{C}$
$N$	Turns ratio	35000 : 2000	
$P$	Total primary power loss	7.84	W
$R_1$	Primary resistance @ $T_A = 25^\circ\text{C}$	1	M $\Omega$
$R_S$	Secondary coil resistance @ $T_A = 70^\circ\text{C}$	60	$\Omega$
$m$	Mass	850	g
	Standards	EN 50155	

## Applications

- AC variable speed drives and servo motor drives
- Static converters for DC motor drives
- Uninterruptible Power Supplies (UPS)
- Power supplies for welding applications
- Railway overhead line voltage measurement.

Notes : <sup>1)</sup> Between primary and secondary + shield

<sup>2)</sup> Between secondary and shield.

## Dimensions LV 100-3000/SP13 (in mm. 1 mm = 0.0394 inch)

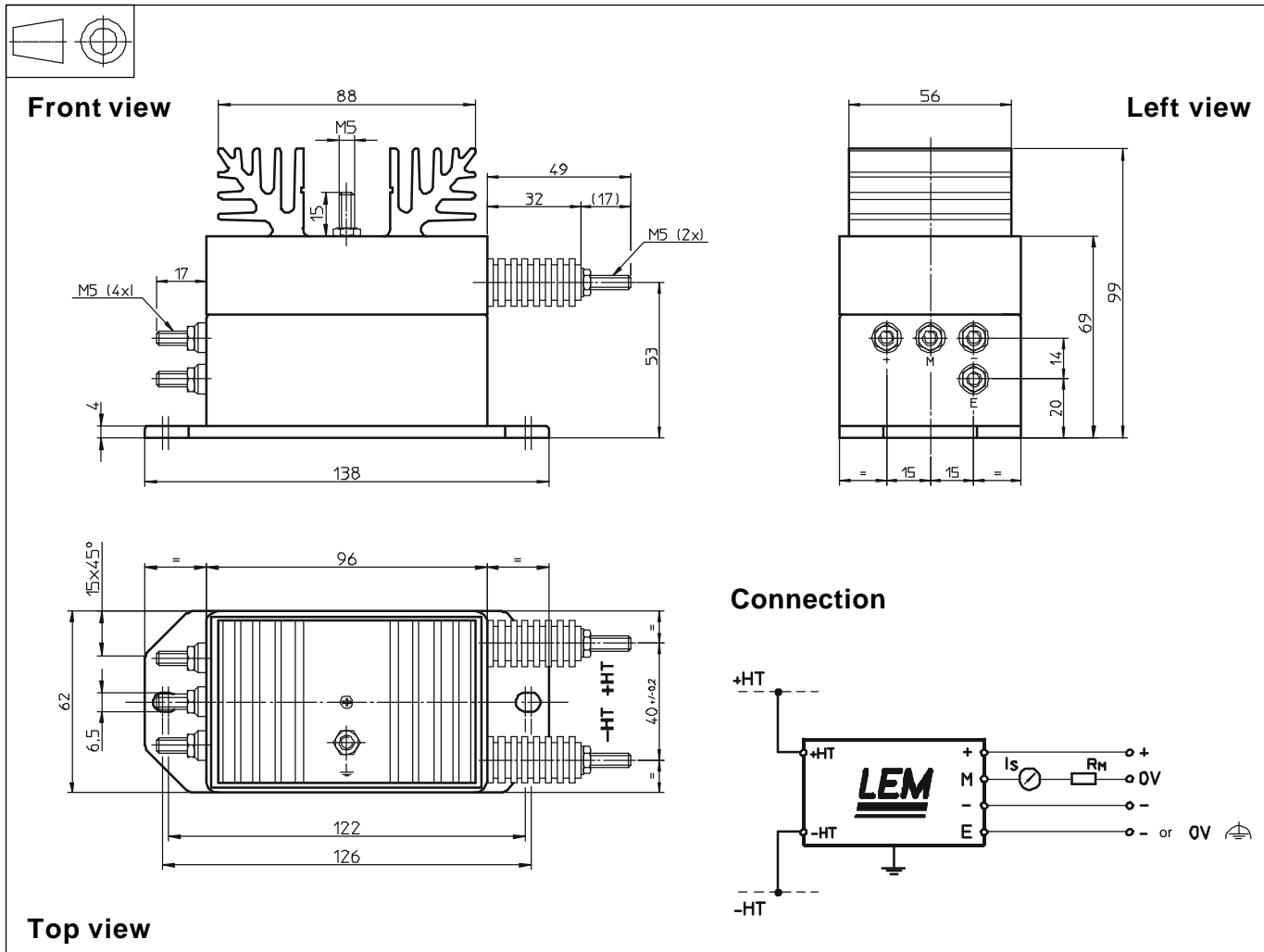

### Mechanical characteristics

- |                            |   |
|----------------------------|---|
| • General tolerance        | $\pm 0.3$ mm                                    |
| • Transducer fastening     | 2 holes $\varnothing 6.5$ mm<br>M6 steel screws |
| Fastening torque max       | 5 Nm or 3.69 Lb - Ft.                           |
| • Connection of primary    | M5 threaded studs                               |
| • Connection of secondary  | M5 threaded studs                               |
| • Connection to the ground | M5 threaded stud                                |
| • Fastening torque max     | 2.2 Nm or 1.62 Lb. - Ft.                        |

### Remarks

- $I_s$  is positive when  $V_p$  is applied on terminal +HT.
- The primary circuit of the transducer must be linked to the connections where the voltage has to be measured.