

Voltage Transducer LV 100-3500

For the electronic measurement of voltages: DC, AC, pulsed..., with galvanic isolation between the primary circuit and the secondary circuit.

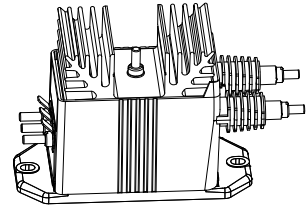

$$V_{PN} = 3500 \text{ V}$$



Electrical data

V_{PN}	Primary nominal voltage rms	3500	V
V_{PM}	Primary voltage, measuring range	0 .. ± 4500	V
I_{PN}	Primary nominal current rms	2.85	mA
R_M	Measuring resistance	$R_{M \min}$ $R_{M \max}$	
	with $\pm 15 \text{ V}$	@ $\pm 3000 \text{ V}_{\max}$	0 210 Ω
		@ $\pm 4500 \text{ V}_{\max}$	0 130 Ω
I_{SN}	Secondary nominal current rms	50	mA
K_N	Conversion ratio	3500 V : 50 mA	
V_C	Supply voltage ($\pm 5 \%$)	± 15	V
I_C	Current consumption	$< 32 + I_s$	mA

Accuracy - Dynamic performance data

X_G	Overall accuracy @ V_{PN} , $T_A = 25^\circ\text{C}$	± 0.9	%
ϵ_L	Linearity error	< 0.1	%
I_O	Offset current @ $I_p = 0$, $T_A = 25^\circ\text{C}$	Typ	± 0.2 mA
		Max	± 0.2 mA
I_{OT}	Temperature variation of I_O $0^\circ\text{C} \dots +70^\circ\text{C}$	± 0.2 ± 0.3	mA
t_r	Response time to 90 % of V_{PN} step	190	μs

General data

T_A	Ambient operating temperature	0 .. +70	$^\circ\text{C}$
T_S	Ambient storage temperature	-25 .. +85	$^\circ\text{C}$
N_P	Turns ratio	36000 : 2000	
P	Total primary power loss	10	W
R_1	Primary resistance @ $T_A = 25^\circ\text{C}$	1.225	$M\Omega$
R_S	Secondary coil resistance @ $T_A = 70^\circ\text{C}$	55	Ω
m	Mass	790	g
	Standards	EN 50178: 1997	

Features

- Closed loop (compensated) voltage transducer using Hall effect
- Isolated plastic case recognized according to UL 94-V0
- Primary resistor R_1 incorporated within the housing.

Advantages

- Excellent accuracy
- Very good linearity
- Low temperature drift
- Optimized response time
- Wide frequency bandwidth
- No insertion losses
- High immunity to external interference.

Applications

- AC variable speed drives and servo motor drives
- Static converters for DC motor drives
- Uninterruptible Power Supplies (UPS)
- Power supplies for welding applications.

Application domain

- Industrial.

Voltage Transducer LV 100-3500

Isolation characteristic

V_d	Rms voltage for AC isolation test, 50 Hz, 1 min	12	kV
\hat{V}_w	Impulse withstand voltage 1.2/50 μ s	31.3	kV
		Min	
dCp	Creepage distance	164.8	mm
dCI	Clearance	47.1	mm
CTI	Comparative Tracking Index (group I)	600	

Applications examples

According to EN 50178 and IEC 61010-1 standards and following conditions:

- Over voltage category OV 3
- Pollution degree PD2
- Non-uniform field

	EN 50178	IEC 61010-1
dCp, dCI, \hat{V}_w	Rated insulation voltage	Nominal voltage
Single insulation	3500 V	1000 V
Reinforced insulation	3500 V	1000 V

Safety



This transducer must be used in electric/electronic equipment with respect to applicable standards and safety requirements in accordance with the manufacturer's operating instructions.



Caution, risk of electrical shock

When operating the transducer, certain parts of the module can carry hazardous voltage (eg. primary busbar, power supply).

Ignoring this warning can lead to injury and/or cause serious damage.

This transducer is a build-in device, whose conducting parts must be inaccessible after installation.

A protective housing or additional shield could be used.

Main supply must be able to be disconnected.

Dimensions LV 100-3500 (in mm)

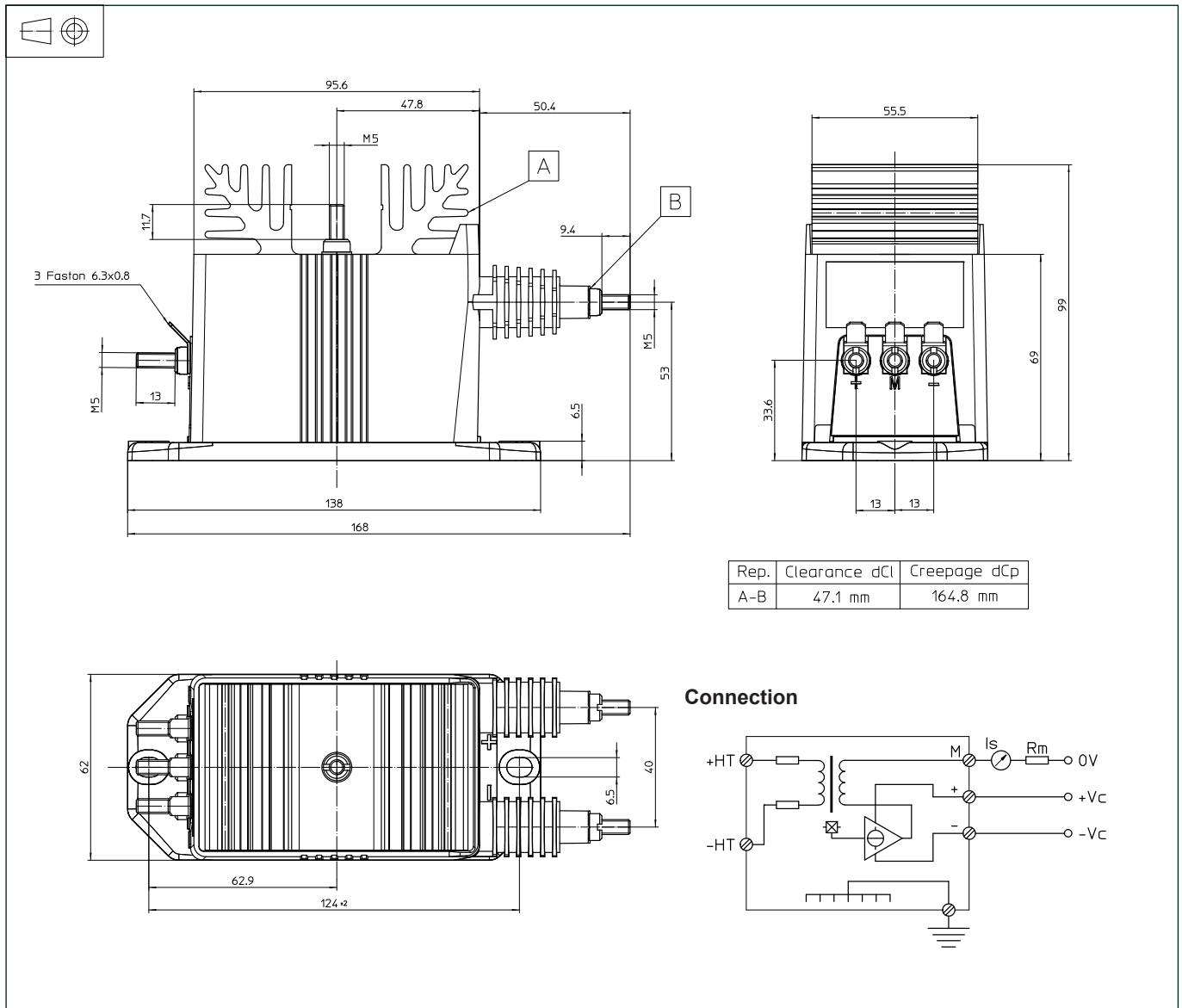

Mechanical characteristics

- General tolerance ± 0.3 mm
- Transducer fastening 2 holes $\varnothing 6.5$ mm,
2 M6 steel screws
Recommended fastening torque 5 Nm
- Connection of primary M5 threaded studs
- Connection of secondary Faston 6.3 x 0.8 mm
- Connection of ground M5 threaded stud
Recommended fastening torque 2.2 Nm

Remarks

- I_s is positive when V_p is applied on terminal +HT.
- The primary circuit of the transducer must be linked to the connections where the voltage has to be measured.
- This is a standard model. For different versions (supply voltages, turns ratios, unidirectional measurements...), please contact us.