

## Voltage Transducer LV 100-750/SP4

For the electronic measurement of voltages: DC, AC, pulsed..., with galvanic isolation between the primary circuit and the secondary circuit.

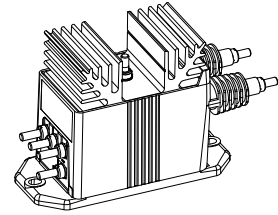

$$V_{PN} = 750 \text{ V}$$



### Electrical data

$V_{PN}$	Primary nominal voltage rms	750	V			
$V_{PM}$	Primary voltage, measuring range	0 .. $\pm 1500$	V			
$I_{PN}$	Primary nominal current rms	13.33	mA			
$R_M$	Measuring resistance	$R_{M \min}$	$R_{M \max}$			
				with $\pm 15 \text{ V}$	@ $\pm 750 \text{ V}_{\max}$	0
			@ $\pm 1500 \text{ V}_{\max}$	0	70	$\Omega$
		with $\pm 24 \text{ V}$	@ $\pm 750 \text{ V}_{\max}$	0	410	$\Omega$
	@ $\pm 1500 \text{ V}_{\max}$	110	170	$\Omega$		
$I_{SN}$	Secondary nominal current rms	50	mA			
$K_N$	Conversion ratio	750 V : 50 mA				
$V_C$	Supply voltage ( $\pm 10 \%$ )	$\pm 15 \dots 24$	V			
$I_C$	Current consumption	$< 37$ (@ $\pm 24\text{V}$ ) + $I_S$	mA			

### Accuracy - Dynamic performance data

$X_G$	Overall accuracy <sup>1)</sup> @ $V_{PN}, T_A = 25^\circ\text{C}$	$\pm 0.9$	%
$\epsilon_L$	Linearity error	$< 0.1$	%
$I_O$	Offset current @ $I_p = 0, T_A = 25^\circ\text{C}$	Typ	$\pm 0.2$ mA
		Max	$\pm 0.6$ mA
$I_{OT}$	Temperature variation of $I_O$ - $25^\circ\text{C} \dots +70^\circ\text{C}$		$\pm 0.4$ mA
		- $40^\circ\text{C} \dots +70^\circ\text{C}$	$\pm 0.6$ mA
$t_r$	Response time <sup>2)</sup> to 90 % of $V_{PN}$ step	90	$\mu\text{s}$

### General data

$T_A$	Ambient operating temperature	- 40 .. + 70	$^\circ\text{C}$
$T_S$	Ambient storage temperature	- 50 .. + 85	$^\circ\text{C}$
$N_P$	Turns ratio	7500 : 2000	
$P$	Total primary power loss	10	W
$R_1$	Primary resistance @ $T_A = 25^\circ\text{C}$	56.25	k $\Omega$
$R_S$	Secondary coil resistance @ $T_A = 70^\circ\text{C}$	55	$\Omega$
$m$	Mass	790	g
	Standards	EN 50155: 1995	

**Notes:** <sup>1)</sup> The overall accuracy is  $\pm 6 \%$  at ambient temperature  $-50^\circ\text{C}$ , including a maximum offset drift 2.2 mA

<sup>2)</sup> With a di/dt of 100 A/ $\mu\text{s}$ .

### Features

- Closed loop (compensated) voltage transducer using Hall effect
- Isolated plastic case recognized according to UL 94-V0
- Primary resistor  $R_1$  incorporated within the housing.

### Special features

- $V_C = \pm 15 \dots 24$  ( $\pm 10 \%$ ) V
- $T_A = -40^\circ\text{C} \dots +70^\circ\text{C}$
- Shield between primary and secondary
- Without electrolytic capacitors
- Error caused by a magnetic field of 2 mT at 20 mm:  $< 1 \%$  of  $V_{PN}$
- Connection primary and secondary circuit on M5 threaded studs.

### Advantages

- Excellent accuracy
- Very good linearity
- Low temperature drift
- Optimized response time
- Wide frequency bandwidth
- No insertion losses
- High immunity to external interference.

### Applications

- Single or three phase inverter
- Propulsion and braking chopper
- Propulsion converter
- Auxiliary converter
- Battery charger.

### Application Domain

- Traction.

## Voltage Transducer LV 100-750/SP4

### Isolation characteristics

<b>V<sub>d</sub></b>	Rms voltage for AC isolation test, 50 Hz, 1 min	6 <sup>1)</sup>	kV
		1 <sup>2)</sup>	kV
		Min	
<b>dCp</b>	Creepage distance	164.8	mm
<b>dCI</b>	Clearance	47.1	mm
<b>CTI</b>	Comparative Tracking Index (group I)	600	

**Notes:** <sup>1)</sup> Between primary and secondary + shield

<sup>2)</sup> Between secondary and shield.

### Safety



This transducer must be used in electric/electronic equipment with respect to applicable standards and safety requirements in accordance with the manufacturer's operating instructions.



Caution, risk of electrical shock

When operating the transducer, certain parts of the module can carry hazardous voltage (eg. primary busbar, power supply).

Ignoring this warning can lead to injury and/or cause serious damage.

This transducer is a build-in device, whose conducting parts must be inaccessible after installation.

A protective housing or additional shield could be used.

Main supply must be able to be disconnected.

## Dimensions LV 100-750/SP4 (in mm)

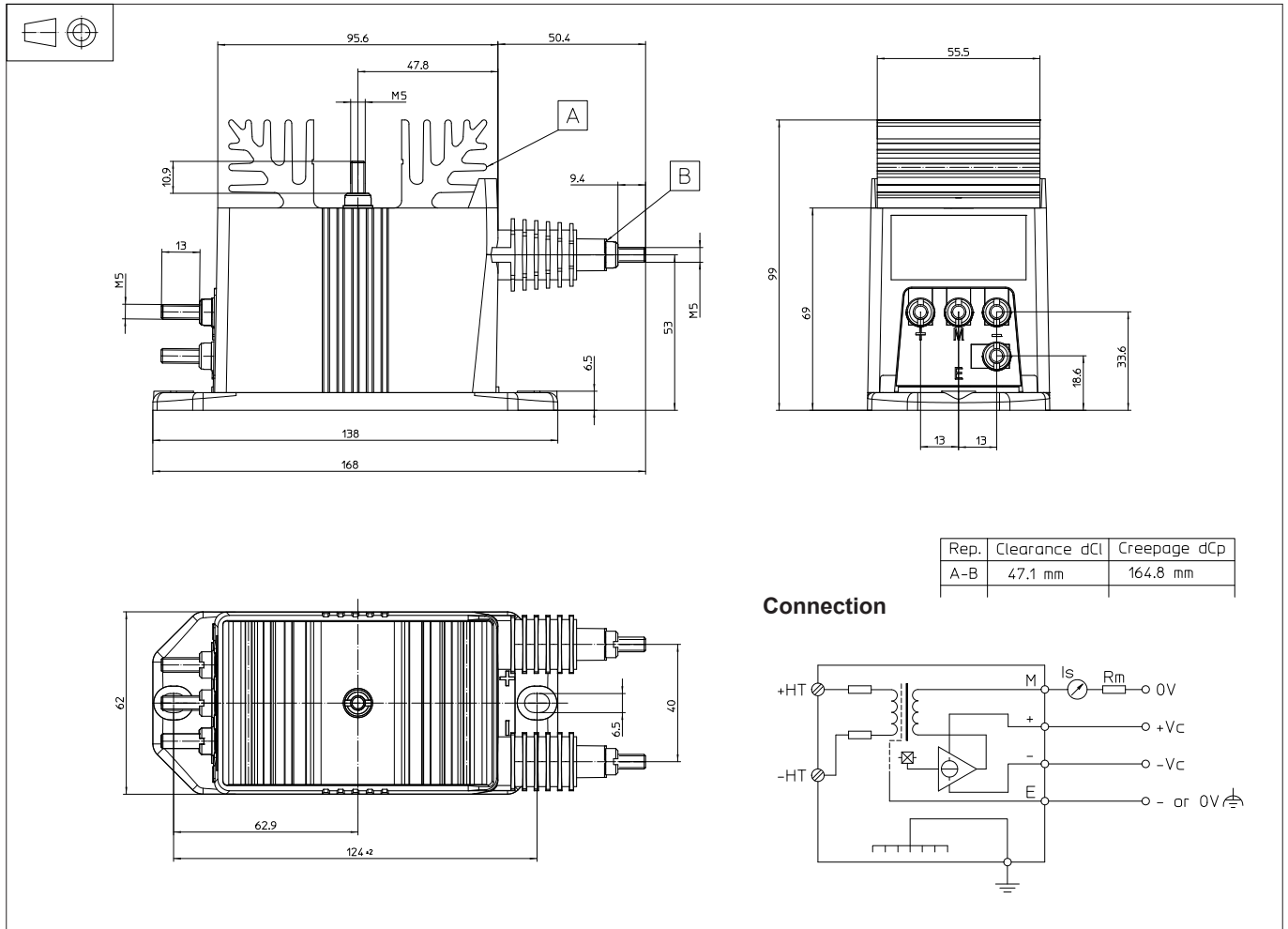

### Mechanical characteristics

- General tolerance  $\pm 0.3$  mm
- Transducer fastening 2 holes  $\varnothing 6.5$  mm,  
2 M6 steel screws
- Recommended fastening torque 5 Nm
- Connection of primary M5 threaded studs
- Connection of secondary M5 threaded studs
- Connection of ground M5 threaded stud
- Recommended fastening torque 2.2 Nm

### Remarks

- $I_s$  is positive when  $V_p$  is applied on terminal +HT.
- The primary circuit of the transducer must be linked to the connections where the voltage has to be measured.