



## Control the speed and protect EMUs propulsion inverters

### Applications

#### Control and protection in the traction drive system

- Control the input current & the EMU speed
- Control & protect the inverter
- Protect the power semiconductors in the inverter

### Features

- Bipolar AC & DC current measurement of 500 & 1000 Arms nominal
- Design versatility
- Multitude of mounting options
- Bipolar +/- 15 to 24 Volts power supply
- Current output signal
- Galvanic Isolation : 13.4kVrms/50Hz/1 min
- EN 50155, EN 50124-1 (insulation levels), NFF 16101/2 fire and smoke classification Compliance
- CE Marking
- 5 years warranty

EMUs use current measurement in traction drive systems to control their speed and to protect the electronic systems. These applications require compact and modular transducers to fit into the existing, confined locations

Electrical Multiple Units (EMU) and Passenger Multiple Units use a traction inverter system to convert the power from the supply point (Catenary, 3<sup>rd</sup> Rail or Generator), to the propulsion motor. At different locations in the drive, current measurement is used to control the speed and protect the EMU.

For these functions, space is at a premium. The space available limits the number of fixing options that can be included in any one transducer type. The answer is a modular design where the customer can specify the mounting options. The new LTC 600 and 1000 models have been optimized to solve this problem with a modern, easy to use, modular design. Although versatility is important, we must remember that these devices will be used in ap-

plications with significant external influences from adjacent conductors which can cause erroneous outputs and possible damage the transducer. LEM have designed the internal electronics of the LTC 600 and LTC 1000 transducers to allow rotation of the PCB during manufacturing. This rotation enables the user to create the maximum distance between the Hall Sensing Element and the source of interference. The LTC 600 and LTC 1000 cover the nominal measuring range of 500 A and 1000 Arms across the operating temperature range from -40°C to +85°C. The devices have peak measuring ranges significantly higher than these figures which make them ideal for propulsion inverter applications that have high start up and dynamic braking currents.

In such applications high dv/dt's are present which can cause capacitive coupling between the primary conductor and the secondary winding in the transducer, to overcome this, all standard types are fitted with a shield which the user can connect to an appropriate point in his system.

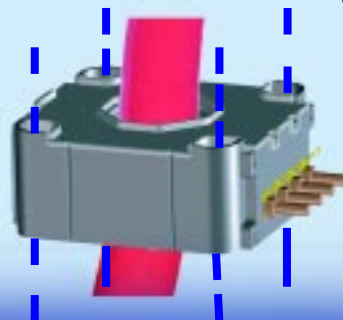

MODULAR AC/DC CURRENT TRANSDUCERS : *LTC Series*



[www.lem.com](http://www.lem.com)

# Application Note

## Control & protection in the traction drive

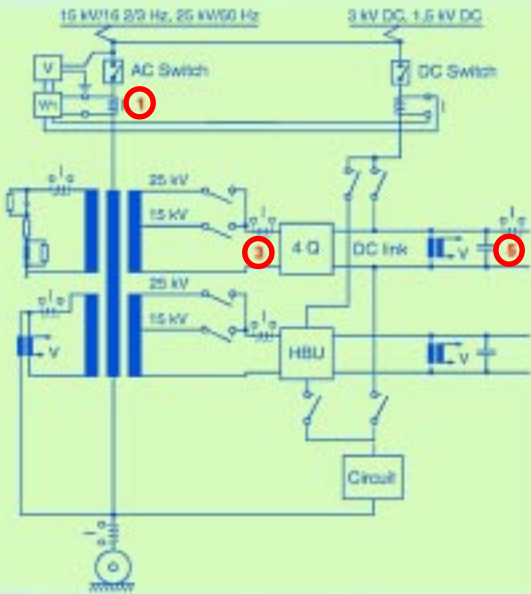

- In the traction drive system, protection and control are implemented by measuring the current in up to 5 locations :
- Location ① Measures the input current.
  - Location ② Measures the motor currents as part of the EMU speed control system.
  - Location ③ Protects the four quadrant controller by measuring the input current.
  - Location ④ Protection of the power semiconductors by direct current measurement
  - Location ⑤ Detection of DC link current and polarity to protect the power semiconductors.

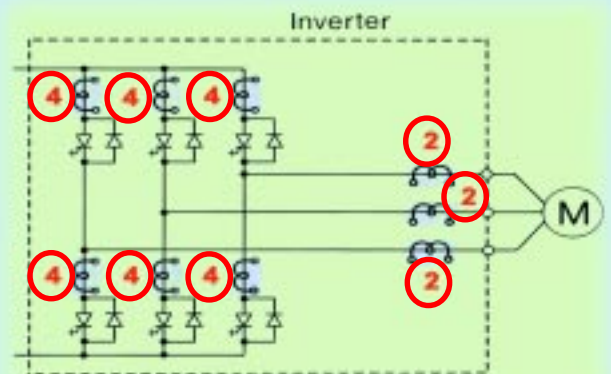
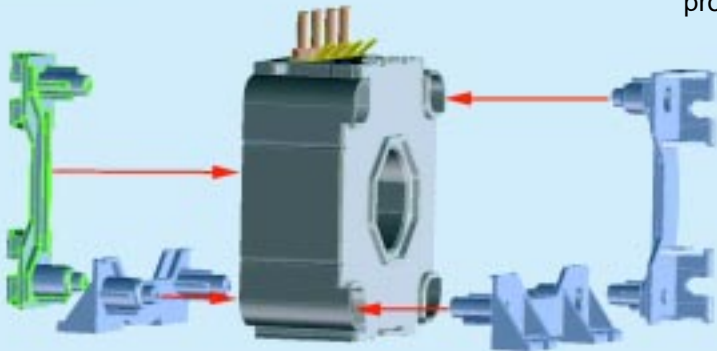

The development of this new range of LTC 600 and 1000 transducers covers all these applications in a compact yet user friendly package. The design modularity allows the devices to be fitted in a flat position or when the adaptable feet are offered, they can be vertically in one of 3 positions. To this is added the option of a through hole aperture for cables or the ability to fit a bus bar during the manufacturing or later by the user.

The standard product is fitted with both M5 threaded studs and 6.3mm Faston connections to reduce the customers inventory for both new projects and spares support. For customers that prefer cable or connector outputs, these can be easily added during the manufacturing process.

This type of modularity allows LEM to offer more than 180 options in the product whilst still maintaining value for money for the customer.

The LTC 600 is both mechanically and electrically compatible with the successful LT 505 range and can be used to replace it either for spares or new designs whilst the LTC 1000 offers the same upgrade path for the LT 1005 family of products.



**MODULAR AC/DC CURRENT TRANSDUCERS : *LTC Series***