

*Improve the
performance
of Existing
Installations*

Modernise Your Manufacturing With Smart Modifications

Applications

- **Automation systems**
Analog current reading for remote monitoring (e.g. motor) and software alarms.
- **Data loggers**
Self-powered transducer does not drain data logger batteries.
- **Panel meters**
Simple connection displays power consumption.

Features

- *AC and DC current measurement*
- *Calculation of RMS value for AC signals*
- *Current or voltage output signals*
- *Self powered for voltage outputs*
- *Loop powered for 4-20mA outputs*
- *Isolation up to 5kV*
- *Jumper selectable ranges*
- *Panel and DIN mounting*

Improving total manufacturing efficiency and effectiveness is a principal method improve reliability and increase productivity. Modern installations need an efficient interface between several mediums. Solutions exists for your new installations, but what about your existing installations ?

In industrial fields, several methods are used to ensure the function of any industrial process, a mix of electrical, hydraulic and mechanical systems. The combination could be between old and modern installations and to have a good operation, it is necessary to have a good interface between several sub-systems.

To convert your systems into modern efficient processes that satisfy relevant safety standards. These modifications often require production to stop and therefore increase costs. Replacement of traditional sensors (pressure, torque etc..) with current measurement devices is more commonplace in industrial applications to ensure the protection, regulation and monitoring of processes. Furthermore, current measurement facilitates accurate, fast, economic and easy data acquisition. To modernize your systems without redesign, re-cabling,

reconnection, LEM proposes its new product range of current transducers which integrate easily in your process without any modification.

The clamp on design allows installation of the transducer around the cable without cutting or disconnecting.

LEM Current transducers allows measurement of AC or DC currents and outputs are a DC signal adapted to standard industrial interfaces. In fact, the output signal can be in current or in voltage (0-5V, 0-10V or 4-20mA) to satisfy application requirements.

For AC current, transducers calculate the true RMS value. Thus, you have not to add an AC/DC converter to measure or analyse your signal.

An isolation is ensured between power and electronic circuits. For ease of installation, products are adapted for panel or DIN mounting.

CURRENT TRANSDUCERS: *AP-, APR-, AK-B, AKR-B* and *DK-B* Series

LEM
www.lem.com

Application Note



Pump Backup

Critical loads require a backup pump that starts automatically in the case of a failure. Installing a current transducer on the power lead of each pump gives you real-time on/off status. The analog outputs can be wired into a PLC to automate the backup routines.

Knowledge of pump status allows programming maintenance schedule and to optimise the repairing operation.

Available transducers provide a RMS value of measuring current and ensure fast, reliable response to pump failure.

The clamp on design allows the transducers to be installed in existing installations without the need stop the machines working.

Crusher and Grinder Motors

You can optimise the performance of your size reduction equipment by automating the feed mechanism. Controlling the feed rate to grinders, crushers and shredders

- helps prevent jamming
- improves the uniformity or structure of ground product
- enhances the efficiency of subsequent processing operations

For a precise indication of the load on the crusher, simply install a current transducer on the motor lead. The output can be used for reliable closed-loop control between the crusher and the feeding mechanism. A drop in load will signal the conveyor or loader to increase the feed rate. A rise in load will indicate a decrease in the feed rate.

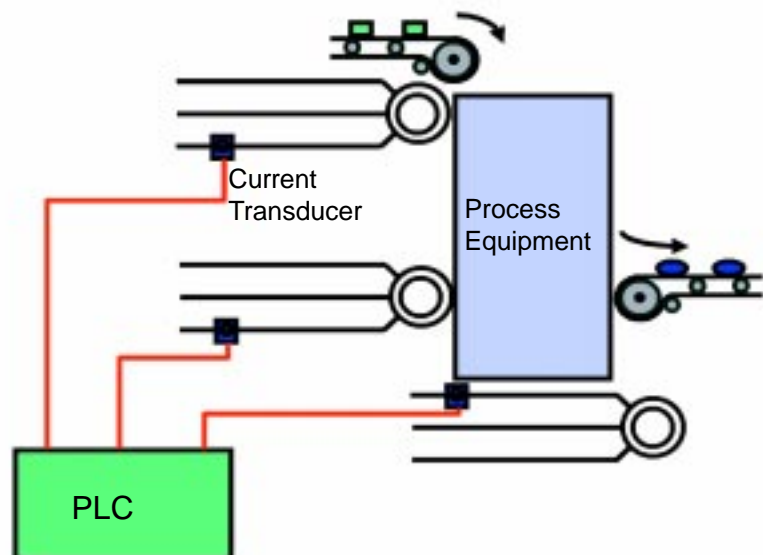

CURRENT TRANSDUCERS: *AP-*, *APR-*, *AK-B*, *AKR-B* and *DK-B* Series

