

## Current Transducer HMSR-SMS series

$I_{PN} = 6 \dots 30 \text{ A}$

Ref: HMSR 6-SMS, HMSR 8-SMS, HMSR 10-SMS, HMSR 20-SMS,  
HMSR 30-SMS

For the electronic measurement of current: DC, AC, pulsed..., with galvanic separation between the primary and the secondary circuit.

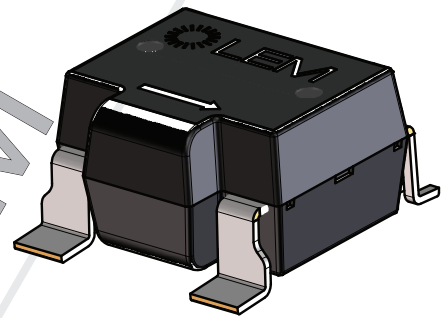

### Features

- Open loop multi-range current transducer
- Voltage output
- Double overcurrent detection
- Single power supply +5 V
- 3.3 V SP version available
- Galvanic separation between primary and secondary
- Low power consumption
- Compact design for surface mount PCB mounting
- Factory calibrated
- High bandwidth, very low loss magnetic core.

### Advantages

- Low profile:  $h = 6 \text{ mm}$
- Low foot-print
- Low electrical resistance  $0.76 \text{ m}\Omega$
- Reinforced insulation capability.
- High resolution
- High immunity to external interference.

### Applications

- Small drives
- HVAC
- Appliances
- Solar.

### Standards

- IEC 61800-5-1: 2007
- IEC 62109-1: 2010
- IEC 60950-1: 2005.

### Application Domain

- Industrial.

**Insulation coordination**

Parameter	Symbol	Unit	Value	Comment
RMS voltage for AC insulation test, 50/60 Hz, 1 min	$U_d$	kV	4.95	According to IEC 60950-1
Impulse withstand voltage 1.2/50 $\mu$ s	$\hat{U}_w$	kV	8	
Partial discharge RMS test voltage ( $q_m < 5$ pC)	$U_t$	V	990	Primary/secondary According to IEC 60950-1
Creepage distance (pri. - sec.)	$d_{cp}$	mm	8	Shortest path along device body
Clearance (pri. - sec.)	$d_{cl}$	mm	8	Shortest mounted on PCB with recommended layout
Case material	-	-	V0	According to UL 94
Comparative tracking index	$CTI$	-	600	
Application example	-	V	600	Reinforced insulation, CAT III, PD 2, according to IEC 62109-1 Altitude $\leq$ 3000 m

**Environmental and mechanical characteristics**

Parameter	Symbol	Unit	Min	Typ	Max	Comment
Ambient operating temperature	$T_A$	$^{\circ}$ C	-40		125	
Ambient storage temperature	$T_s$	$^{\circ}$ C	-55		165	
Resistance of the primary @ $T_A = 25$ $^{\circ}$ C	$R_p$	m $\Omega$		0.76		
Thermal resistance junction to board	$R_{th_{JB}}$	$^{\circ}$ K/W		TBD		
Mass	$m$	g			1	TBD

S P E C I M E N T

**Absolute maximum ratings**

Parameter	Symbol	Unit	Value
Supply voltage (not destructive)	$U_c$	V	8
Supply voltage (not entering non standard modes)	$U_c$	V	6.5
Electrostatic discharge voltage (HBM - Human Body Model)	$U_{ESD\ HBM}$	kV	2
Maximum output current source	$I_{out\ max}$	mA	25
Maximum input current sink	$I_{in\ max}$	mA	50
Maximum junction temperature	$T_{J\ max}$	°C	150

Stresses above these ratings may cause permanent damage. Exposure to absolute maximum ratings for extended periods may degrade reliability.

S P E C I M E N T

**Electrical data HMSR 6-SMS**

 At  $T_A = 25\text{ °C}$ ,  $U_C = +5$ ,  $R_L = 10\text{ k}\Omega$  unless otherwise noted (see Min, Max, typ. definition paragraph in page 10).

Parameter	Symbol	Unit	Min	Typ	Max	Comment
Primary nominal RMS current	$I_{PN}$	A		6		
Primary current, measuring range	$I_{PM}$	A	-15		15	
Supply voltage <sup>1)</sup>	$U_C$	V	4.5	5	5.5	
Current consumption	$I_C$	mA		20	26	
Reference voltage (output)	$V_{ref}$	V	2.48	2.5	2.52	Internal reference
Reference voltage (input)	$V_{ref}$	V	0.5		2.6	External reference
Output voltage range @ $I_{PM}$	$V_{out} - V_{ref}$	V	-2		2	
$V_{ref}$ output resistance	$R_{ref}$	$\Omega$	120	200	333	
$V_{out}$ output resistance	$R_{out}$	$\Omega$		2	5	
Capacity loading	$C_L$	nF	0		6	
Electrical offset voltage @ $I_P = 0$	$V_{OE}$	mV	-5		5	$V_{out} - V_{ref} @ V_{ref} = 2.5\text{ V}$
Electrical offset current, referred to primary	$I_{OE}$	mA	-37.5		37.5	
Temperature coefficient of $V_{ref}$	$TCV_{ref}$	ppm/K	-150		150	-40 °C ... 105 °C
Temperature coefficient of $V_{OE}$	$TCV_{OE}$	mV/K	-0.075		0.075	-40 °C ... 105 °C
Temperature coefficient of $I_{OE}$	$TCI_{OE}$	mA/K	-0.6		0.6	-40 °C ... 105 °C
Theoretical sensitivity	$G_{th}$	mV/A		133.33		800 mV @ $I_{PN}$
Sensitivity error	$\varepsilon_G$	%	-0.75		0.75	Factory adjustment
Temperature coefficient of $G$	$TCG$	ppm/K	-200		200	-40 °C ... 105 °C
Linearity error 0 ... $I_{PN}$	$\varepsilon_L$	% of $I_{PN}$	-0.75		0.75	
Linearity error 0 ... $I_{PM}$	$\varepsilon_L$	% of $I_{PM}$	-0.5		0.5	
Magnetic offset current (@ $10 \times I_{PN}$ ) referred to primary	$I_{OM}$	A	TBD		TBD	
Output RMS noise voltage spectral density 100 Hz... 100 kHz	$e_{no}$	$\mu\text{V}/\sqrt{\text{Hz}}$			TBD	$NBW = 1\text{ kHz} \dots 100\text{ kHz}$
Output RMS noise voltage DC ... 10 kHz DC ... 100 kHz DC ... 10 MHz	$V_{no}$	mVpp		TBD TBD TBD		
Reaction time @ 10 % of $I_{PN}$	$t_{ra}$	$\mu\text{s}$			2	TBD
Step response time to 90 % of $I_{PN}$	$t_r$	$\mu\text{s}$			2.1	TBD
Frequency bandwidth (-3 dB)	$BW$	kHz		300		TBD
Internal overcurrent detection (OCD) threshold	$I_{IOCD}$	A		$2.93 \times I_{PN}$		Factory setting EEPROM
Internal OCD threshold accuracy	$X_{IOCD}$	%	-10		10	
Internal OCD output on resistance	$R_{onIOCD}$	$\Omega$	70	95	100	open drain output, active low
Internal OCD output hold time	$t_{holdIOCD}$	$\mu\text{s}$	7	10	14	
Internal OCD response time	$t_{rIOCD}$	$\mu\text{s}$	1.4		2.1	2 signal peaks detected
Accuracy @ $I_{PN}$	$X$	% of $I_{PN}$	-1.5		1.5	
Accuracy @ $I_{PN}$ @ $T_A = +85\text{ °C}$	$X$	% of $I_{PN}$	-3.26		3.26	See formula note <sup>2)</sup>
Accuracy @ $I_{PN}$ @ $T_A = +105\text{ °C}$	$X$	% of $I_{PN}$	-3.85		3.85	See formula note <sup>2)</sup>
Accuracy @ $I_{PN}$ @ $T_A = +125\text{ °C}$	$X$	% of $I_{PN}$	-4.44		4.44	See formula note <sup>2)</sup>

 Notes: <sup>1)</sup> 3.3 V SP version available

$$\text{Accuracy @ } T_A (\% \text{ of } I_{PN}) = X + \left( \frac{TCG}{10000} \times (T_A - 25) \right) + \left( \frac{TCI_{OE}}{1000 \times I_{PN}} \times 100 \times (T_A - 25) \right).$$

**Electrical data HMSR 8-SMS**

 At  $T_A = 25\text{ °C}$ ,  $U_C = +5$ ,  $R_L = 10\text{ k}\Omega$  unless otherwise noted (see Min, Max, typ. definition paragraph in page 10).

Parameter	Symbol	Unit	Min	Typ	Max	Comment
Primary nominal RMS current	$I_{PN}$	A		8		
Primary current, measuring range	$I_{PM}$	A	-20		20	
Supply voltage <sup>1)</sup>	$U_C$	V	4.5	5	5.5	
Current consumption	$I_C$	mA		20	26	
Reference voltage (output)	$V_{ref}$	V	2.48	2.5	2.52	Internal reference
Reference voltage (input)	$V_{ref}$	V	0.5		2.6	External reference
Output voltage range @ $I_{PM}$	$V_{out} - V_{ref}$	V	-2		2	
$V_{ref}$ output resistance	$R_{ref}$	$\Omega$	120	200	333	
$V_{out}$ output resistance	$R_{out}$	$\Omega$		2	5	
Capacity loading	$C_L$	nF	0		6	
Electrical offset voltage @ $I_P = 0$	$V_{OE}$	mV	-5		5	$V_{out} - V_{ref}$ @ $V_{ref} = 2.5\text{ V}$
Electrical offset current, referred to primary	$I_{OE}$	mA	-50		50	
Temperature coefficient of $V_{ref}$	$TCV_{ref}$	ppm/K	-150		150	-40 °C ... 105 °C
Temperature coefficient of $V_{OE}$	$TCV_{OE}$	mV/K	-0.075		0.075	-40 °C ... 105 °C
Temperature coefficient of $I_{OE}$	$TCI_{OE}$	mA/K	-0.8		0.8	-40 °C ... 105 °C
Theoretical sensitivity	$G_{th}$	mV/A		100		800 mV @ $I_{PN}$
Sensitivity error	$\varepsilon_G$	%	-0.75		0.75	Factory adjustment
Temperature coefficient of $G$	$TCG$	ppm/K	-200		200	-40 °C ... 105 °C
Linearity error 0 ... $I_{PN}$	$\varepsilon_L$	% of $I_{PN}$	-0.75		0.75	
Linearity error 0 ... $I_{PM}$	$\varepsilon_L$	% of $I_{PM}$	-0.5		0.5	
Magnetic offset current (@ $10 \times I_{PN}$ ) referred to primary	$I_{OM}$	A	TBD		TBD	
Output RMS noise voltage spectral density 100 Hz... 100 kHz	$e_{no}$	$\mu\text{V}/\sqrt{\text{Hz}}$			TBD	$NBW = 1\text{ kHz} \dots 100\text{ kHz}$
Output RMS noise voltage DC ... 10 kHz DC ... 100 kHz DC ... 10 MHz	$V_{no}$	mVpp		TBD TBD TBD		
Reaction time @ 10 % of $I_{PN}$	$t_{ra}$	$\mu\text{s}$			2	TBD
Step response time to 90 % of $I_{PN}$	$t_r$	$\mu\text{s}$			2.1	TBD
Frequency bandwidth (-3 dB)	$BW$	kHz		300		TBD
Internal overcurrent detection (OCD) threshold	$I_{IOCD}$	A		$2.93 \times I_{PN}$		Factory setting EEPROM
Internal OCD threshold accuracy	$X_{IOCD}$	%	-10		10	
Internal OCD output on resistance	$R_{onIOCD}$	$\Omega$	70	95	100	open drain output, active low
Internal OCD output hold time	$t_{holdIOCD}$	$\mu\text{s}$	7	10	14	
Internal OCD response time	$t_{rIOCD}$	$\mu\text{s}$	1.4		2.1	2 signal peaks detected
Accuracy @ $I_{PN}$	$X$	% of $I_{PN}$	-1.5		1.5	
Accuracy @ $I_{PN}$ @ $T_A = +85\text{ °C}$	$X$	% of $I_{PN}$	-3.26		3.26	See formula note <sup>2)</sup>
Accuracy @ $I_{PN}$ @ $T_A = +105\text{ °C}$	$X$	% of $I_{PN}$	-3.85		3.85	See formula note <sup>2)</sup>
Accuracy @ $I_{PN}$ @ $T_A = +125\text{ °C}$	$X$	% of $I_{PN}$	-4.44		4.44	See formula note <sup>2)</sup>

 Notes: <sup>1)</sup> 3.3 V SP version available

$$\text{Accuracy @ } I_A (\% \text{ of } I_{PN}) = X + \left( \frac{TCG}{10000} \times (T_A - 25) \right) + \left( \frac{TCI_{OE}}{1000 \times I_{PN}} \times 100 \times (T_A - 25) \right).$$

**Electrical data HMSR 10-SMS**

 At  $T_A = 25\text{ °C}$ ,  $U_C = +5$ ,  $R_L = 10\text{ k}\Omega$  unless otherwise noted (see Min, Max, typ. definition paragraph in page 10).

Parameter	Symbol	Unit	Min	Typ	Max	Comment
Primary nominal RMS current	$I_{PN}$	A		10		
Primary current, measuring range	$I_{PM}$	A	-25		25	
Supply voltage <sup>1)</sup>	$U_C$	V	4.5	5	5.5	
Current consumption	$I_C$	mA		20	26	
Reference voltage (output)	$V_{ref}$	V	2.48	2.5	2.52	Internal reference
Reference voltage (input)	$V_{ref}$	V	0.5		2.6	External reference
Output voltage range @ $I_{PM}$	$V_{out} - V_{ref}$	V	-2		2	
$V_{ref}$ output resistance	$R_{ref}$	$\Omega$	120	200	333	
$V_{out}$ output resistance	$R_{out}$	$\Omega$		2	5	
Capacity loading	$C_L$	nF	0		6	
Electrical offset voltage @ $I_P = 0$	$V_{OE}$	mV	-5		5	$V_{out} - V_{ref} @ V_{ref} = 2.5\text{ V}$
Electrical offset current, referred to primary	$I_{OE}$	mA	-62.5		62.5	
Temperature coefficient of $V_{ref}$	$TCV_{ref}$	ppm/K	-180		180	-40 °C ... 105 °C
Temperature coefficient of $V_{OE}$	$TCV_{OE}$	mV/K	-0.075		0.075	-40 °C ... 105 °C
Temperature coefficient of $I_{OE}$	$TCI_{OE}$	mA/K	-0.9		0.9	-40 °C ... 105 °C
Theoretical sensitivity	$G_{th}$	mV/A		80		800 mV @ $I_{PN}$
Sensitivity error	$\epsilon_G$	%	-0.75		0.75	Factory adjustment
Temperature coefficient of $G$	$TCG$	ppm/K	-200		200	-40 °C ... 105 °C
Linearity error 0 ... $I_{PN}$	$\epsilon_L$	% of $I_{PN}$	-0.5		0.5	
Linearity error 0 ... $I_{PM}$	$\epsilon_L$	% of $I_{PM}$	-0.5		0.5	
Magnetic offset current (@ $10 \times I_{PN}$ ) referred to primary	$I_{OM}$	A	TBD		TBD	
Output RMS noise voltage spectral density 100 Hz... 100 kHz	$e_{no}$	$\mu\text{V}/\sqrt{\text{Hz}}$			TBD	$NBW = 1\text{ kHz} \dots 100\text{ kHz}$
Output RMS noise voltage DC ... 10 kHz DC ... 100 kHz DC ... 10 MHz	$V_{no}$	mVpp		TBD TBD TBD		
Reaction time @ 10 % of $I_{PN}$	$t_{ra}$	$\mu\text{s}$			2	TBD
Step response time to 90 % of $I_{PN}$	$t_r$	$\mu\text{s}$			2.1	TBD
Frequency bandwidth (-3 dB)	$BW$	kHz		300		TBD
Internal overcurrent detection (OCD) threshold	$I_{IOCD}$	A		$2.93 \times I_{PN}$		Factory setting EEPROM
Internal OCD threshold accuracy	$X_{IOCD}$	%	-10		10	
Internal OCD output on resistance	$R_{onIOCD}$	$\Omega$	70	95	100	open drain output, active low
Internal OCD output hold time	$t_{holdIOCD}$	$\mu\text{s}$	7	10	14	
Internal OCD response time	$t_{rIOCD}$	$\mu\text{s}$	1.4		2.1	2 signal peaks detected
Accuracy @ $I_{PN}$	$X$	% of $I_{PN}$	-1.25		1.25	
Accuracy @ $I_{PN}$ @ $T_A = +85\text{ °C}$	$X$	% of $I_{PN}$	-3.01		3.01	See formula note <sup>2)</sup>
Accuracy @ $I_{PN}$ @ $T_A = +105\text{ °C}$	$X$	% of $I_{PN}$	-3.60		3.60	See formula note <sup>2)</sup>
Accuracy @ $I_{PN}$ @ $T_A = +125\text{ °C}$	$X$	% of $I_{PN}$	-4.19		4.19	See formula note <sup>2)</sup>

 Notes: <sup>1)</sup> 3.3 V SP version available

$$\text{Accuracy @ } T_A \text{ (% of } I_{PN}) = X + \left( \frac{TCG}{10000} \times (T_A - 25) \right) + \left( \frac{TCI_{OE}}{1000 \times I_{PN}} \times 100 \times (T_A - 25) \right).$$

**Electrical data HMSR 20-SMS**

 At  $T_A = 25\text{ °C}$ ,  $U_C = +5$ ,  $R_L = 10\text{ k}\Omega$  unless otherwise noted (see Min, Max, typ. definition paragraph in page 10).

Parameter	Symbol	Unit	Min	Typ	Max	Comment
Primary nominal RMS current	$I_{PN}$	A		20		
Primary current, measuring range	$I_{PM}$	A	-50		50	
Supply voltage <sup>1)</sup>	$U_C$	V	4.5	5	5.5	
Current consumption	$I_C$	mA		20	26	
Reference voltage (output)	$V_{ref}$	V	2.48	2.5	2.52	Internal reference
Reference voltage (input)	$V_{ref}$	V	0.5		2.6	External reference
Output voltage range @ $I_{PM}$	$V_{out} - V_{ref}$	V	-2		2	
$V_{ref}$ output resistance	$R_{ref}$	$\Omega$	120	200	333	
$V_{out}$ output resistance	$R_{out}$	$\Omega$		2	5	
Capacity loading	$C_L$	nF	0		6	
Electrical offset voltage @ $I_P = 0$	$V_{OE}$	mV	-5		5	$V_{out} - V_{ref} @ V_{ref} = 2.5\text{ V}$
Electrical offset current, referred to primary	$I_{OE}$	mA	-125		125	
Temperature coefficient of $V_{ref}$	$TCV_{ref}$	ppm/K	-180		180	-40 °C ... 105 °C
Temperature coefficient of $V_{OE}$	$TCV_{OE}$	mV/K	-0.075		0.075	-40 °C ... 105 °C
Temperature coefficient of $I_{OE}$	$TCI_{OE}$	mA/K	-1.9		1.9	-40 °C ... 105 °C
Theoretical sensitivity	$G_{th}$	mV/A		40		800 mV @ $I_{PN}$
Sensitivity error	$\epsilon_G$	%	-0.75		0.75	Factory adjustment
Temperature coefficient of $G$	$TCG$	ppm/K	-200		200	-40 °C ... 105 °C
Linearity error 0 ... $I_{PN}$	$\epsilon_L$	% of $I_{PN}$	-0.5		0.5	
Linearity error 0 ... $I_{PM}$	$\epsilon_L$	% of $I_{PM}$	-0.5		0.5	
Magnetic offset current (@ $10 \times I_{PN}$ ) referred to primary	$I_{OM}$	A	TBD		TBD	
Output RMS noise voltage spectral density 100 Hz... 100 kHz	$e_{no}$	$\mu\text{V}/\sqrt{\text{Hz}}$			TBD	$NBW = 1\text{ kHz} \dots 100\text{ kHz}$
Output RMS noise voltage DC ... 10 kHz DC ... 100 kHz DC ... 10 MHz	$V_{no}$	mVpp		TBD TBD TBD		
Reaction time @ 10 % of $I_{PN}$	$t_{ra}$	$\mu\text{s}$			2	TBD
Step response time to 90 % of $I_{PN}$	$t_r$	$\mu\text{s}$			2.1	TBD
Frequency bandwidth (-3 dB)	$BW$	kHz		300		TBD
Internal overcurrent detection (OCD) threshold	$I_{IOCD}$	A		$2.93 \times I_{PN}$		Factory setting EEPROM
Internal OCD threshold accuracy	$X_{IOCD}$	%	-10		10	
Internal OCD output on resistance	$R_{onIOCD}$	$\Omega$	70	95	100	open drain output, active low
Internal OCD output hold time	$t_{holdIOCD}$	$\mu\text{s}$	7	10	14	
Internal OCD response time	$t_{rIOCD}$	$\mu\text{s}$	1.4		2.1	2 signal peaks detected
Accuracy @ $I_{PN}$	$X$	% of $I_{PN}$	-1.25		1.25	
Accuracy @ $I_{PN}$ @ $T_A = +85\text{ °C}$	$X$	% of $I_{PN}$	-3.01		3.01	See formula note <sup>2)</sup>
Accuracy @ $I_{PN}$ @ $T_A = +105\text{ °C}$	$X$	% of $I_{PN}$	-3.60		3.60	See formula note <sup>2)</sup>
Accuracy @ $I_{PN}$ @ $T_A = +125\text{ °C}$	$X$	% of $I_{PN}$	-4.19		4.19	See formula note <sup>2)</sup>

 Notes: <sup>1)</sup> 3.3 V SP version available

$$\text{Accuracy @ } T_A \text{ (\% of } I_{PN}) = X + \left( \frac{TCG}{10000} \times (T_A - 25) \right) + \left( \frac{TCI_{OE}}{1000 \times I_{PN}} \times 100 \times (T_A - 25) \right).$$

**Electrical data HMSR 30-SMS**

 At  $T_A = 25\text{ °C}$ ,  $U_C = +5$ ,  $R_L = 10\text{ k}\Omega$  unless otherwise noted (see Min, Max, typ. definition paragraph in page 10).

Parameter	Symbol	Unit	Min	Typ	Max	Comment
Primary nominal RMS current	$I_{PN}$	A		30		
Primary current, measuring range	$I_{PM}$	A	-75		75	
Supply voltage <sup>1)</sup>	$U_C$	V	4.5	5	5.5	
Current consumption	$I_C$	mA		20	26	
Reference voltage (output)	$V_{ref}$	V	2.48	2.5	2.52	Internal reference
Reference voltage (input)	$V_{ref}$	V	0.5		2.6	External reference
Output voltage range @ $I_{PM}$	$V_{out} - V_{ref}$	V	-2		2	
$V_{ref}$ output resistance	$R_{ref}$	$\Omega$	120	200	333	
$V_{out}$ output resistance	$R_{out}$	$\Omega$		2	5	
Capacity loading	$C_L$	nF	0		6	
Electrical offset voltage @ $I_p = 0$	$V_{OE}$	mV	-5		5	$V_{out} - V_{ref} @ V_{ref} = 2.5\text{ V}$
Electrical offset current, referred to primary	$I_{OE}$	mA	-187.5		187.5	
Temperature coefficient of $V_{ref}$	$TCV_{ref}$	ppm/K	-180		180	-40 °C ... 105 °C
Temperature coefficient of $V_{OE}$	$TCV_{OE}$	mV/K	-0.075		0.075	-40 °C ... 105 °C
Temperature coefficient of $I_{OE}$	$TCI_{OE}$	mA/K	-2.8		2.8	-40 °C ... 105 °C
Theoretical sensitivity	$G_{th}$	mV/A		26.67		800 mV @ $I_{PN}$
Sensitivity error	$\varepsilon_G$	%	-0.75		0.75	Factory adjustment
Temperature coefficient of $G$	$TCG$	ppm/K	-200		200	-40 °C ... 105 °C
Linearity error 0 ... $I_{PN}$	$\varepsilon_L$	% of $I_{PN}$	-0.5		0.5	
Linearity error 0 ... $I_{PM}$	$\varepsilon_L$	% of $I_{PM}$	-0.5		0.5	
Magnetic offset current (@ $10 \times I_{PN}$ ) referred to primary	$I_{OM}$	A	TBD		TBD	
Output RMS noise voltage spectral density 100 Hz... 100 kHz	$e_{no}$	$\mu\text{V}/\sqrt{\text{Hz}}$			TBD	$NBW = 1\text{ kHz} \dots 100\text{ kHz}$
Output RMS noise voltage DC ... 10 kHz DC ... 100 kHz DC ... 10 MHz	$V_{no}$	mVpp		TBD TBD TBD		
Reaction time @ 10 % of $I_{PN}$	$t_{ra}$	$\mu\text{s}$			2	TBD
Step response time to 90 % of $I_{PN}$	$t_r$	$\mu\text{s}$			2.1	TBD
Frequency bandwidth (-3 dB)	$BW$	kHz		300		TBD
Internal overcurrent detection (OCD) threshold	$I_{IOCD}$	A		$2.93 \times I_{PN}$		Factory setting EEPROM
Internal OCD threshold accuracy	$X_{IOCD}$	%	-10		10	
Internal OCD output on resistance	$R_{onIOCD}$	$\Omega$	70	95	100	open drain output, active low
Internal OCD output hold time	$t_{holdIOCD}$	$\mu\text{s}$	7	10	14	
Internal OCD response time	$t_{rIOCD}$	$\mu\text{s}$	1.4		2.1	2 signal peaks detected
Accuracy @ $I_{PN}$	$X$	% of $I_{PN}$	-1.25		1.25	
Accuracy @ $I_{PN}$ @ $T_A = +85\text{ °C}$	$X$	% of $I_{PN}$	-3.01		3.01	See formula note <sup>2)</sup>
Accuracy @ $I_{PN}$ @ $T_A = +105\text{ °C}$	$X$	% of $I_{PN}$	-3.60		3.60	See formula note <sup>2)</sup>
Accuracy @ $I_{PN}$ @ $T_A = +125\text{ °C}$	$X$	% of $I_{PN}$	-4.19		4.19	See formula note <sup>2)</sup>

 Notes: <sup>1)</sup> 3.3 V SP version available

$$\text{Accuracy @ } T_A \text{ (\% of } I_{PN}) = X + \left( \frac{TCG}{10000} \times (T_A - 25) \right) + \left( \frac{TCI_{OE}}{1000 \times I_{PN}} \times 100 \times (T_A - 25) \right).$$



External overcurrent detection

Parameter	Symbol	Unit	Specification			Conditions
			Min	Typical	Max	
External OCD voltage	$U_{E\text{OCD}}$	V	0.3		2	
External OCD output on resistance to ground	$R_{\text{on } E\text{OCD}}$	$\Omega$	35	200	300	
External OCD response time	$t_{r\text{E OCD}}$	$\mu\text{s}$		10		To be added to the sensor response time
External OCD output hold time	$t_{\text{hold } E\text{OCD}}$	$\mu\text{s}$		10		
External OCD threshold error	$\varepsilon_{E\text{OCD}}$	% of $I_{PN}$		$\pm 5$		Switch point error between $V_{\text{out}}$ and $U_{E\text{OCD}}$

$I_{E\text{OCD}}$ : External overcurrent detection (OCD threshold)

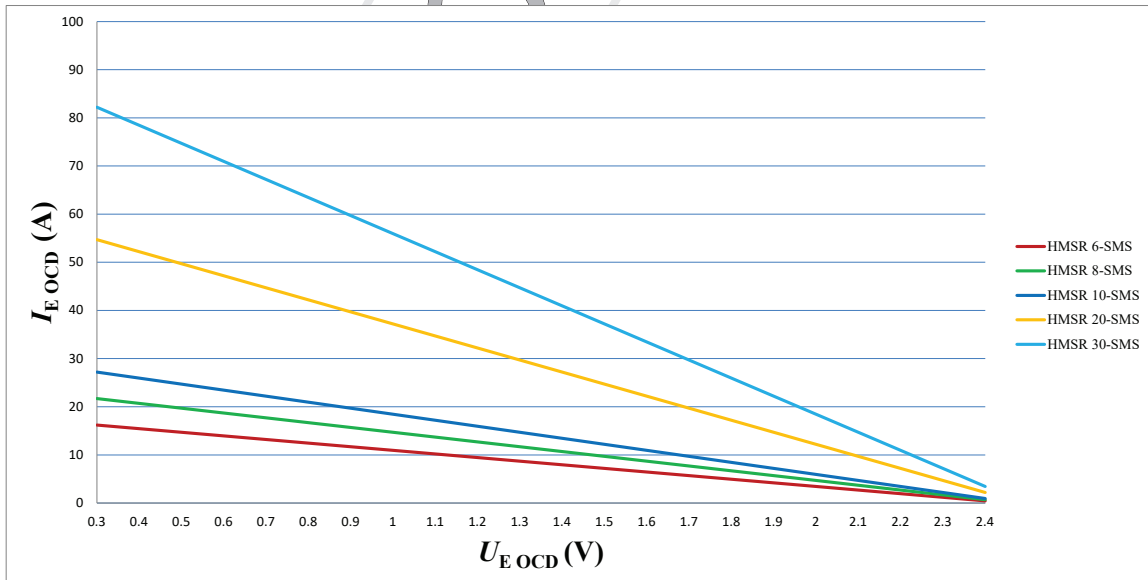
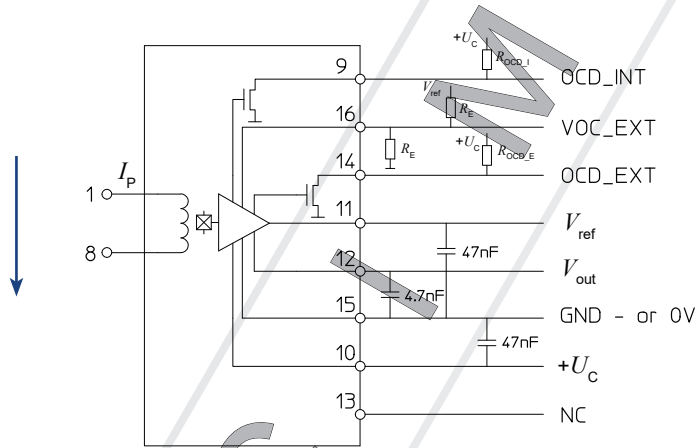

$$I_{E\text{OCD}} = \frac{(V_{\text{ref}} - U_{E\text{OCD}})}{G_{\text{Th}}} \times 1000 \quad U_{E\text{OCD}} = \frac{R_E}{R_E + R_{\text{ref}}} \times V_{\text{ref}}$$

## Packaging

To be defined.

### Definition of typical, minimum and maximum values

Minimum and maximum values for specified limiting and safety conditions have to be understood as such as well as values shown in “typical” graphs.

On the other hand, measured values are part of a statistical distribution that can be specified by an interval with upper and lower limits and a probability for measured values to lie within this interval.

Unless otherwise stated (e.g. “100 % tested”), the LEM definition for such intervals designated with “min” and “max” is that the probability for values of samples to lie in this interval is 99.73 %.

For a normal (Gaussian) distribution, this corresponds to an interval between  $-3$  sigma and  $+3$  sigma. If “typical” values are not obviously mean or average values, those values are defined to delimit intervals with a probability of 68.27 %, corresponding to an interval between  $-\text{sigma}$  and  $+\text{sigma}$  for a normal distribution.

Typical, maximal and minimal values are determined during the initial characterization of the product.

S P E C I M E N

HMSR-SMS series, measuring range versus external reference voltage

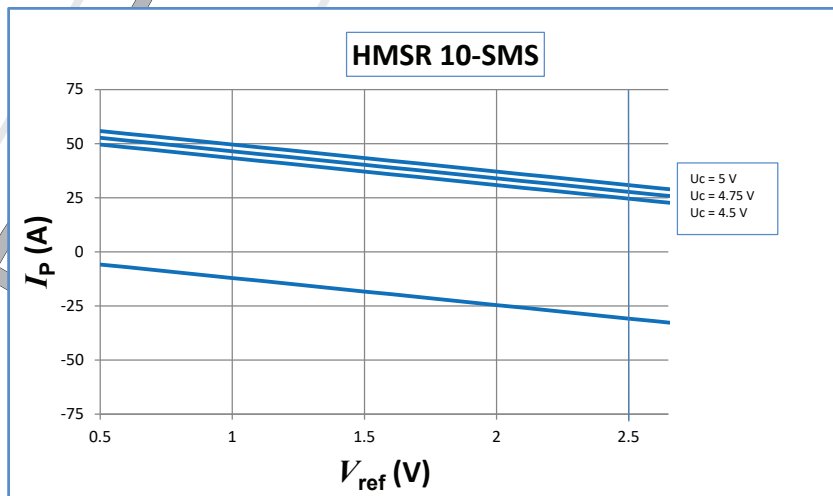
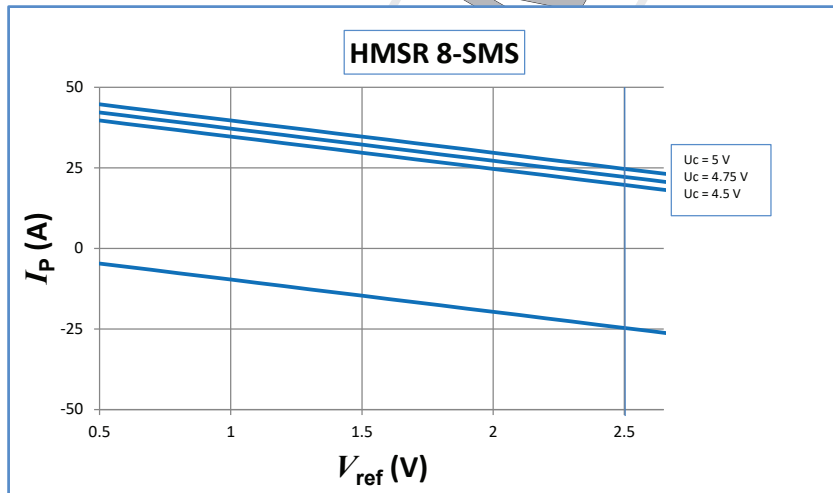
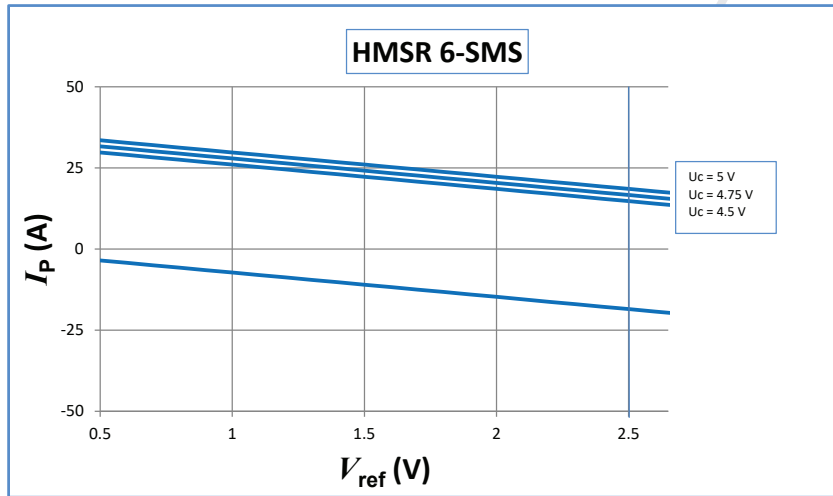

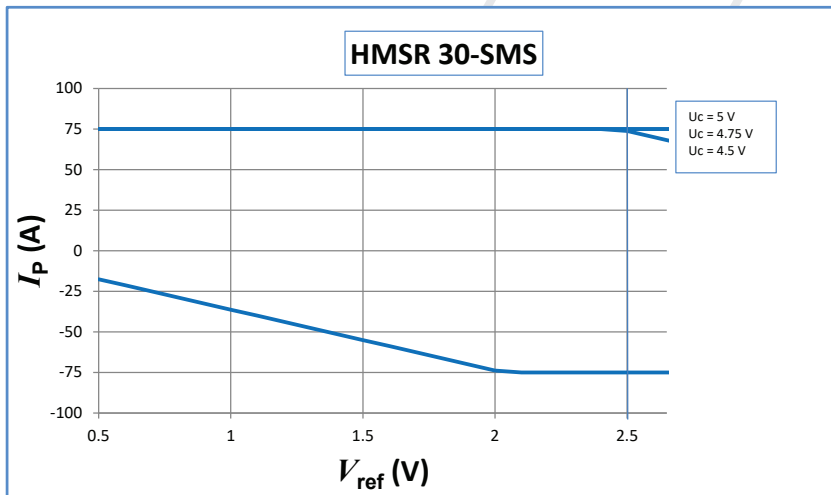
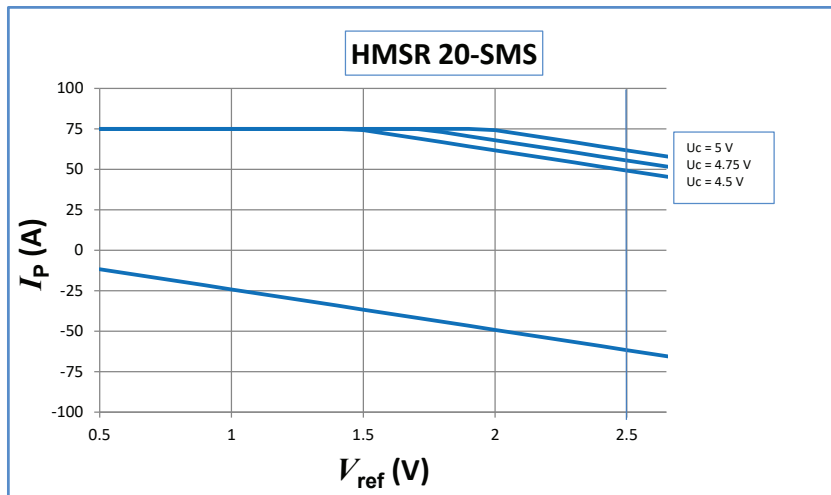

S P E C I F I C A T I O N

HMSR-SMS series, PCB footprint (in mm)

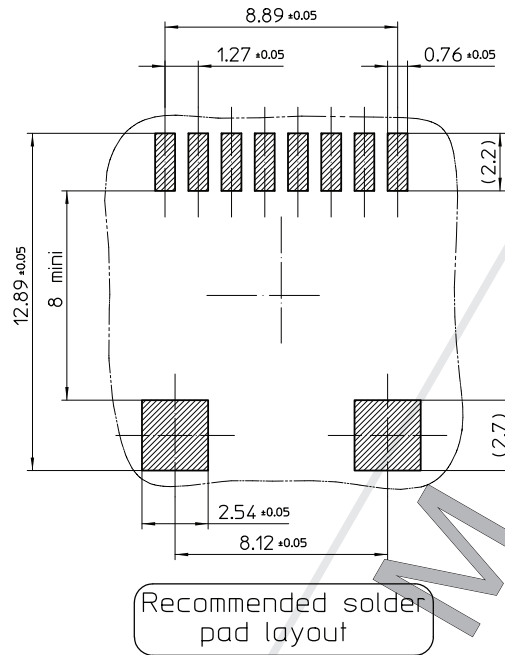

	$d_{Cl}$ (mm)	$d_{Cp}$ (mm)
A-B	8	8

**Assembly on PCB**

- Wave soldering profile  
No clean process only.

maximum 260 °C for 10 s

**Safety**

This transducer must be used in limited-energy secondary circuits according to IEC 61010-1.



This transducer must be used in electric/electronic equipment with respect to applicable standards and safety requirements in accordance with the manufacturer's operating instructions.



Caution, risk of electrical shock

When operating the transducer, certain parts of the module can carry hazardous voltage (e.g. primary busbar, power supply). Ignoring this warning can lead to injury and/or cause serious damage.

This transducer is a build-in device, whose conducting parts must be inaccessible after installation.

A protective housing or additional shield could be used. Main supply must be able to be disconnected.

**Dimensions** (in mm. General linear tolerance  $\pm 0.15$  mm)

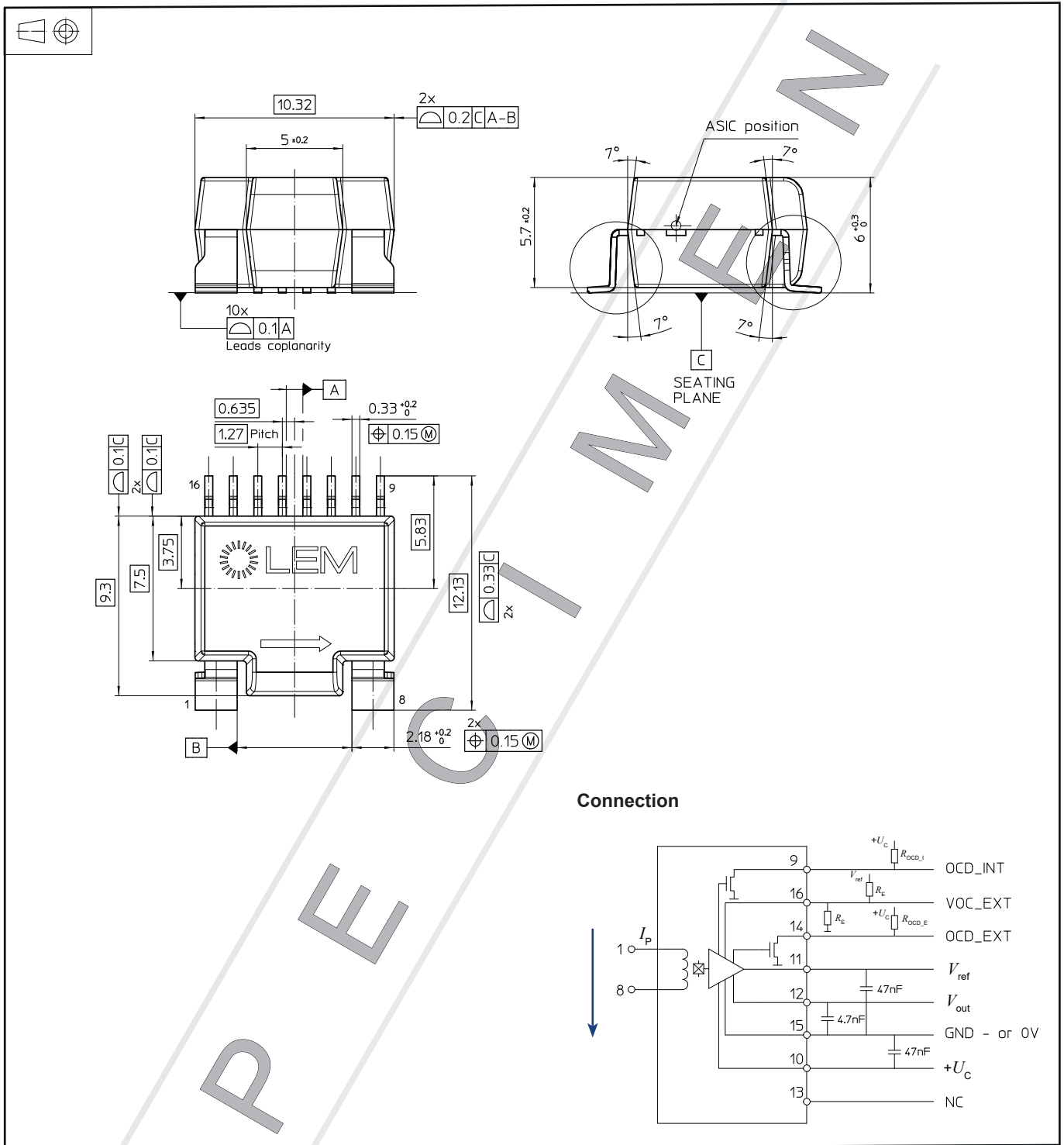

**Remarks**

- $V_{out}$  is positive with respect to  $V_{ref}$  when positive  $I_P$  flows in direction of the arrow shown on the drawing above
- Installation of the transducer must be done unless otherwise specified on the datasheet, according to LEM Transducer Generic Mounting Rules. Please refer to LEM document N°ANE120504 available on our Web site: [Products/Product Documentation](#).