

Voltage Transducer CV 3-1000

For the electronic measurement of voltages: DC, AC, pulsed..., with galvanic separation between the primary circuit and the secondary circuit.



$$U_{PN} = 700 \text{ V}$$



Electrical data

U_{PN}	Primary nominal RMS voltage	700	V
U_{PM}	Primary voltage, measuring range	0 ... ± 1000	V
U_S	Secondary voltage @ U_{Pmax}	10	V
N_P/N_S	Turns ratio	1000 V : 10	V
R_L	Load resistance	≥ 1	k Ω
C_L	Load capacitance	≤ 5	nF
U_C	Supply voltage ($\pm 5\%$)	± 15	V
I_C	Current consumption	$32 + U_S / R_L$	mA

Accuracy - Dynamic performance data

			Max	
ϵ_{tot}	Total error @ U_{PN}	$T_A = 25^\circ\text{C}$	± 0.2	%
		$-40 \dots +85^\circ\text{C}$	± 0.6	%
U_O	Offset voltage @ $U_P = 0$, $T_A = 25^\circ\text{C}$		± 5	mV
		$-40 \dots +85^\circ\text{C}$	± 13	mV
t_{D90}	Delay time to 90 % of the final output value for U_{PN} step ¹⁾		0.3	μs
BW	Frequency bandwidth (-1 dB) @ U_{PN}		DC ... 500	kHz

General data

T_A	Ambient operating temperature	$-40 \dots +85$	$^\circ\text{C}$
T_{Ast}	Ambient storage temperature	$-45 \dots +90$	$^\circ\text{C}$
P_P	Total primary power loss	3.1	W
R_P	Resistance of primary (winding)	160	k Ω
m	Mass	550	g
	Standards	EN 50155: 2007 ²⁾	
		EN 50121-3-2: 2015	

Notes: ¹⁾ For a $dv/dt = 800 \text{ V}/\mu\text{s}$

²⁾ Deviation of the offset during the test IEC 61000-4-3 between 100 to 200 MHz.

Features

- Closed loop (compensated) voltage transducer using the Hall effect
- Insulating plastic case recognized according to UL 94-V0.

Advantages

- Excellent accuracy
- Very good linearity
- Low temperature drift
- Optimized delay time
- Wide frequency bandwidth
- High immunity to external interference
- Low disturbance in common mode.

Applications

- Single or three phase inverters
- Propulsion and braking choppers
- Propulsion converters
- Auxiliary converters
- Battery chargers.

Application Domain

- Railway (fixed installations and onboard).

Voltage Transducer CV 3-1000

Insulation coordination

U_d	RMS voltage for AC insulation test, 50 Hz, 1 min	6	kV
U_t	Partial discharge RMS test voltage ($q_m < 10$ pC)	2	kV
		Min	
d_{cp}	Creepage distance	83.8	mm
d_{cl}	Clearance	76.4	mm
CTI	Comparative tracking index (group I)	600	

Safety

This transducer must be used in limited-energy secondary circuits according to IEC 61010-1.



This transducer must be used in electric/electronic equipment with respect to applicable standards and safety requirements in accordance with the manufacturer's operating instructions.



Caution, risk of electrical shock

When operating the transducer, certain parts of the module can carry hazardous voltage (e.g. primary connections, power supply).

Ignoring this warning can lead to injury and/or cause serious damage.

This transducer is a build-in device, whose conducting parts must be inaccessible after installation.

A protective housing or additional shield could be used.

Main supply must be able to be disconnected.

Dimensions CV 3-1000 (in mm)

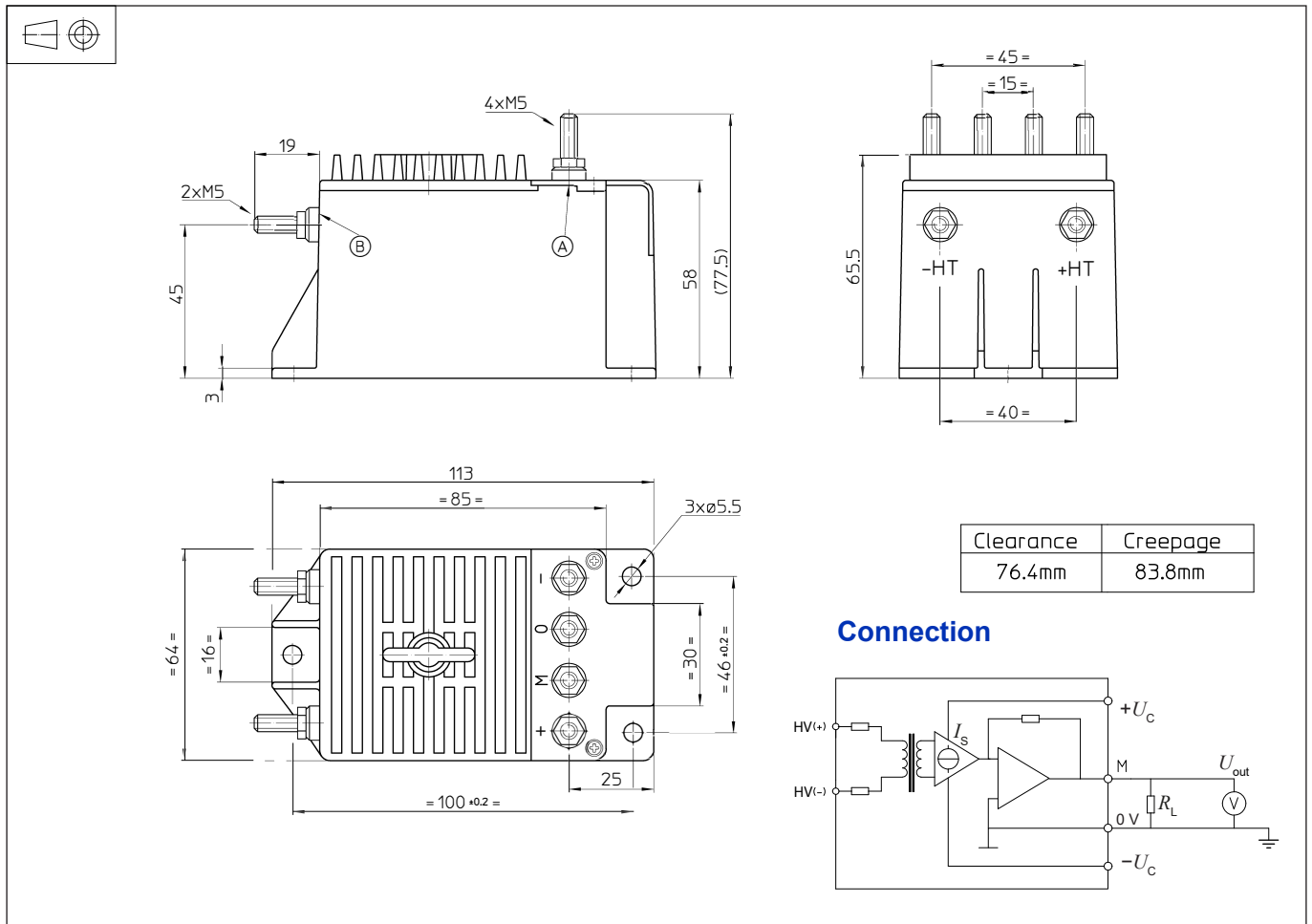

Mechanical characteristics

- General tolerance ± 0.3 mm
- Transducer fastening
 - 3 holes $\varnothing 5.5$ mm
 - 3 steel screws M5
- Recommended fastening torque 3.8 N·m
- Connection of primary 2 threaded studs M5
- Connection of secondary 4 threaded studs M5
- Recommended fastening torque 2.2 N·m

Remarks

- U_s is positive when U_p is applied on terminal +HV.
- EMC tested with a shielded secondary cable, shield connected to 0 V at both ends, or disconnected.
- Installation of the transducer must be done unless otherwise specified on the datasheet, according to LEM Transducer Generic Mounting Rules. Please refer to LEM document N°ANE120504 available on our Web site: <https://www.lem.com/en/file/3137/download>
- This is a standard model. For different versions (supply voltages, turns ratios, unidirectional measurements...), please contact us.