

# Voltage Transducer CV 4-6000/SP1

For the electronic measurement of voltages: DC, AC, pulsed..., with galvanic separation between the primary circuit and the secondary circuit.



$$U_{PN} = 4200 \text{ V}$$

## Electrical data

$U_{PN}$	Primary nominal RMS voltage	4200	V
$U_{PM}$	Primary voltage, measuring range	0 ... $\pm 6000$	V
$I_{SN}$	Secondary nominal RMS current	70	mA
$S$	Sensitivity	4200 V / 70	mA
$R_M$	Measuring resistance	$R_{M \min}$ $R_{M \max}$	
	with $\pm 24$ V	@ $\pm 4200 \text{ V}_{\max}$ @ $\pm 6000 \text{ V}_{\max}$	50 100 $\Omega$ 50 70 $\Omega$
$U_C$	Supply voltage ( $\pm 10$ %)	$\pm 24$	V
$I_C$	Current consumption @ $U_C = \pm 24$ V	50 + $I_S$	mA

## Accuracy - Dynamic performance data

		Max	
$\varepsilon_{\text{tot}}$	Total error @ $U_{PN}, T_A = 25$ °C	$\pm 0.40$	%
	-40 °C ... +70 °C	$\pm 1.00$	%
$I_O$	Offset current @ $U_P = 0, T_A = 25$ °C	$\pm 0.15$	mA
	-40 °C ... +70 °C	$\pm 0.25$	mA
$t_{D90}$	Delay time to 90 % of the final output value for $U_{PN}$ step <sup>1)</sup>	$\approx 50$	$\mu\text{s}$
$BW$	Frequency bandwidth (-3 dB) @ 50 % $U_{PN}$	DC ... 6	kHz

## General data

$T_A$	Ambient operating temperature	-40 ... +70	°C
$T_{A \text{st}}$	Ambient storage temperature	-50 ... +85	°C
$P_P$	Total primary power loss @ $U_{PN}$	4.2	W
$R_P$	Resistance of primary	4.2	M $\Omega$
$m$	Mass	660	g
	Standards	EN 50178: 1997 EN 50155: 2007 EN 50121-3-2: 2016 <sup>2)</sup>	

Notes: <sup>1)</sup> For a  $dv/dt = 1000 \text{ V}/\mu\text{s}$ .

<sup>2)</sup> Deviation of the offset during the test IEC 61000-4-3 between 100 to 300 MHz.

## Features

- Closed loop (compensated) voltage transducer
- Insulating plastic case recognized according to UL 94-V0.

## Special features

- $I_{SN} = 70$  mA
- $U_C = \pm 24$  ( $\pm 10$  %) V
- $\varepsilon_{\text{tot}} = \pm 0.40$  %
- $T_A = -40$  °C ... +70 °C
- Connection to secondary circuit on AMP CPC 11/4.

## Advantages

- Excellent accuracy
- Very good linearity
- Low temperature drift
- Optimized response time
- Wide frequency bandwidth
- No insertion losses
- High immunity to external interference.

## Applications

- AC variable speed drives and servo motor drives
- Static converters for DC motor drives
- Uninterruptible Power Supplies (UPS)
- Power supplies for welding applications
- Railway overhead line voltage measurement
- Single or three phase inverters
- Propulsion and braking choppers
- Propulsion converters
- Auxiliary converters
- Battery chargers.

## Application Domains

- Railway (fixed installations and onboard)
- Industrial.

## Voltage Transducer CV 4-6000/SP1

### Insulation coordination

$U_d$	RMS voltage for AC insulation test, 50 Hz, 1 min	9.5 <sup>1)</sup>	kV
$U_t$	Partial discharge RMS test voltage ( $q_m < 10$ pC)	3.75 Min	kV
$d_{cp}$	Creepage distance	185.1	mm
$d_{ci}$	Clearance	118.5	mm
CTI	Comparative tracking index (group I)	600	

**Note:** <sup>1)</sup> Between primary and secondary.

### Applications examples

According to EN 50178 and IEC 61010-1 standards and following conditions:

- Over voltage category OV 3
- Pollution degree PD2
- Non-uniform field

	EN 50178	IEC 61010-1
$d_{cp}, d_{ci}, U_{Ni}$	Rated insulation voltage	Nominal voltage
Basic insulation	8000 V	1000 V
Reinforced insulation	5600 V	1000 V

### Safety

This transducer must be used in limited-energy secondary circuits according to IEC 61010-1.



This transducer must be used in electric/electronic equipment with respect to applicable standards and safety requirements in accordance with the manufacturer's operating instructions.



Caution, risk of electrical shock

When operating the transducer, certain parts of the module can carry hazardous voltage (e.g. primary connections, power supply).

Ignoring this warning can lead to injury and/or cause serious damage.

This transducer is a build-in device, whose conducting parts must be inaccessible after installation.

A protective housing or additional shield could be used.

Main supply must be able to be disconnected.

## Dimensions CV 4-6000/SP1 (in mm)

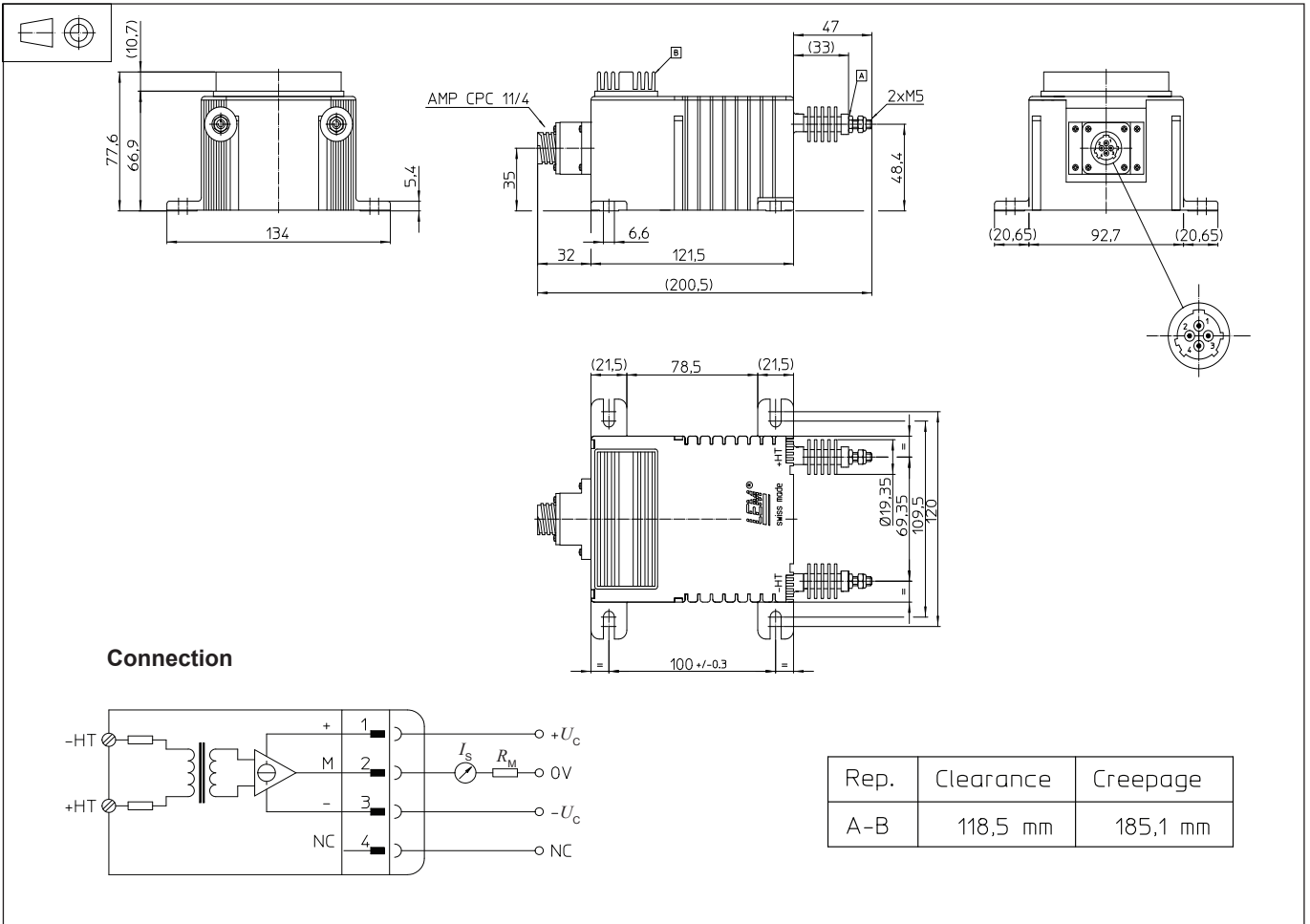

### Mechanical characteristics

- General tolerance  $\pm 0.5$  mm
- Transducer fastening
  - 4 slots  $\varnothing 6.6$  mm
  - 4 M6 steel screws
  - Recommended fastening torque 5 N·m
- Connection of primary
  - M5 threaded studs
  - Recommended fastening torque 2.2 N·m
- Connection of secondary
  - on AMP CPC 11/4 connector

### Remarks

- $I_s$  is positive when  $U_p$  is applied on terminal +HT.
- Installation of the transducer must be done unless otherwise specified on the datasheet, according to LEM Transducer Generic Mounting Rules. Please refer to LEM document N°ANE120504 available on our Web site: <https://www.lem.com/en/file/3137/download/>