

Ref: GO 10-SMS/SP3, GO 20-SMS/SP3, GO 30-SMS/SP3

For the electronic measurement of current: DC, AC, pulsed..., with galvanic separation between the primary and the secondary circuit.

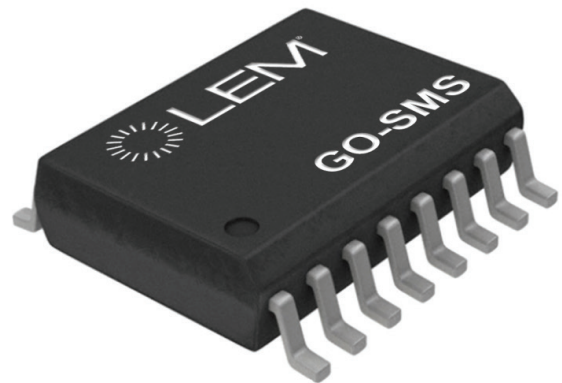

Features

- Hall effect measuring principle
- Galvanic separation between primary and secondary circuit
- Insulated test voltage 3000 V RMS
- Low power consumption
- Extremely low profile
- Double overcurrent detection
- Fixed offset & sensitivity
- Response time 2 μs .

Special feature

- Single power supply +3.3 V.

Advantages

- Small size and space saving
- High immunity to external interference
- High insulation capability
- Low electrical resistance (0.75 m Ω)
- No magnetic hysteresis
- Robust against external fields and cross-talk.

Applications

- Small drives
- HVAC
- Appliances
- E-Bikes
- Solar.

Standards

- IEC 61800-5-1: 2007
- IEC 62109-1: 2010
- IEC 60950-1: 2005
- UL 1577: 2014.

Application Domains

- Industrial.

Absolute maximum ratings

Parameter	Symbol	Unit	Min	Typ	Max	Conditions
Maximum supply voltage (not destructive)	$U_{C\ max}$	V			8	
Maximum supply voltage (not entering non-standard modes)					6.5	
Maximum overload capability	$\hat{I}_{P\ max}$	A			±200	$T_A = 25\ ^\circ\text{C}$, 1 ms pulse
Maximum electrostatic discharge voltage (HMB-Human Body Model)	$U_{ESD\ HBM}$	V			2000	AEC-Q100-002 REV D
Maximum electrostatic discharge voltage (CDM-Charged Device Model)	$U_{ESD\ CDM}$	V			500	AEC-Q100-011 REV B
Maximum output current source	$I_{out\ max}$	mA			25	
Maximum output current sink	$I_{out\ max}$	mA			50	
Maximum junction temperature	$T_{J\ max}$	°C			150	

Insulation coordination

Parameter	Symbol	Unit	Value	Comment
RMS voltage for AC insulation test, 50 Hz, 1 min	U_d	V	3000	According to IEC 60664-1
RMS voltage for AC insulation test, 60 Hz, 1 min	U_d	V	2500	According to UL 1577
RMS voltage for AC insulation test, 50 Hz, 1 min	U_d	V	2400	According to IEC 60950-1
Impulse withstand voltage 1.2/50 μs	\hat{U}_w	V	4000	According to IEC 61800-5-1, IEC 62109-1, UL 60950-1
Partial discharge RMS test voltage ($q_m < 5\ \text{pC}$)	U_t	V	850	Primary/secondary Corresponds to a recurring peak voltage of 728 V peak-to-peak According to IEC 61800-5-1, IEC 62109-1
Clearance (pri. - sec.)	d_{Cl}	mm	7.5	Shortest distance through air
Creepage distance (pri. - sec.)	d_{Cp}			Shortest path along body
Comparative tracking index	CTI		600	
Application example		V	300 V RMS CAT III, PD2	Basic insulation according to IEC 61800-5-1, IEC 62109-1, IEC 60950-1
Application example		V	515 V RMS/ 728 V peak-to-peak CAT II, PD2	Basic insulation according to IEC 61800-5-1 IEC 62109-1, IEC 60950-1

UL 1577 Non Optical isolating devices - Component

File # E486776, Vol 1

Single protection, non-optical isolators, 2500 vac insulation.

Standards

- UL 1577, Optical Isolators;
- CSA Component Acceptance Service Notice N°. 5 A, Component Acceptance Service for Optocouplers and Related Devices.

Marking

Only those products bearing the UL or UR Mark should be considered to be Listed or Recognized and covered under UL's Follow-Up Service. Always look for the Mark on the product.

Environmental and mechanical characteristics

Parameter	Symbol	Unit	Min	Typ	Max	Conditions
Ambient operating temperature	T_A	°C	-40		125	
Ambient storage temperature	T_S	°C	-55		165	
Resistance of the primary @ $T_A = 25\text{ °C}$	R_P	mΩ		0.75		
Thermal resistance, junction to board ¹⁾	$R_{th\text{JB}}$	°K/W		9		
Time constant	t	s		1		To reach steady state

Note: ¹⁾ Done on LEM evaluation board PCB2325.

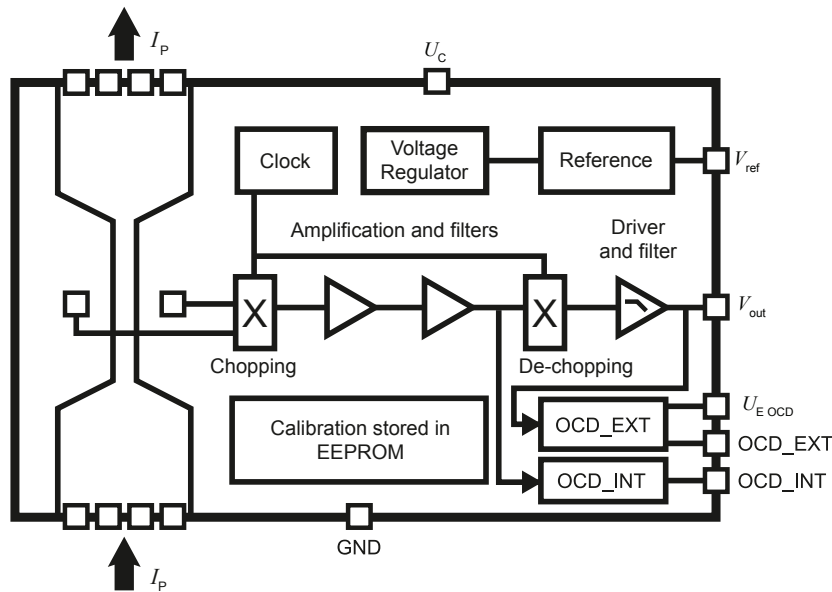
Block diagram

Connection diagram

Pin#	Name	Function
From 1 to 4	I_{p+}	Input of the primary current
From 5 to 8	I_{p-}	Output of the primary current
9	GND	Ground
10	V_{ref}	Reference voltage (output)
11	NC	No connected pin, leave floating
12	V_{out}	Output voltage
13	OCD_EXT	Output of the external over current detection
14	U_C	Supply voltage
15	U_{EOCD}	External OCD voltage
16	OCD_INT	Output of the internal over current detection, factory setting

Electrical data GO 10-SMS/SP3

 At $T_A = -40\text{ °C} \dots 125\text{ °C}$, $U_C = +3.3\text{ V}$, $R_L = 10\text{ k}\Omega$ unless otherwise noted.

Parameter	Symbol	Unit	Min	Typ	Max	Conditions
Primary nominal RMS current	I_{PN}	A		10		
Primary current, measuring range	I_{PM}	A	-25		25	
Supply voltage	U_C	V	3.135	3.3	3.465	
Current consumption	I_C	mA		20	26	
Reference voltage (output)	V_{ref}	V		1.65		@ 25 °C
Reference voltage (input)	V_{ref}	V	0.5		1.7	$U_C = 3.14 \dots 3.46\text{ V}$
Output voltage range @ I_{PM}	$V_{out} - V_{ref}$	V	1.25		1.25	
Output internal resistance	R_{out}	Ω			5	Up to 10 kHz
Reference internal resistance	R_{ref}	Ω	120	200	333	
Capacitive loading	C_L	nF	0		6	
Theoretical sensitivity	G_{th}	mV/A		50		
Electrical offset voltage @ $I_{PN} = 0$	V_{OE}	mV	-5		5	$T_A = 25\text{ °C}$, $V_{out} - V_{ref}$ @ $V_{ref} = 1.65\text{ V}$
Electrical offset current referred to I_{PN}	I_{OE}	mA	-100		100	$T_A = 25\text{ °C}$
Temperature coefficient of V_{ref}	TCV_{ref}	ppm/K	-150		150	$V_{ref} = 1.65\text{ V}$
Temperature coefficient of V_{OE}	TCV_{OE}	mV/K	-0.075		0.075	
Temperature coefficient of I_{OE}	TCI_{OE}	mA/K	-1.5		1.5	
Temperature coefficient of G	TCG	ppm/K	-150		150	
Step response time to 90 % of I_{PN}	t_r	μs			2	
Reaction time @ 10 % of I_{PN}	t_{ra}	μs			1.5	
Frequency bandwidth -3 dB, $T_A = 25\text{ °C}$	BW	KHz		300		
Output noise voltage spectral density	e_{no}	$\mu\text{V}/\text{Hz}^{1/2}$		8		NBW = 1 kHz ... 100 kHz
Internal overcurrent detection (OCD) threshold	I_{IOCD}	A		$2.69 \times I_{PN}$		Factory setting EEPROM
Internal OCD threshold error	ε_{IOCD}	%	-8		8	of peak value
Internal OCD output on resistance	R_{onIOCD}	Ω	70	95	100	open drain output, active low
Internal OCD output hold time	$t_{holdIOCD}$	μs	7	10	14	
Internal OCD response time	t_{rIOCD}	μs	1.4		2.1	
Sensitivity error	ε_G	%	-1		1	Factory adjustment
Linearity error 0 ... I_{PN}	ε_L	% @ I_{PN}	-0.3		0.3	
Linearity error 0 ... I_{PM}	ε_L	% @ I_{PM}	-0.6		0.6	
Accuracy @ I_{PN}	X	% @ I_{PN}	-1.3		1.3	$T_A = 25\text{ °C}$
Accuracy @ I_{PN} @ $T_A = 85\text{ °C}$ ¹⁾	X	% @ I_{PN}	-3.1		3.1	
Accuracy @ I_{PN} @ $T_A = 105\text{ °C}$	X	% @ I_{PN}	-3.7		3.7	
Accuracy @ I_{PN} @ $T_A = 125\text{ °C}$	X	% @ I_{PN}	-4.3		4.3	

 Note: ¹⁾Accuracy G :

$$\varepsilon_{TA} = (\varepsilon_L + \varepsilon_G) + \left(\frac{TCV_{OE}}{I_{PN} \times G} + TCG \times 10^{-6} \right) \times (T_A - 25) \times 100$$

Electrical data GO 20-SMS/SP3

 At $T_A = -40\text{ °C} \dots 125\text{ °C}$, $U_C = +3.3\text{ V}$, $R_L = 10\text{ k}\Omega$ unless otherwise noted.

Parameter	Symbol	Unit	Min	Typ	Max	Conditions
Primary nominal RMS current	I_{PN}	A		20		
Primary current, measuring range	I_{PM}	A	-50		50	
Supply voltage	U_C	V	3.135	3.3	3.465	
Current consumption	I_C	mA		20	26	
Reference voltage (output)	V_{ref}	V		1.65		@ 25 °C
Reference voltage (input)	V_{ref}	V	0.5		1.7	$U_C = 3.14 \dots 3.46\text{ V}$
Output voltage range @ I_{PM}	$V_{out} - V_{ref}$	V	-1.25		1.25	
Output internal resistance	R_{out}	Ω			5	Up to 10 kHz
Reference internal resistance	R_{ref}	Ω	120	200	333	
Capacitive loading	C_L	nF	0		6	
Theoretical sensitivity	G_{th}	mV/A		25		
Electrical offset voltage @ $I_{PN} = 0$	V_{OE}	mV	-5		5	$T_A = 25\text{ °C}$, $V_{out} - V_{ref}$ @ $V_{ref} = 1.65\text{ V}$
Electrical offset current referred to I_{PN}	I_{OE}	mA	-100		100	$T_A = 25\text{ °C}$
Temperature coefficient of V_{ref}	TCV_{ref}	ppm/K	-150		150	$V_{ref} = 1.65\text{ V}$
Temperature coefficient of V_{OE}	TCV_{OE}	mV/K	-0.075		0.075	
Temperature coefficient of I_{OE}	TCI_{OE}	mA/K	-1.5		1.5	
Temperature coefficient of G	TCG	ppm/K	-150		150	
Step response time to 90 % of I_{PN}	t_t	μs			2	
Reaction time @ 10 % of I_{PN}	t_{ra}	μs			1.5	
Frequency bandwidth -3 dB, $T_A = 25\text{ °C}$	BW	KHz		300		
Output noise voltage spectral density	e_{no}	$\mu\text{V}/\text{Hz}^{1/2}$		4.5		NBW = 1 kHz ... 100 kHz
Internal overcurrent detection (OCD) threshold	I_{IOCD}	A		$3.05 \times I_{PN}$		Factory setting EEPROM
Internal OCD threshold error	ε_{IOCD}	%	-8		8	of peak value
Internal OCD output on resistance	R_{onIOCD}	Ω	70	95	100	open drain output, active low
Internal OCD output hold time	$t_{holdIOCD}$	μs	7	10	14	
Internal OCD response time	t_{rIOCD}	μs	1.4		2.1	
Sensitivity error	ε_G	%	-1		1	Factory adjustment
Linearity error 0 ... I_{PN}	ε_L	% @ I_{PN}	-0.3		0.3	
Linearity error 0 ... I_{PM}	ε_L	% @ I_{PM}	-0.6		0.6	
Accuracy @ I_{PN}	X	% @ I_{PN}	-1.3		1.3	$T_A = 25\text{ °C}$
Accuracy @ I_{PN} @ $T_A = 85\text{ °C}$ ¹⁾	X	% @ I_{PN}	-3.1		3.1	
Accuracy @ I_{PN} @ $T_A = 105\text{ °C}$	X	% @ I_{PN}	-3.7		3.7	
Accuracy @ I_{PN} @ $T_A = 125\text{ °C}$	X	% @ I_{PN}	-4.3		4.3	

 Note: ¹⁾ Accuracy G :

$$\varepsilon_{TA} = (\varepsilon_L + \varepsilon_G) + \left(\frac{TCV_{OE}}{I_{PN} \times G} + TCG \times 10^{-6} \right) \times (T_A - 25) \times 100$$

Electrical data GO 30-SMS/SP3

 At $T_A = -40\text{ °C} \dots 125\text{ °C}$, $U_C = +3.3\text{ V}$, $R_L = 10\text{ k}\Omega$ unless otherwise noted.

Parameter	Symbol	Unit	Min	Typ	Max	Conditions
Primary nominal RMS current	I_{PN}	A		30		
Primary current, measuring range	I_{PM}	A	-75		75	
Supply voltage	U_C	V	3.135	3.3	3.465	
Current consumption	I_C	mA		20	26	
Reference voltage (output)	V_{ref}	V		1.65		@ 25 °C
Reference voltage (input)	V_{ref}	V	0.5		1.7	$U_C = 3.14 \dots 3.46\text{ V}$
Output voltage range @ I_{PM}	$V_{out} - V_{ref}$	V	-1.25		1.25	
Output internal resistance	R_{out}	Ω			5	Up to 10 kHz
Reference internal resistance	R_{ref}	Ω	120	200	333	
Capacitive loading	C_L	nF	0		6	
Theoretical sensitivity	G_{th}	mV/A		16.7		
Electrical offset voltage @ $I_{PN} = 0$	V_{OE}	mV	-5		5	$T_A = 25\text{ °C}$, $V_{out} - V_{ref}$ @ $V_{ref} = 1.65\text{ V}$
Electrical offset current referred to I_{PN}	I_{OE}	mA	-100		100	$T_A = 25\text{ °C}$
Temperature coefficient of V_{ref}	TCV_{ref}	ppm/K	-150		150	$V_{ref} = 1.65\text{ V}$
Temperature coefficient of V_{OE}	TCV_{OE}	mV/K	-0.075		0.075	
Temperature coefficient of I_{OE}	TCI_{OE}	mA/K	-1.5		1.5	
Temperature coefficient of G	TCG	ppm/K	-150		150	
Step response time to 90 % of I_{PN}	t_r	μs			2	
Reaction time @ 10 % of I_{PN}	t_{ra}	μs			1.5	
Frequency bandwidth -3 dB, $T_A = 25\text{ °C}$	BW	KHz		300		
Output noise voltage spectral density	e_{no}	$\mu\text{V}/\text{Hz}^{1/2}$		4.5		NBW = 1 kHz ... 100 kHz
Internal overcurrent detection (OCD) threshold	I_{IOCD}	A		$3.05 \times I_{PN}$		Factory setting EEPROM
Internal OCD threshold error	ε_{IOCD}	%	-8		8	of peak value
Internal OCD output on resistance	R_{onIOCD}	Ω	70	95	100	open drain output, active low
Internal OCD output hold time	$t_{holdIOCD}$	μs	7	10	14	
Internal OCD response time	t_{rIOCD}	μs	1.4		2.1	
Sensitivity error	ε_G	%	-1		1	Factory adjustment
Linearity error 0 ... I_{PN}	ε_L	% @ I_{PN}	-0.3		0.3	
Linearity error 0 ... I_{PM}	ε_L	% @ I_{PM}	-0.6		0.6	
Accuracy @ I_{PN}	X	% @ I_{PN}	-1.3		1.3	$T_A = 25\text{ °C}$
Accuracy @ I_{PN} @ $T_A = 85\text{ °C}$ ¹⁾	X	% @ I_{PN}	-3.1		3.1	
Accuracy @ I_{PN} @ $T_A = 105\text{ °C}$	X	% @ I_{PN}	-3.7		3.7	
Accuracy @ I_{PN} @ $T_A = 125\text{ °C}$	X	% @ I_{PN}	-4.3		4.3	

Note: ¹⁾ Accuracy G :

$$\varepsilon_{TA} = (\varepsilon_L + \varepsilon_G) + \left(\frac{TCV_{OE}}{I_{PN} \times G} + TCG \times 10^{-6} \right) \times (T_A - 25) \times 100$$

External overcurrent detection

Parameter	Symbol	Unit	Specification			Conditions
			Min	Typical	Max	
External OCD voltage	$U_{E\text{OCD}}$	V	0.3		1.2	
External OCD output on resistance to ground	$R_{\text{onE OCD}}$	Ω	35	200	300	
External OCD response time	$t_{r\text{E OCD}}$	μs		10		To be added to the transducer response time
External OCD output hold time	$t_{\text{hold E OCD}}$	μs		10		
External OCD threshold error	$\varepsilon_{\text{E OCD}}$	%		± 5		Switch point error between V_{out} and $U_{\text{E OCD}}$

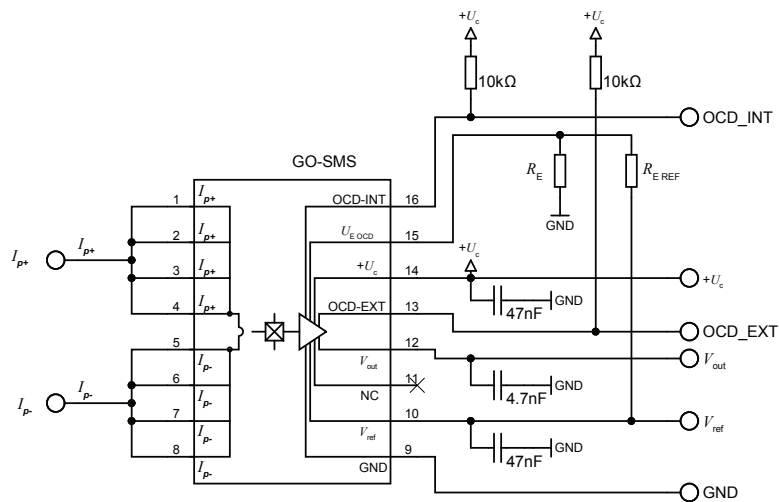
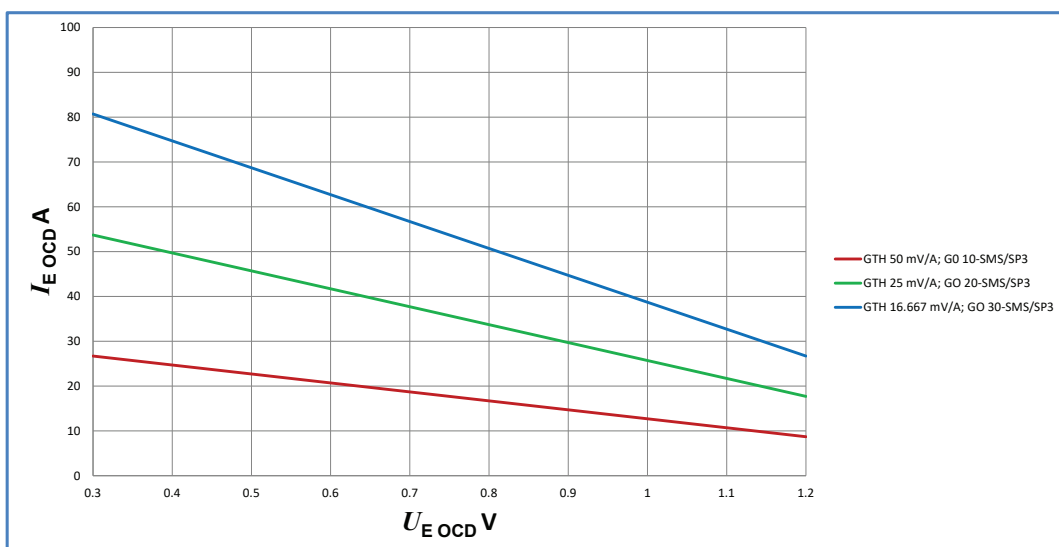

 $I_{E\text{OCD}}$: External overcurrent detection (OCD threshold)

$$I_{E\text{OCD}} = \frac{(V_{\text{ref}} - U_{E\text{OCD}})}{G_{\text{Th}}} \times 1000 \quad U_{E\text{OCD}} = \frac{R_E}{R_E + R_{\text{ref}}} \times V_{\text{ref}}$$

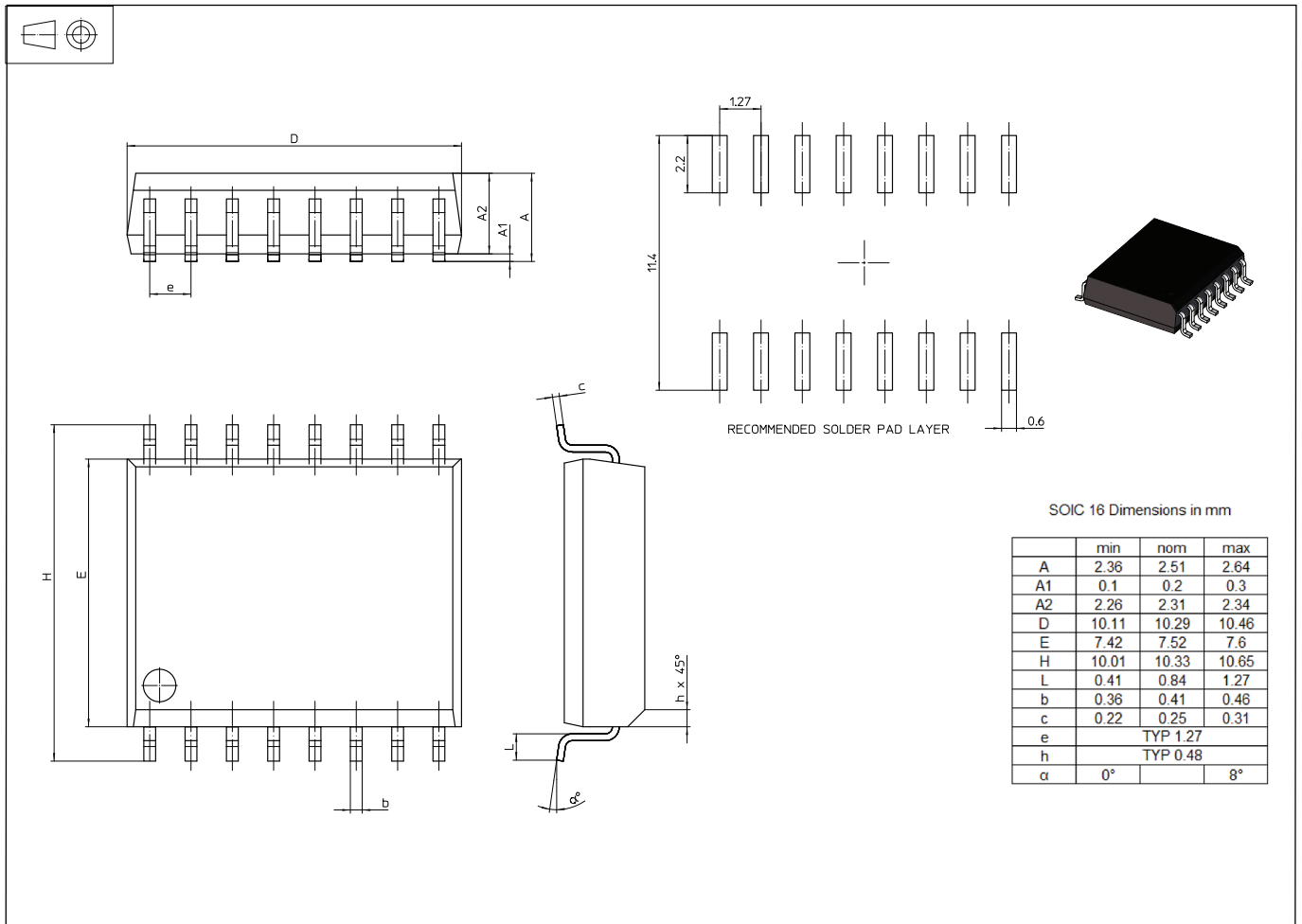
Dimensions (in mm)

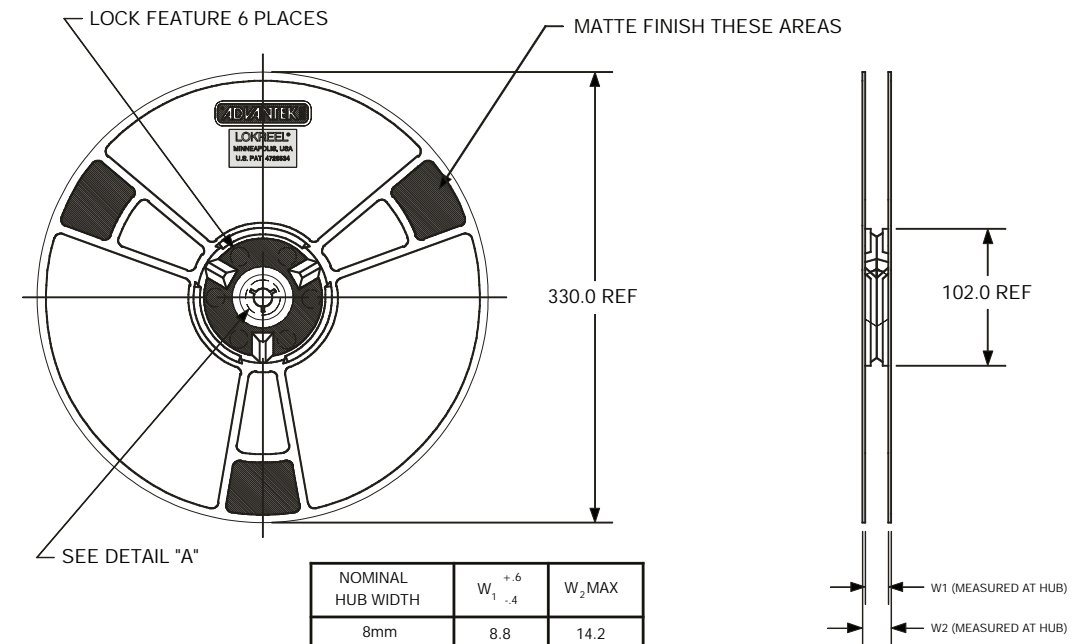

Tape and reel dimensions (in mm)



NOMINAL HUB WIDTH	$W_1 \begin{smallmatrix} +.6 \\ -.4 \end{smallmatrix}$	$W_2 \text{ MAX}$
8mm	8.8	14.2
12mm	12.8	18.2
16mm	16.8	22.2
24mm	24.8	30.2
32mm	32.8	38.2
44mm	44.8	50.2
56mm	56.8	62.2

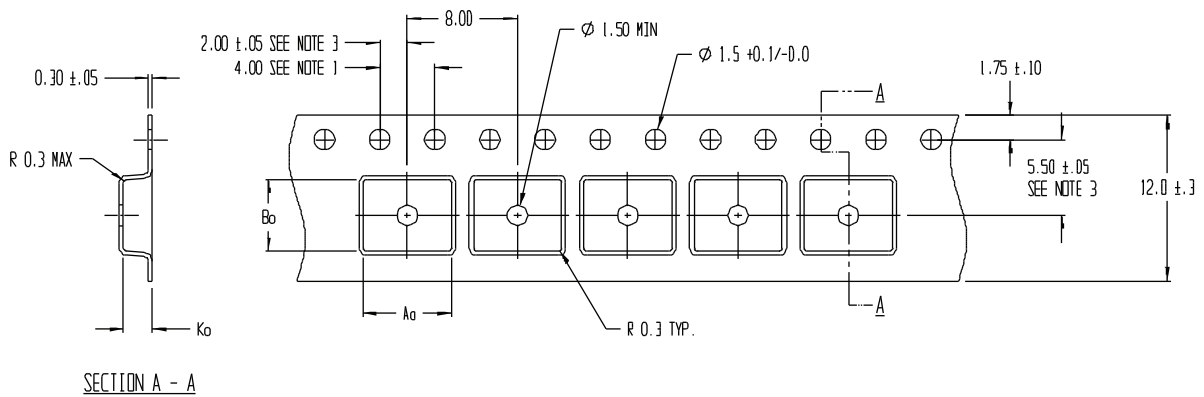
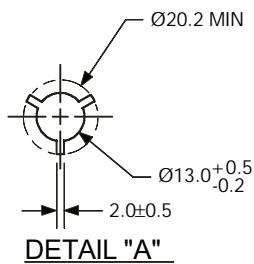

- Notes:
- 1) 10 Sprocket hole pitch cumulative tolerance ± 0.2 mm
 - 2) Camber in compliance with EIA 481
 - 3) Pocket position relative to sprocket hole measured as true position of pocket, not pocket hole.

Soldering requirements

MSL3, 260 °C - IPC/JEDEC J-STD-020

Ordering information

Item number	Description	Package type	Package quantity
G2.07.13.003.0	GO 10-SMS/SP3	Reel	1500
G2.07.13.103.0	GO 10-SMS/SP3 KIT 5P	Blister	5
G2.07.13.303.0	GO 10-SMS/SP3 SET OF 50 PCS	SMD Bag	50
G2.07.17.003.0	GO 20-SMS/SP3	Reel	1500
G2.07.17.103.0	GO 20-SMS/SP3 KIT 5P	Blister	5
G2.07.17.303.0	GO 20-SMS/SP3 SET OF 50 PCS	SMD Bag	50
G2.07.20.003.0	GO 30-SMS/SP3	Reel	1500
G2.07.20.103.0	GO 30-SMS/SP3 KIT 5P	Blister	5
G2.07.20.303.0	GO 30-SMS/SP3 SET OF 50 PCS	SMD Bag	50