

AUTOMOTIVE CURRENT TRANSDUCER OPEN LOOP TECHNOLOGY

HAH1BVW S/15



Introduction

The HAH1BVW family is for the electronic measurement of DC, AC or pulsed currents in high power and low voltage automotive applications with galvanic separation between the primary circuit (high power) and the secondary circuit (electronic circuit).

The HAH1BVW family gives you the choice of having different current measuring ranges in the same housing.

Features

- Ratiometric transducer
- Open Loop transducer using the Hall effect
- Low voltage application
- Unipolar +5 V DC power supply
- Primary current measuring range ± 1500 A
- Maximum RMS primary admissible current: defined by busbar to have $T < +150$ °C
- Operating temperature range: -40 °C $< T < 125$ °C
- Output voltage: full ratio-metric (in sensitivity and offset).

Advantages

- Excellent accuracy
- Very good linearity
- Very low thermal offset drift
- Very low thermal sensitivity drift
- Galvanic separation
- Non intrusive solution.

Automotive application

- Battery Management.

Principle of HAH1BVW Family

The open loop transducers uses a Hall effect integrated circuit. The magnetic flux density B , contributing to the rise of the Hall voltage, is generated by the primary current I_p to be measured. The current to be measured I_p is supplied by a current source i.e. battery or generator (Figure 1). Within the linear region of the hysteresis cycle, B is proportional to:

$$B(I_p) = a \times I_p$$

The Hall voltage is thus expressed by:

$$U_{Hall} = (c_{Hall} / d) \times I_{Hall} \times a \times I_p$$

Except for I_p , all terms of this equation are constant. Therefore:

$$U_{Hall} = b \times I_p$$

a constant

b constant

c_{Hall} Hall coefficient

d thickness of the Hall plate

I_{Hall} current across the Hall plates

The measurement signal U_{Hall} amplified to supply the user output voltage or current.

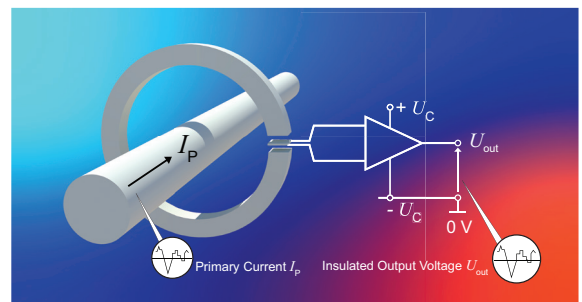
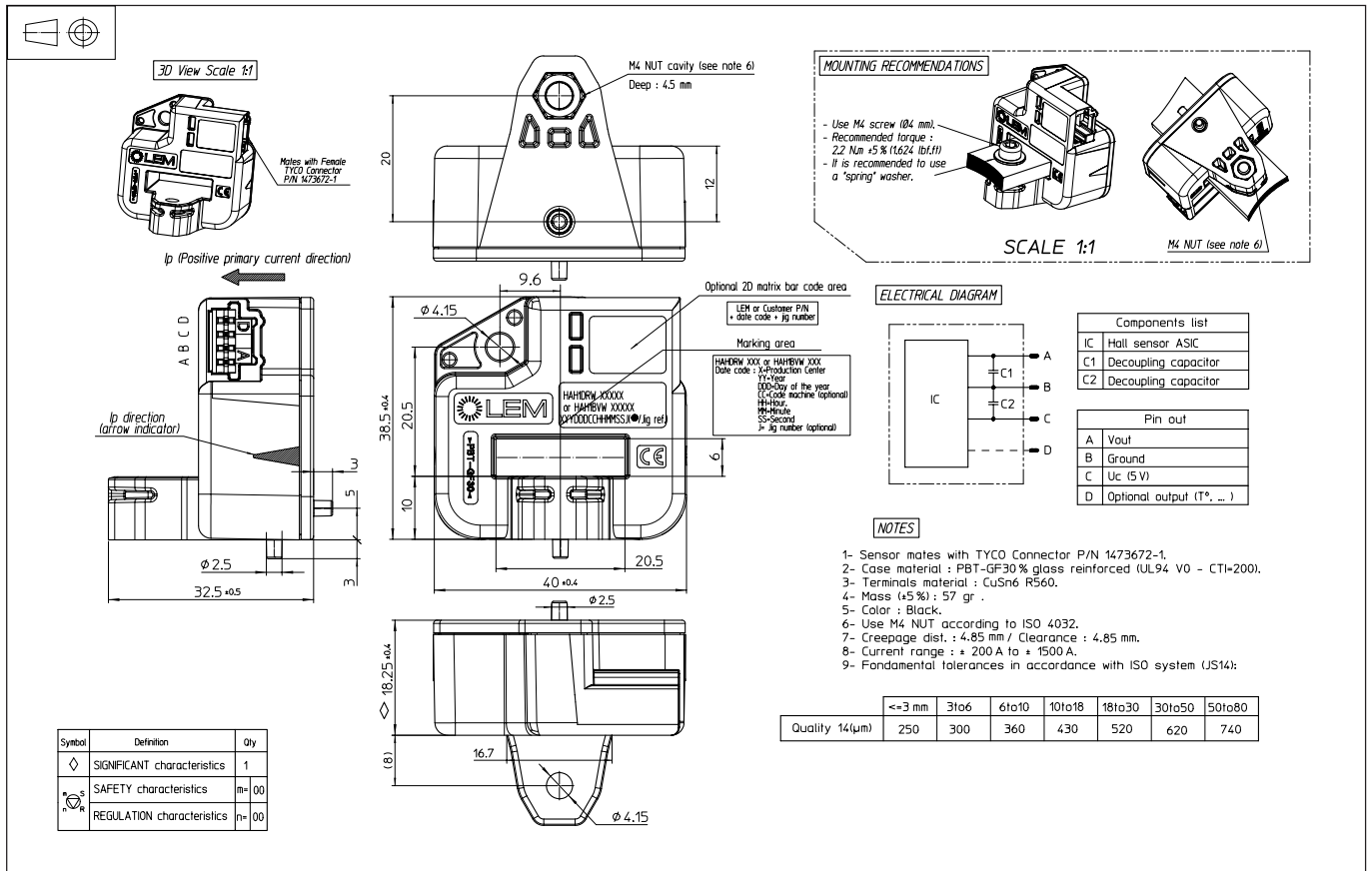

Fig. 1: Principle of the open loop transducer.

Dimensions (in mm)



Mechanical characteristics

- Plastic case PBT GF 30
- Magnetic core FeSi alloy
- Mass 57 g $\pm 5\%$
- Pins Brass tin plated
- IP level IPx 2.

Mounting recommendation

- Mating connector type TYCO connector P/N 1473672-1
- Assembly torque max 2.2 N·m $\pm 5\%$
- Soldering type N/A.

Electronic schematic

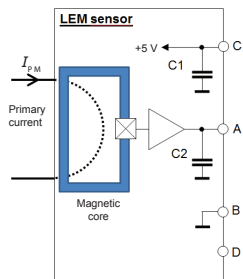

Components list		
IC	Hall sensor ASIC	
C1	Decoupling capacitor	100 nF
C2	EMC protection capacitor	68 nF

Pin out	
A	U _{out}
B	GND
C	U _c (5 V)
D	not connected

Remark

- $U_{out} > U_o$ when I_p flows in the positive direction (see arrow on drawing).

System architecture (example)

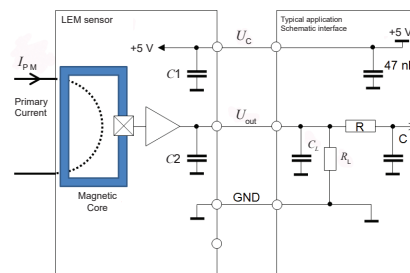

- $C_c < 100$ nF EMC protection (optional)
- RC Low pass filter (optional)

On board diagnostic

- $R_L > 10$ k Ω . Resistor for signal line diagnostic (optional)

U _{out}	Diagnostic
Open circuit	$U_{IN} \leq 0.15$ V
Short GND	$U_{IN} \leq 0.15$ V

Absolute ratings (not operating)

Parameter	Symbol	Unit	Specification			Conditions
			Min	Typical	Max	
Maximum supply voltage	$U_{C\max}$	V			14	
Maximum reverse supply voltage	$U_{C\max}$	V	-14			
Maximum output voltage	$U_{out\max}$	V	-14		14	U_{out} Reverse / Forward voltage
Maximum output current	$I_{out\max}$	mA	-10		10	
Ambient storage temperature	T_{Ast}	°C	-40		125	
Electrostatic discharge voltage (HBM)	$U_{ESD\ HBM}$	kV			8	
Maximum admissible vibration (random RMS)	γ_{\max}	m·s ⁻²			27.1	10 to 1000 Hz, -40 °C to 125 °C
RMS voltage for AC insulation test	U_d	kV			2.5	50 Hz, 1 min
Creepage distance	d_{Cp}	mm	4.85			
Clearance	d_{Cl}	mm	4.85			
Comparative tracking index	CTI		PLC 3			

Operating characteristics in nominal range (I_{PN})

Parameter	Symbol	Unit	Specification			Conditions
			Min	Typical	Max	
Electrical Data						
Primary current, measuring range	I_{PM}	A	-1500		1500	
Primary nominal RMS current	I_{PN}	A	-1500		1500	
Supply voltage	U_C	V	4.5	5	5.5	
Ambient operating temperature	T_A	°C	-40		125	
Output voltage	U_{out}	V	$U_{out} = (U_C / 5) \times (U_o + S \times I_p)$			
Sensitivity	S	mV/A		1.333		@ $T_A = 25\text{ °C}$
Offset voltage	U_o	V		2.5		
Output resolution		mV		2.5		
Output clamping high voltage	U_{SZ}		4.7	4.75	4.8	@ $U_C = 5\text{ V}$
Output clamping low voltage	U_{SZ}		0.2	0.25	0.3	@ $U_C = 5\text{ V}$
Current consumption	I_C	mA		7	10	@ $T_A = 25\text{ °C}$, @ $U_C = 5\text{ V}$
Load resistance	R_L	KΩ	10			
Output internal resistance	R_{out}	Ω		1	10	@ $T_A = 25\text{ °C}$
Performance Data						
Ratiometricity error	ϵ_r	%		±0.2		
Sensitivity error	ϵ_s	%		±2		@ $T_A = 25\text{ °C}$, @ $U_C = 5\text{ V}$
Electrical offset voltage	U_{OE}	mV		±3		@ $T_A = 25\text{ °C}$, @ $U_C = 5\text{ V}$
Magnetic offset voltage @ $I_p = 0\text{ V}$	U_{OM}	mV		±2		@ $U_C = 5\text{ V}$, @ $T_A = 25\text{ °C}$
Linearity error	ϵ_L	%	-1		1	% of full scale
Average temperature coefficient of U_{OE}	$TCU_{OE\ AV}$	mV/°C		±0.06		@ $U_C = 5\text{ V}$
Average temperature coefficient of S	TCS_{AV}	%/°C		±0.02		
Delay time to 90 % to the final output value for I_{PN} step	t_{D90}	ms			10	
Frequency bandwidth	BW	Hz		70		@ -3 dB
Peak-to-peak noise voltage	$U_{no\ pp}$	mV			10	DC to 1 MHz
Output RMS noise voltage	U_{no}	mV			1.6	
Start-up time	t_{start}	ms			1	
Settling time	t_s	ms			10	

Total error ϵ_{tot}

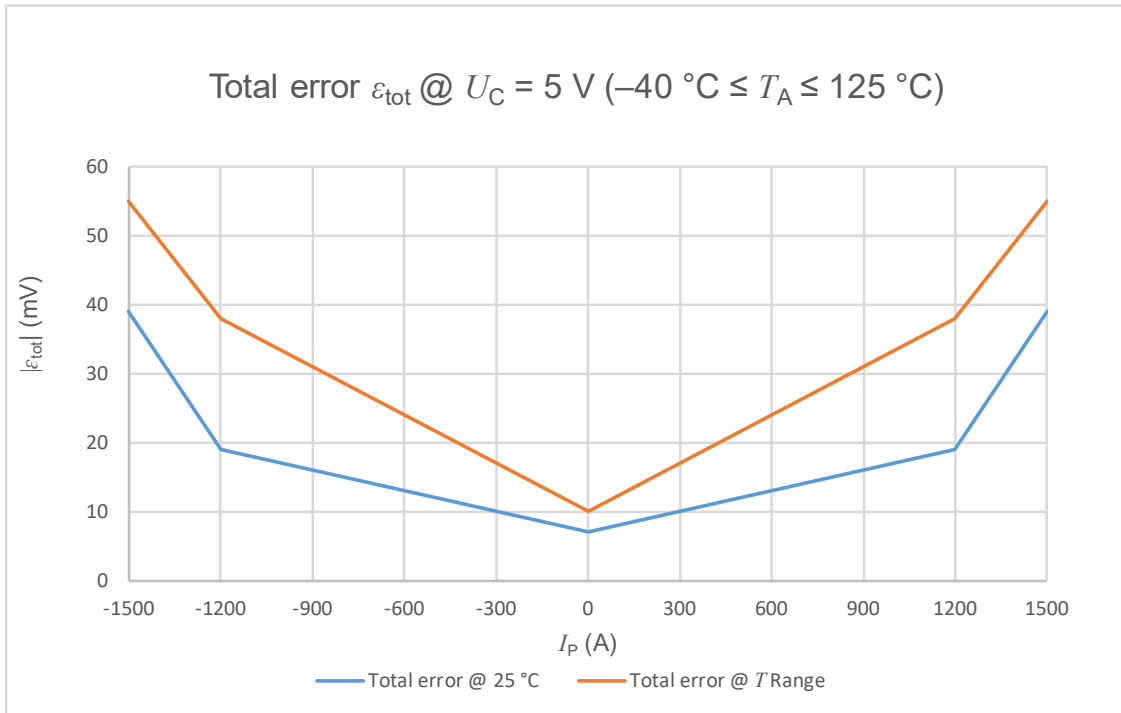

Total error ϵ_{tot} specification. Max value @ $\pm 3\delta$						
I_P (A)	Typical values $T_A = 25\text{ °C}, U_C = 5\text{ V}$			Maximum values $-40\text{ °C} \leq T_A \leq 125\text{ °C}, U_C = 5\text{ V}$		
	1500	39 mV	29.26 A	1.95 %	55 mV	41.26 A
1200	19 mV	14.25 A	0.95 %	38 mV	28.51 A	1.90 %
0	7 mV	5.25 A	0.35 %	10 mV	7.5 A	0.50 %
-1200	19 mV	14.25 A	0.95 %	38 mV	28.51 A	1.90 %
-1500	39 mV	29.26 A	1.95 %	55 mV	41.26 A	2.75 %

PERFORMANCES PARAMETERS DEFINITIONS

Primary current definition:

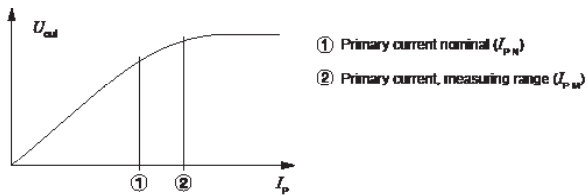

Definition of typical, minimum and maximum values:

Minimum and maximum values for specified limiting and safety conditions have to be understood as such as values shown in “typical” graphs. On the other hand, measured values are part of a statistical distribution that can be specified by an interval with upper and lower limits and a probability for measured values to lie within this interval. Unless otherwise stated (e.g. “100 % tested”), the LEM definition for such intervals designated with “min” and “max” is that the probability for values of samples to lie in this interval is 99.73 %. For a normal (Gaussian) distribution, this corresponds to an interval between -3 sigma and +3 sigma. If “typical” values are not obviously mean or average values, those values are defined to delimit intervals with a probability of 68.27 %, corresponding to an interval between -sigma and +sigma for a normal distribution. Typical, minimum and maximum values are determined during the initial characterization of a product.

Output noise voltage:

The output voltage noise is the result of the noise floor of the Hall elements and the linear amplifier.

Magnetic offset:

The magnetic offset is the consequence of an any current on the primary side. It's defined after a stated excursion of primary current.

Linearity:

The maximum positive or negative discrepancy with a reference straight line $U_{out} = f(I_p)$.
 Unit: linearity (%) expressed with full scale of I_{pN} .

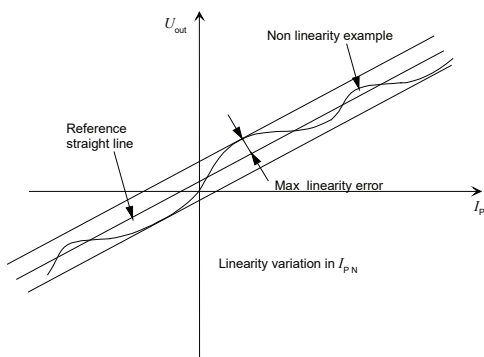

Delay time $t_{D 90\%}$:

The time between the primary current signal (I_{pN}) and the output signal reach at 90 % of its final value.

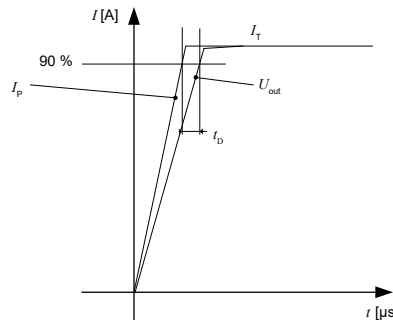

Sensitivity:

The transducer's sensitivity S is the slope of the straight line

$U_{out} = f(I_p)$, it must establish the relation:

$$U_{out}(I_p) = U_C / 5 (S \times I_p + U_O)$$

Offset with temperature:

The error of the offset in the operating temperature is the variation of the offset in the temperature considered with the initial offset at 25 °C.

The offset variation I_{OT} is a maximum variation the offset in the temperature range:

$$I_{OT} = I_{OE \max} - I_{OE \min}$$

The offset drift $TCI_{OE \text{ AV}}$ is the I_{OT} value divided by the temperature range.

Sensitivity with temperature:

The error of the sensitivity in the operating temperature is the relative variation of sensitivity with the temperature considered with the initial offset at 25 °C.

The sensitivity variation S_T is the maximum variation (in ppm or %) of the sensitivity in the temperature range:
 $S_T = (\text{Sensitivity max} - \text{Sensitivity min}) / \text{Sensitivity at } 25 \text{ }^\circ\text{C}$.

The sensitivity drift TCS_{AV} is the S_T value divided by the temperature range. Deeper and detailed info available is our LEM technical sales offices (www.lem.com).

Offset voltage @ $I_p = 0 \text{ A}$:

The offset voltage is the output voltage when the primary current is zero. The ideal value of U_O is $U_C / 2$. So, the difference of $U_O - U_C / 2$ is called the total offset voltage error. This offset error can be attributed to the electrical offset (due to the resolution of the ASIC quiescent voltage trimming), the magnetic offset, the thermal drift and the thermal hysteresis. Deeper and detailed info available is our LEM technical sales offices (www.lem.com).

Environmental test specifications:

Refer to LEM GROUP test plan laboratory CO.11.11.515.0 with “Tracking_Test Plan_Auto” sheet.

Environmental test specifications:

Refer to LEM GROUP test plan laboratory CO.11.11.515.0 with "Tracking_Test Plan_Auto" sheet.

Name	Standard
CHARACTERIZATION @ 25 °C	
Sensitivity / Accuracy / Total error	LEM 98.20.00.574.0
Offset / Electrical Offset / Magnetic Offset	LEM 98.20.00.573.0
Linearity error	LEM 98.20.00.370.0
Current Consumption	LEM 98.20.00.579.0
CHARACTERIZATION WITH T °C (initial)	
Sensitivity / Accuracy / Total error	LEM 98.20.00.574.0
T °C variation of ... / Temperature Coefficient of S	LEM 98.20.00.574.0
Offset / Electrical Offset / Magnetic Offset	LEM 98.20.00.573.0
T °C variation of ... / Temperature Coefficient of Offset	LEM 98.20.00.573.0
Linearity error	LEM 98.20.00.370.0
Current Consumption	LEM 98.20.00.579.0
ELECTRICAL TESTS @ 25 °C	
Dielectric withstand Voltage test	2500 V AC / 1 min / 50 Hz
Insulation resistance test	500 V DC, time = 60 s $R_{INS} \geq 500$ M Ω Minimum
ENVIRONMENTAL TESTS (CLIMATIC)	
Thermal shock	ISO 16750-4 § 5.3.2 (04/2010) 500 cycles (500 hours), 30 min @ -40 °C // 30 min @ +125 °C U_C not connected, $I_p = 0$
Steady state T °C Humidity bias life test	JESD 22-A101 (03/2009)
MECHANICAL TESTS	
Vibration random in T °C	ISO 16750-3 § 4.1.2.4(12/2012) 27.1 m/s ² , 8 h/axe 10 Hz -1000 Hz
Shocks	ISO 16750-3 § 4.2.2 (12/2012) 50 g/ 6 ms Half Sine @ 25 °C 10 shocks of each direction (Total: 60) U_C not connected, $I_p = 0$
Free Fall (Device not packaged)	IEC 60068-2-31 §5.2: method 1 (05/2008)
FINAL CHARACTERIZATION	
Characterization @ 25 °C	
Characterization with temperature	

IMPORTANT NOTICE

The information in this document is considered accurate and reliable. However, LEM International SA and any company directly or indirectly controlled by LEM Holding SA ("LEM") do not provide any guarantee or warranty, expressed or implied, regarding the accuracy or completeness of this information and are not liable for any consequences resulting from its use. LEM shall not be responsible for any indirect, incidental, punitive, special, or consequential damages (including, but not limited to, lost profits, lost savings, business interruption, costs related to the removal or replacement of products, or rework charges) regardless of whether such damages arise from tort (including negligence), warranty, breach of contract, or any other legal theory.

LEM reserves the right to update the information in this document, including specifications and product descriptions, at any time without prior notice. Information in this document replaces any previous versions of this document. No license to any intellectual property is granted by LEM through this document, either explicitly or implicitly. Any Information and product described herein is subject to export control regulations.

LEM products may possess either unidentified or documented vulnerabilities. It is the sole responsibility of the purchaser to design and operate their applications and products in a manner that mitigates the impact of these vulnerabilities. LEM disclaims any liability for such vulnerabilities. Customers must select products with security features that best comply with applicable rules, regulations, and standards for their intended use. The purchaser is responsible for making final design decisions regarding its products and for ensuring compliance with all legal, regulatory, and security-related requirements, irrespective of any information or support provided by LEM.

LEM products are not intended, authorized, or warranted for use in life support, life-critical, or safety-critical systems or equipment, nor in applications where failure or malfunction of an LEM product could result in personal injury, death, or significant property or environmental damage. LEM and its suppliers do not assume liability for the inclusion and/or use of LEM products in such equipment or applications; thus, this inclusion and/or use is at the purchaser's own and sole risk. Unless explicitly stated that a specific LEM product is automotive qualified, it should not be used in automotive applications. LEM does not accept liability for the inclusion and/or use of non-automotive qualified products in automotive equipment or applications.

Applications that are described herein are for illustrative purposes only. LEM makes no representation or warranty that LEM products will be suitable for a particular purpose, a specified use or application. The purchaser is solely responsible for the design and operation of its applications and devices using LEM products, and LEM accepts no liability for any assistance with any application or purchaser product design. It is purchaser's sole responsibility to determine whether the LEM product is suitable and fit for the purchaser's applications and products planned, as well as for the planned application and use of purchaser's third-party customer(s).

Stressing and using LEM products at or above limiting values will cause permanent damage to the LEM product and potentially to any device embedding or operating with LEM product. Limiting values are stress ratings only and operation of the LEM product at or above conditions and limits given in this document is not warranted. Continuous or repeated exposure to limiting values will permanently and irreversibly affect the quality and reliability of the LEM product.

LEM products are sold subject to the general terms and conditions of commercial sale, as published at www.lem.com unless otherwise agreed in a specific written agreement. LEM hereby expressly rejects the purchaser's general terms and conditions for purchasing LEM products by purchaser. Any terms and conditions contained in any document issued by the purchaser either before or after issuance of any document by LEM containing or referring to the general terms and conditions of sale are explicitly rejected and disregarded by LEM, and the document issued by the purchaser is wholly inapplicable to any sale or licensing made by LEM and is not binding in any way on LEM.

© 2025 LEM INTERNATIONAL SA – All rights reserved