

AUTOMOTIVE CURRENT TRANSDUCER OPEN LOOP TECHNOLOGY

HAH1DRW 1500-S



Introduction

The HAH1DRW family is for the electronic measurement of DC, AC or pulsed currents in high power and low voltage automotive applications with galvanic separation between the primary circuit (high power) and the secondary circuit (electronic circuit).

The HAH1DRW family gives you the choice of having different current measuring ranges in the same housing.

Features

- Ratiometric transducer
- Open Loop transducer using the Hall effect
- Low voltage application
- Unipolar +5 V DC power supply
- Primary current measuring range ± 1500 A
- Maximum RMS primary admissible current: defined by busbar to have $T < +150$ °C
- Operating temperature range: -40 °C $< T < +125$ °C
- Output voltage: full ratiometric (in sensitivity and offset).

Advantages

- Excellent accuracy
- Very good linearity
- Very low thermal offset drift
- Very low thermal sensitivity drift
- Galvanic separation
- High frequency bandwidth
- Non intrusive solution.

Automotive applications

- Electrical Power Steering
- Starter Generators
- Converters
- Battery Management
- Motor drive application.

Principle of HAH1DRW family

The open loop transducers uses a Hall effect integrated circuit. The magnetic flux density B , contributing to the rise of the Hall voltage, is generated by the primary current I_p to be measured. The current to be measured I_p is supplied by a current source i.e. battery or generator (Figure 1). Within the linear region of the hysteresis cycle, B is proportional to:

$$B(I_p) = a \times I_p$$

The Hall voltage is thus expressed by:

$$U_H = (c_H / d) \times I_H \times a \times I_p$$

Except for I_p , all terms of this equation are constant. Therefore:

$$U_H = b \times I_p$$

a constant

b constant

c_H Hall coefficient

d thickness of the Hall plate

I_H current across the Hall plates

The measurement signal U_H amplified to supply the user output voltage or current.

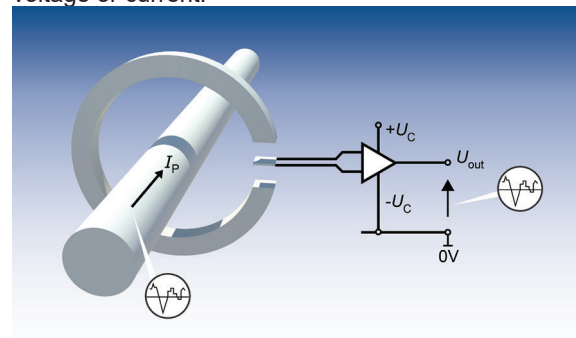
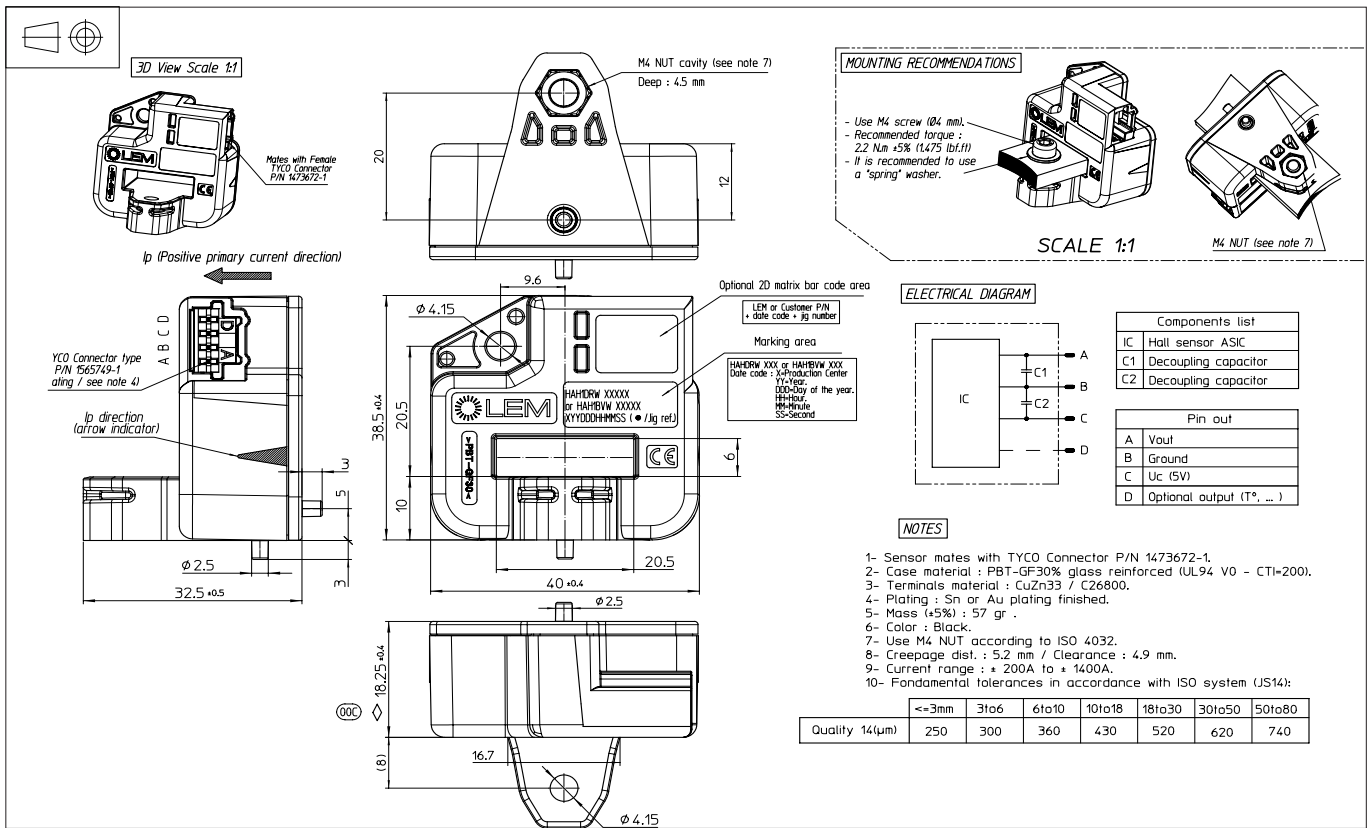

Fig. 1: Principle of the open loop transducer.

Dimensions (in mm)



Mechanical characteristics

- Plastic case PBT GF30
- Magnetic core FeSi wound core
- Mass 57 g \pm 5 %
- Electrical terminal coating Brass tin plated
- IP Code IPx2

Mounting recommendation

- Connector type TYCO connector P/N 1473672-1
- Assembly torque max 2.2 N·m \pm 5 %
- Soldering type N/A

Electronic schematic

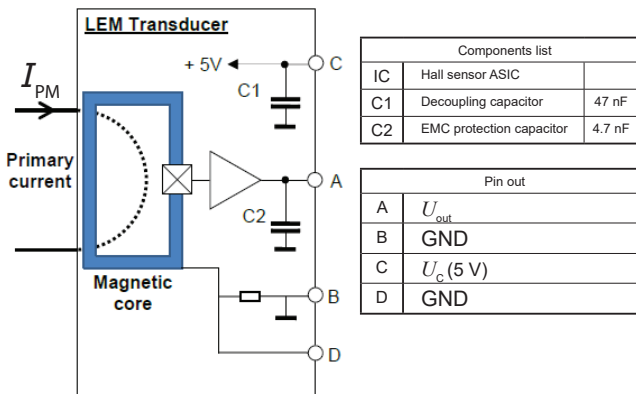

Remark

- $U_{out} > U_0$ when I_p flows in the positive direction (see arrow on drawing).

On board diagnostic

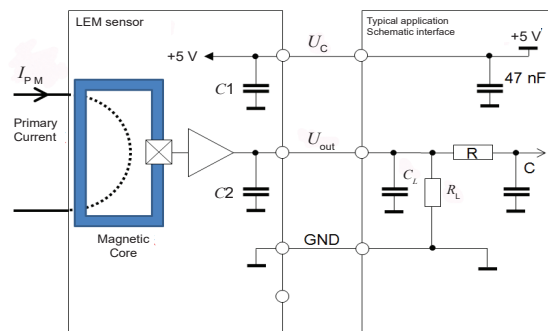

- $C_L < 2.2$ nF EMC protection (optional)
- RC Low pass filter (optional)
- $R_L > 10$ k Ω . Resistor for signal line diagnostic (optional)

U_{out}	Diagnostic
Open circuit	$U_{IN} = U_c$
Short GND	$U_{IN} = 0$ V

Absolute ratings (not operating)

Parameter	Symbol	Unit	Specification			Conditions
			Min	Typical	Max	
Maximum supply voltage	$U_{C\max}$	V	-0.5		8	
Ambient storage temperature	T_S	°C	-40		125	
Electrostatic discharge voltage (HBM)	$U_{ESD\ HBM}$	V			8	
Maximum admissible vibration (random RMS)	γ_{\max}	m·s ⁻²			96.6	10 to 2000 Hz, -40 °C to 125 °C
RMS voltage for AC insulation test, 50 Hz, 1 min	U_d	V			2.5	50 Hz, 1 min
Creepage distance	d_{Cp}	mm	5.2			
Clearance	d_{Cl}	mm	4.9			
Comparative tracking index	CTI			PLC3		
Maximum output current	$I_{out\max}$	mA	-10		10	
Maximum output voltage (Analog)	$U_{out\max}$	V	-0.5		$U_C + 0.5$	
Maximum reverse current	$I_{R\max}$	mA			80	

Operating characteristics in nominal range (I_{PN})

Parameter	Symbol	Unit	Specification			Conditions
			Min	Typical	Max	
Electrical Data						
Primary current, measuring range	I_{PM}	A	-1500		1500	
Primary nominal RMS current	I_{PN}	A	-1500		1500	
Supply voltage ¹⁾	U_C	V	4.75	5	5.25	
Ambient operating temperature	T_A	°C	-40		125	
Output voltage (Analog)	U_{out}	V	$U_{out} = (U_C/5) \times (U_O + S \times I_P)$			
Sensitivity	S	V/A		0.00133		@ $T_A = 25\text{ °C}$
Offset voltage	U_O	V		2.5		
Current consumption	I_C	mA		20	25	
Load resistance	R_L	KΩ	10			
Output internal resistance	R_{out}	Ω		1	10	
Performance Data ¹⁾						
Ratiometricity error	ε_r	%		±0.5		
Sensitivity error	ε_s	%		±0.9		@ $T_A = 25\text{ °C}$, @ $U_C = 5\text{ V}$
Electrical offset current or voltage	I_{OE}	mA		2706		@ $T_A = 25\text{ °C}$, @ $U_C = 5\text{ V}$
	U_{OE}	mV		±3.6		
Magnetic offset current or voltage	I_{OM}	mA		1503		@ $T_A = 25\text{ °C}$, @ $U_C = 5\text{ V}$
	U_{OM}	mV		±2		
Average temperature coefficient of I_{OE}	TCI_{OEAV}	mA/°C		±30		@ $U_C = 5\text{ V}$
Average temperature coefficient of U_{OE}	TCU_{OEAV}	mV/°C		±0.04		@ $U_C = 5\text{ V}$
Linearity error	ε_L	% I_P	-1		+1	
Delay time to 90 % I_{PN}	t_{D90}	μs		2	6	$di/dt = 100\text{ A} / \mu\text{s}$
Frequency bandwidth ²⁾	BW	kHz	40			@ -3 dB
Peak-to-peak noise voltage	$U_{no\ pp}$	mV			14	DC to 1MHz
Output RMS noise voltage	U_{no}	mV			2.2	
Phase shift	$\Delta\varphi$	°	-4			DC to 1MHz

Notes: ¹⁾ The output voltage U_{out} is fully ratiometric. The offset and sensitivity are dependent on the supply voltage U_C relative to the following formula:

$$I_P = \left(\frac{5}{U_C} \times U_{out} - U_O \right) \times \frac{1}{S} \text{ with } S \text{ in (V/A)}$$

²⁾ Primary current frequencies must be limited in order to avoid excessive heating of the busbar, magnetic core and the ASIC (see feature paragraph in page 1).

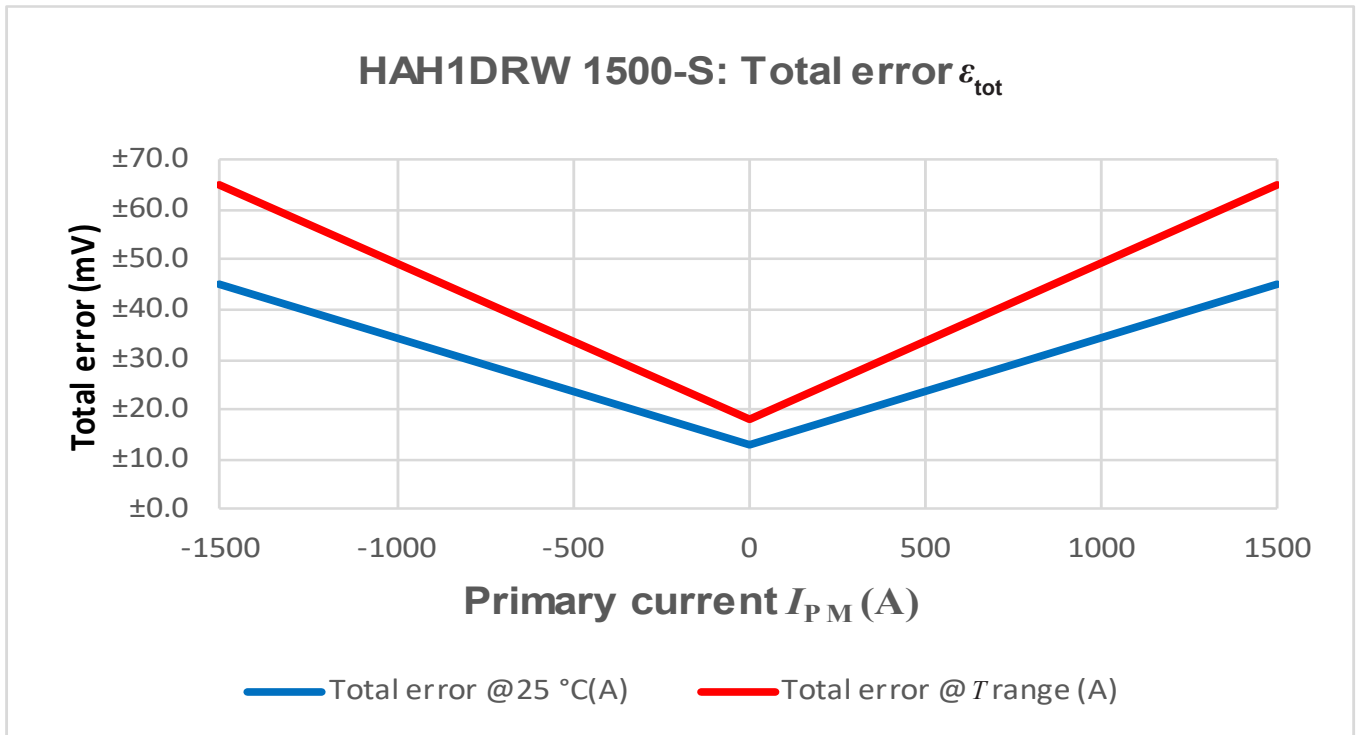
Total error ε_{tot}

I_P (A)	Total error ε_{tot} specification					
	$T_A = 25\text{ °C}, U_C = 5\text{ V}$			$-40\text{ °C} \leq T_A \leq 125\text{ °C}, U_C = 5\text{ V}$		
-1500	45 mV	33.75 A	2.25 %	65 mV	48.75 A	3.25 %
0	13 mV	9.75 A	0.65 %	18 mV	13.5 A	0.90 %
1500	45 mV	33.75 A	2.25 %	65 mV	48.75 A	3.25 %

PERFORMANCES PARAMETERS DEFINITIONS

Primary current definition:

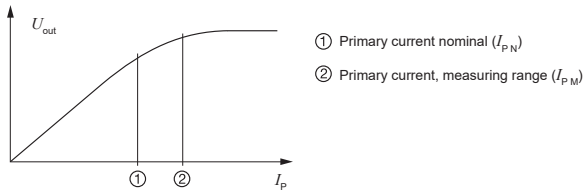

Definition of typical, minimum and maximum values:

Minimum and maximum values for specified limiting and safety conditions have to be understood as such as values shown in "typical" graphs. On the other hand, measured values are part of a statistical distribution that can be specified by an interval with upper and lower limits and a probability for measured values to lie within this interval. Unless otherwise stated (e.g. "100 % tested"), the LEM definition for such intervals designated with "min" and "max" is that the probability for values of samples to lie in this interval is 99.73 %. For a normal (Gaussian) distribution, this corresponds to an interval between -3 sigma and +3 sigma. If "typical" values are not obviously mean or average values, those values are defined to delimit intervals with a probability of 68.27 %, corresponding to an interval between -sigma and +sigma for a normal distribution. Typical, minimum and maximum values are determined during the initial characterization of a product.

Output noise voltage:

The output voltage noise is the result of the noise floor of the Hall elements and the linear amplifier.

Magnetic offset:

The magnetic offset is the consequence of an any current on the primary side. It's defined after a stated excursion of primary current.

Linearity:

The maximum positive or negative discrepancy with a reference straight line $U_{out} = f(I_p)$.
Unit: linearity (%) expressed with full scale of I_{pN} .

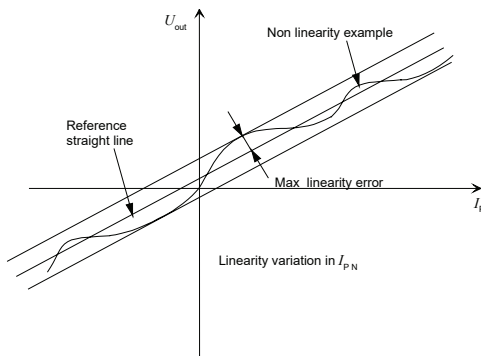

Delay time t_{D90} :

The time between the primary current signal (I_{pN}) and the output signal reach at 90 % of its final value.

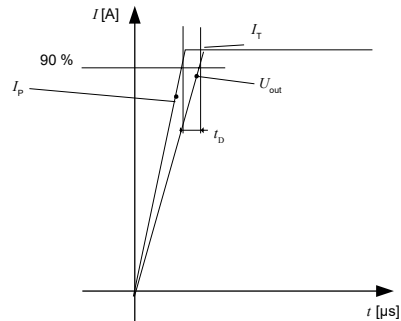

Sensitivity:

The transducer's sensitivity S is the slope of the straight line $U_{out} = f(I_p)$, it must establish the relation:

$$U_{out}(I_p) = U_c/5 (S \times I_p + U_o)$$

Offset with temperature:

The error of the offset in the operating temperature is the variation of the offset in the temperature considered with the initial offset at 25 °C.

The offset variation I_{OT} is a maximum variation the offset in the temperature range:

$$I_{OT} = I_{OE} \max - I_{OE} \min$$

The offset drift TCI_{OEAV} is the I_{OT} value divided by the temperature range.

Sensitivity with temperature:

The error of the sensitivity in the operating temperature is the relative variation of sensitivity with the temperature considered with the initial offset at 25 °C.

The sensitivity variation S_T is the maximum variation (in ppm or %) of the sensitivity in the temperature range:

$$S_T = (Sensitivity \max - Sensitivity \min) / Sensitivity \text{ at } 25 \text{ } ^\circ\text{C}.$$

The sensitivity drift TCS_{AV} is the S_T value divided by the temperature range. Deeper and detailed info available is our LEM technical sales offices (www.lem.com).

Offset voltage @ $I_p = 0$ A:

The offset voltage is the output voltage when the primary current is zero. The ideal value of U_o is $U_c/2$. So, the difference of $U_o - U_c/2$ is called the total offset voltage error. This offset error can be attributed to the electrical offset (due to the resolution of the ASIC quiescent voltage trimming), the magnetic offset, the thermal drift and the thermal hysteresis. Deeper and detailed info available is our LEM technical sales offices (www.lem.com).

Environmental test specifications:

Refer to LEM GROUP test plan laboratory CO.11.11.515.0 with "Tracking_Test Plan_Auto" sheet.

Environmental test specifications:

Name	Standard
CHARACTERIZATION @ 25 °C (initial)	
Sensitivity / Accuracy / Overall accuracy	LEM 98.20.00.574.0
Offset / Electrical Offset / Magnetic Offset	LEM 98.20.00.573.0
Linearity error	LEM 98.20.00.370.0
Current Consumption	LEM 98.20.00.579.0
CHARACTERIZATION WITH T (initial)	
Sensitivity / Accuracy / Overall accuracy	LEM 98.20.00.574.0
T variation of ... / Temperature Coefficient of S	LEM 98.20.00.574.0
Offset / Electrical Offset / Magnetic Offset	LEM 98.20.00.573.0
T variation of ... / Temperature Coefficient of Offset	LEM 98.20.00.573.0
Linearity error	LEM 98.20.00.370.0
Current Consumption	LEM 98.20.00.579.0
ELECTRICAL TESTS @ 25 °C	
Phase delay check	100 Hz to 10 kHz @ 20 A peak
Noise measurement	Sweep from DC to 1 MHz
Response time di/dt	100 A/ μ s. I pulse = 700
dv/dt	2000 V/ μ s. V = 2000 V
Dielectric Withstand Voltage test	2500 V AC / 1 min / 50Hz
Insulation Resistance test	500 V DC, time = 60 s $R_{INS} \geq 500 \text{ M}\Omega$ Minimum
ENVIRONMENTAL TESTS (CLIMATIC)	
Thermal shock	IEC 60068-2-14 Na (01/2009)
Steady state T Humidity bias life test	JESD 22-A101 (03/2009)
MECHANICAL TESTS	
Vibration Random in T	IEC 60068-2-64 (02/2008)
Shocks	IEC 60068-2-27 (02/2008)
Free Fall (Device not packaged)	IEC 60068-2-31§5.2: method 1 (05/2008)
EMC	
Immunity to ElectroStatic Discharges (Handling of devices)	ISO 10605 (07/2008)
Immunity to Conducted disturbances (BCI)	ISO 11452-4 (12/2011)
Emission Radiated (ALSE)	CISPR 25 (03/2008)
FINAL CHARACTERIZATION	
Characterization @ 25 °C	
Characterization with T	