

Current Transducer HLSR-P/SP33 series

$I_{PN} = 10 \dots 50 \text{ A}$

Ref: HLSR 10-P/SP33, HLSR 20-P/SP33, HLSR 32-P/SP33, HLSR 40-P/SP33, HLSR 50-P/SP33

For the electronic measurement of current: DC, AC, pulsed..., with galvanic separation between the primary and the secondary circuit.

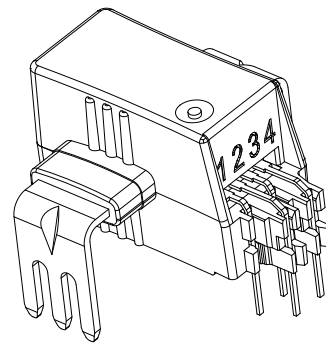

Features

- Open loop multi-range current transducer
- Voltage output
- Galvanic separation between primary and secondary
- Low power consumption
- Compact design for through-hole PCB mounting
- Factory calibrated
- High bandwidth, very low loss magnetic core.

Special feature

- Single supply +3.3 V.

Advantages

- Extremely low profile: $h = 12 \text{ mm}$
- Low foot-print
- Low offset drift
- Over-drivable U_{ref} .

Applications

- AC variable speed and servo motor drives
- Static converters for DC motor drives
- Battery supplied applications
- Uninterruptible Power Supplies (UPS)
- Switched Mode Power Supplies (SMPS)
- Power supplies for welding applications
- Combiner box
- MPPT.

Standards

- EN 50178: 1997
- IEC 61010-1: 2010
- IEC 61326-1: 2012
- UL 508: 2010.

Application Domain

- Industrial.

Absolute maximum ratings

Parameter	Symbol	Unit	Value
Maximum supply voltage (not destructive)	U_C	V	8
Maximum supply voltage (not entering non standard modes)	U_C	V	6.5
Maximum primary conductor temperature	T_B	°C	120
Electrostatic discharge voltage (HBM - Human Body Model)	$U_{ESD\ HBM}$	kV	2

Stresses above these ratings may cause permanent damage. Exposure to absolute maximum ratings for extended periods may degrade reliability.

UL 508: Ratings and assumptions of certification

File # E189713 Volume: 2 Section: 5

Standards

- CSA C22.2 NO. 14-10 INDUSTRIAL CONTROL EQUIPMENT - Edition 11 - Revision Date 2011/08/01
- UL 508 STANDARD FOR INDUSTRIAL CONTROL EQUIPMENT - Edition 17 - Revision Date 2010/04/15

Ratings

Parameter	Symbol	Unit	Value
Primary involved potential		V AC/DC	600
Max surrounding air temperature	T_A	°C	105
Primary current	I_P	A	According to series primary current
Secondary supply voltage	U_C	V DC	5
Output voltage	U_{out}	V	0 to 5

Conditions of acceptability

- 1 - These devices have been evaluated for overvoltage category III and for use in pollution degree 2 environment.
- 2 - A suitable enclosure shall be provided in the end-use application.
- 3 - The terminals have not been evaluated for field wiring.
- 4 - These devices are intended to be mounted on a printed wiring board of end use equipment. The suitability of the connections (including spacings) shall be determined in the end-use application.
- 5 - Primary terminals shall not be straightened since assembly of housing case depends upon bending of the terminals.
- 6 - Any surface of polymeric housing have not been evaluated as insulating barrier.
- 7 - Low voltage control circuit shall be supplied by an isolating source (such as a transformer, optical isolator, limiting impedance or electro-mechanical relay).

Marking

Only those products bearing the UR Mark should be considered to be Listed or Recognized and covered under UL's Follow-Up Service. Always look for the Mark on the product.

Insulation coordination

Parameter	Symbol	Unit	Value	Comment
RMS voltage for AC insulation test 50/60 Hz/1 min	U_d	kV	4.3	
Impulse withstand voltage 1.2/50 μ s	U_{Ni}	kV	8	
Clearance (pri. - sec.)	d_{Cl}	mm	> 8	Shortest distance through air
Creepage distance (pri. - sec.)	d_{Cp}	mm	> 8	Shortest path along device body
Clearance (pri. - sec.)	-	mm	8	When mounted on PCB with recommended layout
Case material	-	-	V0	According to UL 94
Comparative tracking index	CTI		600	
Application example	-	V	600	Reinforced insulation, non uniform field according to EN 50178, IEC 61010, CAT III PD2
Application example	-	V	1000	Simple insulation, non uniform field according to EN 50178, IEC 61010, CAT III PD2
Application example	-	V	600	According to UL 508, CAT III PD2

Environmental and mechanical characteristics

Parameter	Symbol	Unit	Min	Typ	Max	Comment
Ambient operating temperature	T_A	$^{\circ}$ C	-40		105	
Ambient storage temperature	T_{Ast}	$^{\circ}$ C	-40		105	
Mass	m	g			5	

Electrical data HLSR 10-P/SP33

 At $T_A = 25\text{ °C}$, $U_C = +3.3\text{ V}$, $R_L = 10\text{ k}\Omega$ unless otherwise noted (see Min, Max, typ. definition paragraph in [page 9](#)).

Parameter	Symbol	Unit	Min	Typ	Max	Comment
Primary nominal RMS current	I_{PN}	A		10		
Primary current, measuring range	I_{PM}	A	-25		25	For $U_C = 3.3\text{ V} \pm 5\%$
Number of primary turns	N_P	-		1		
Resistance of primary jumper @ $T_A = 25\text{ °C}$	R_P	m Ω		0.21		
Resistance of primary jumper @ $T_A = 105\text{ °C}$	R_P	m Ω		0.29		$T_{\text{jumper}} = 120\text{ °C}$
Supply voltage	U_C	V	3.135	3.3	3.465	
Current consumption	I_C	mA		19	25	
Reference voltage (output)	U_{ref}	V	1.63	1.65	1.67	Internal reference
Reference voltage (input)	U_{ref}	V	0.5		1.7	External reference
Output voltage range @ I_{PM}	$U_{\text{out}} - U_{\text{ref}}$	V	-1.15		1.15	Over operating temperature range
U_{ref} output resistance	R_{ref}	Ω	130	200	300	series
U_{out} output resistance	R_{out}	Ω		2	5	series
Load capacitance	C_L	nF	0		6	
Electrical offset voltage @ $I_P = 0$	U_{OE}	mV	-5		5	$U_{\text{out}} - U_{\text{ref}}$
Electrical offset current referred to primary	I_{OE}	mA	-109		109	
Temperature coefficient of U_{ref}	TCU_{ref}	ppm/K	-150		150	-40 °C ... 105 °C
Temperature coefficient of U_{OE}	TCU_{OE}	mV/K	-0.075		0.075	
Temperature coefficient of I_{OE}	TCI_{OE}	mA/K	-1.63		1.63	
Nominal sensitivity	S_N	mV/A		46		460 mV @ I_{PN}
Sensitivity error	ε_S	%	-0.5		0.5	Factory adjustment
Temperature coefficient of S	TCS	ppm/K	-200		200	
Linearity error 0 ... I_{PN}	ε_L	% of I_{PN}	-0.5		0.5	
Linearity error 0 ... I_{PM}	ε_L	% of I_{PM}	-0.8		0.8	
Magnetic offset current (@ $10 \times I_{PN}$) referred to primary	I_{OM}	A	-0.25		0.25	
Delay time @ 10 % of the final output value I_{PN} step	t_{D10}	μs			2	@ 50 A/ μs
Delay time @ 90 % of the final output value I_{PN} step	t_{D90}	μs			2.5	@ 50 A/ μs
Frequency bandwidth (-3 dB)	BW	kHz		450		
RMS noise voltage spectral density 100 Hz ... 100 kHz	u_{no}	$\mu\text{V}/\sqrt{\text{Hz}}$			16	
RMS noise voltage DC ... 10 kHz DC ... 100 kHz DC ... 1 MHz	U_{no}	mVpp		9 22 40		
Sum of sensitivity and linearity @ I_{PN}	ε_{SL}	% of I_{PN}	-1		1	
Sum of sensitivity and linearity @ I_{PN} @ $T_A = +85\text{ °C}$	ε_{SL85}	% of I_{PN}	-3.2		3.2	See formula note ¹⁾
Sum of sensitivity and linearity @ I_{PN} @ $T_A = +105\text{ °C}$	ε_{SL105}	% of I_{PN}	-3.9		3.9	See formula note ¹⁾

Note: ¹⁾ $\varepsilon_{SL}(T_A) = \varepsilon_{SL25} + \left(TCS + \frac{TCI_{OE}}{I_{PN}} \right) \times |T_A - 25|$

Electrical data HLSR 20-P/SP33

 At $T_A = 25\text{ °C}$, $U_C = +3.3\text{ V}$, $R_L = 10\text{ k}\Omega$ unless otherwise noted (see Min, Max, typ. definition paragraph in [page 9](#)).

Parameter	Symbol	Unit	Min	Typ	Max	Comment
Primary nominal RMS current	I_{PN}	A		20		
Primary current, measuring range	I_{PM}	A	-50		50	For $U_C = 3.3\text{ V} \pm 5\%$
Number of primary turns	N_P	-		1		
Resistance of primary jumper @ $T_A = 25\text{ °C}$	R_P	m Ω		0.21		
Resistance of primary jumper @ $T_A = 105\text{ °C}$	R_P	m Ω		0.29		T jumper = 120 °C
Supply voltage	U_C	V	3.135	3.3	3.465	
Current consumption	I_C	mA		19	25	
Reference voltage (output)	U_{ref}	V	1.63	1.65	1.67	Internal reference
Reference voltage (input)	U_{ref}	V	0.5		1.7	External reference
Output voltage range @ I_{PM}	$U_{out} - U_{ref}$	V	-1.15		1.15	Over operating temperature range
U_{ref} output resistance	R_{ref}	Ω	130	200	300	series
U_{out} output resistance	R_{out}	Ω		2	5	series
Load capacitance	C_L	nF	0		6	
Electrical offset voltage @ $I_P = 0$	U_{OE}	mV	-5		5	$U_{out} - U_{ref}$
Electrical offset current referred to primary	I_{OE}	mA	-217		217	
Temperature coefficient of U_{ref}	TCU_{ref}	ppm/K	-150		150	-40 °C ... 105 °C
Temperature coefficient of U_{OE}	TCU_{OE}	mV/K	-0.075		0.075	
Temperature coefficient of I_{OE}	TCI_{OE}	mA/K	-3.26		3.26	
Nominal sensitivity	S_N	mV/A		23		460 mV @ I_{PN}
Sensitivity error	ϵ_S	%	-0.5		0.5	Factory adjustment
Temperature coefficient of S	TCS	ppm/K	-200		200	
Linearity error 0 ... I_{PN}	ϵ_L	% of I_{PN}	-0.5		0.5	
Linearity error 0 ... I_{PM}	ϵ_L	% of I_{PM}	-0.8		0.8	
Magnetic offset current (@ $10 \times I_{PN}$) referred to primary	I_{OM}	A	-0.25		0.25	
Delay time @ 10 % of the final output value I_{PN} step	t_{D10}	μs			2	@ 50 A/ μs
Delay time @ 90 % of the final output value I_{PN} step	t_{D90}	μs			2.5	@ 50 A/ μs
Frequency bandwidth (-3 dB)	BW	kHz		450		
RMS noise voltage spectral density 100 Hz ... 100 kHz	u_{no}	$\mu\text{V}/\sqrt{\text{Hz}}$			8	
RMS noise voltage DC ... 10 kHz DC ... 100 kHz DC ... 1 MHz	U_{no}	mVpp		6 13 23		
Sum of sensitivity and linearity @ I_{PN}	ϵ_{SL}	% of I_{PN}	-1		1	
Sum of sensitivity and linearity @ I_{PN} @ $T_A = +85\text{ °C}$	ϵ_{SL85}	% of I_{PN}	-3.2		3.2	See formula note ¹⁾
Sum of sensitivity and linearity @ I_{PN} @ $T_A = +105\text{ °C}$	ϵ_{SL105}	% of I_{PN}	-3.9		3.9	See formula note ¹⁾

Note: ¹⁾ $\epsilon_{SL}(T_A) = \epsilon_{SL25} + \left(TCS + \frac{TCI_{OE}}{I_{PN}} \right) \times |T_A - 25|$

Electrical data HLSR 32-P/SP33

 At $T_A = 25\text{ °C}$, $U_C = +3.3\text{ V}$, $R_L = 10\text{ k}\Omega$ unless otherwise noted (see Min, Max, typ. definition paragraph in [page 9](#)).

Parameter	Symbol	Unit	Min	Typ	Max	Comment
Primary nominal RMS current	I_{PN}	A		32		
Primary current, measuring range	I_{PM}	A	-80		80	For $U_C = 3.3\text{ V} \pm 5\%$
Number of primary turns	N_P	-		1		
Resistance of primary jumper @ $T_A = 25\text{ °C}$	R_P	m Ω		0.21		
Resistance of primary jumper @ $T_A = 105\text{ °C}$	R_P	m Ω		0.29		$T_{\text{jumper}} = 120\text{ °C}$
Supply voltage	U_C	V	3.135	3.3	3.465	
Current consumption	I_C	mA		19	25	
Reference voltage (output)	U_{ref}	V	1.63	1.65	1.67	Internal reference
Reference voltage (input)	U_{ref}	V	0.5		1.7	External reference
Output voltage range @ I_{PM}	$U_{out} - U_{ref}$	V	-1.15		1.15	Over operating temperature range
U_{ref} output resistance	R_{ref}	Ω	130	200	300	series
U_{out} output resistance	R_{out}	Ω		2	5	series
Load capacitance	C_L	nF	0		6	
Electrical offset voltage @ $I_p = 0$	U_{OE}	mV	-5		5	$U_{out} - U_{ref}$
Electrical offset current referred to primary	I_{OE}	mA	-348		348	
Temperature coefficient of U_{ref}	TCU_{ref}	ppm/K	-150		150	-40 °C ... 105 °C
Temperature coefficient of U_{OE}	TCU_{OE}	mV/K	-0.075		0.075	
Temperature coefficient of I_{OE}	TCI_{OE}	mA/K	-5.22		5.22	
Nominal sensitivity	S_N	mV/A		14.375		460 mV @ I_{PN}
Sensitivity error	ε_S	%	-0.5		0.5	Factory adjustment
Temperature coefficient of S	TCS	ppm/K	-200		200	
Linearity error 0 ... I_{PN}	ε_L	% of I_{PN}	-0.5		0.5	
Linearity error 0 ... I_{PM}	ε_L	% of I_{PM}	-0.8		0.8	
Magnetic offset current (@ $10 \times I_{PN}$) referred to primary	I_{OM}	A	-0.25		0.25	
Delay time @ 10 % of the final output value I_{PN} step	t_{D10}	μs			2	@ 50 A/ μs
Delay time @ 90 % of the final output value I_{PN} step	t_{D90}	μs			2.5	@ 50 A/ μs
Frequency bandwidth (-3 dB)	BW	kHz		450		
RMS noise voltage spectral density 100 Hz ... 100 kHz	u_{no}	$\mu\text{V}/\sqrt{\text{Hz}}$			5	
RMS noise voltage DC ... 10 kHz DC ... 100 kHz DC ... 1 MHz	U_{no}	mVpp		4 10 16		
Sum of sensitivity and linearity @ I_{PN}	ε_{SL}	% of I_{PN}	-1		1	
Sum of sensitivity and linearity @ I_{PN} @ $T_A = +85\text{ °C}$	ε_{SL85}	% of I_{PN}	-3.2		3.2	See formula note ¹⁾
Sum of sensitivity and linearity @ I_{PN} @ $T_A = +105\text{ °C}$	ε_{SL105}	% of I_{PN}	-3.9		3.9	See formula note ¹⁾

Note: ¹⁾ $\varepsilon_{SL}(T_A) = \varepsilon_{SL25} + \left(TCS + \frac{TCI_{OE}}{I_{PN}} \right) \times |T_A - 25|$

Electrical data HLSR 40-P/SP33

 At $T_A = 25\text{ °C}$, $U_C = +3.3\text{ V}$, $R_L = 10\text{ k}\Omega$ unless otherwise noted (see Min, Max, typ. definition paragraph in [page 9](#)).

Parameter	Symbol	Unit	Min	Typ	Max	Comment
Primary nominal RMS current	I_{PN}	A		40		
Primary current, measuring range	I_{PM}	A	-100		100	For $U_C = 3.3\text{ V} \pm 5\%$
Number of primary turns	N_P	-		1		
Resistance of primary jumper @ $T_A = 25\text{ °C}$	R_P	m Ω		0.21		
Resistance of primary jumper @ $T_A = 105\text{ °C}$	R_P	m Ω		0.29		$T_{\text{jumper}} = 120\text{ °C}$
Supply voltage	U_C	V	3.135	3.3	3.465	
Current consumption	I_C	mA		19	25	
Reference voltage (output)	U_{ref}	V	1.63	1.65	1.67	Internal reference
Reference voltage (input)	U_{ref}	V	0.5		1.7	External reference
Output voltage range @ I_{PM}	$U_{out} - U_{ref}$	V	-1.15		1.15	Over operating temperature range
U_{ref} output resistance	R_{ref}	Ω	130	200	300	series
U_{out} output resistance	R_{out}	Ω		2	5	series
Load capacitance	C_L	nF	0		6	
Electrical offset voltage @ $I_p = 0$	U_{OE}	mV	-5		5	$U_{out} - U_{ref}$
Electrical offset current referred to primary	I_{OE}	mA	-435		435	
Temperature coefficient of U_{ref}	TCU_{ref}	ppm/K	-150		150	-40 °C ... 105 °C
Temperature coefficient of U_{OE}	TCU_{OE}	mV/K	-0.075		0.075	
Temperature coefficient of I_{OE}	TCI_{OE}	mA/K	-6.52		6.52	
Nominal sensitivity	S_N	mV/A		11.5		460 mV @ I_{PN}
Sensitivity error	ε_S	%	-0.5		0.5	Factory adjustment
Temperature coefficient of S	TCS	ppm/K	-200		200	
Linearity error 0 ... I_{PN}	ε_L	% of I_{PN}	-0.5		0.5	
Linearity error 0 ... I_{PM}	ε_L	% of I_{PM}	-0.8		0.8	
Magnetic offset current (@ $10 \times I_{PN}$) referred to primary	I_{OM}	A	-0.25		0.25	
Delay time @ 10 % of the final output value I_{PN} step	t_{D10}	μs			2	@ 50 A/ μs
Delay time @ 90 % of the final output value I_{PN} step	t_{D90}	μs			2.5	@ 50 A/ μs
Frequency bandwidth (-3 dB)	BW	kHz		450		
RMS noise voltage spectral density 100 Hz ... 100 kHz	u_{no}	$\mu\text{V}/\sqrt{\text{Hz}}$			4.5	
RMS noise voltage DC ... 10 kHz DC ... 100 kHz DC ... 1 MHz	U_{no}	mVpp		4 9 14		
Sum of sensitivity and linearity @ I_{PN}	ε_{SL}	% of I_{PN}	-1		1	
Sum of sensitivity and linearity @ I_{PN} @ $T_A = +85\text{ °C}$	ε_{SL85}	% of I_{PN}	-3.2		3.2	See formula note ¹⁾
Sum of sensitivity and linearity @ I_{PN} @ $T_A = +105\text{ °C}$	ε_{SL105}	% of I_{PN}	-3.9		3.9	See formula note ¹⁾

Note: ¹⁾ $\varepsilon_{SL}(T_A) = \varepsilon_{SL25} + \left(TCS + \frac{TCI_{OE}}{I_{PN}} \right) \times |T_A - 25|$

Electrical data HLSR 50-P/SP33

 At $T_A = 25\text{ °C}$, $U_C = +3.3\text{ V}$, $R_L = 10\text{ k}\Omega$ unless otherwise noted (see Min, Max, typ. definition paragraph in [page 9](#)).

Parameter	Symbol	Unit	Min	Typ	Max	Comment
Primary nominal RMS current	I_{PN}	A		50		
Primary current, measuring range	I_{PM}	A	-125		125	For $U_C = 3.3\text{ V} \pm 5\%$
Number of primary turns	N_P	-		1		
Resistance of primary jumper @ $T_A = 25\text{ °C}$	R_P	m Ω		0.21		
Resistance of primary jumper @ $T_A = 105\text{ °C}$	R_P	m Ω		0.29		$T_{\text{jumper}} = 120\text{ °C}$
Supply voltage	U_C	V	3.135	3.3	3.465	
Current consumption	I_C	mA		19	25	
Reference voltage (output)	U_{ref}	V	1.63	1.65	1.67	Internal reference
Reference voltage (input)	U_{ref}	V	0.5		1.7	External reference
Output voltage range @ I_{PM}	$U_{out} - U_{ref}$	V	-1.15		1.15	Over operating temperature range
U_{ref} output resistance	R_{ref}	Ω	130	200	300	series
U_{out} output resistance	R_{out}	Ω		2	5	series
Load capacitance	C_L	nF	0		6	
Electrical offset voltage @ $I_p = 0$	U_{OE}	mV	-5		5	$U_{out} - U_{ref}$
Electrical offset current referred to primary	I_{OE}	mA	-543		543	
Temperature coefficient of U_{ref}	TCU_{ref}	ppm/K	-150		150	-40 °C ... 105 °C
Temperature coefficient of U_{OE}	TCU_{OE}	mV/K	-0.075		0.075	
Temperature coefficient of I_{OE}	TCI_{OE}	mA/K	-8.15		8.15	
Nominal sensitivity	S_N	mV/A		9.2		460 mV @ I_{PN}
Sensitivity error	ε_G	%	-0.5		0.5	Factory adjustment
Temperature coefficient of S	TCS	ppm/K	-200		200	
Linearity error 0 ... I_{PN}	ε_L	% of I_{PN}	-0.5		0.5	
Linearity error 0 ... I_{PM}	ε_L	% of I_{PM}	-0.8		0.8	
Magnetic offset current (@ $10 \times I_{PN}$) referred to primary	I_{OM}	A	-0.25		0.25	
Delay time @ 10 % of the final output value I_{PN} step	t_{D10}	μs			2	@ 50 A/ μs
Delay time @ 90 % of the final output value I_{PN} step	t_{D90}	μs			2.5	@ 50 A/ μs
Frequency bandwidth (-3 dB)	BW	kHz		450		
RMS noise voltage spectral density 100 Hz ... 100 kHz	u_{no}	$\mu\text{V}/\sqrt{\text{Hz}}$			4	
RMS noise voltage DC ... 10 kHz DC ... 100 kHz DC ... 1 MHz	U_{no}	mVpp		3.3 7.3 12		
Sum of sensitivity and linearity @ I_{PN}	ε_{SL}	% of I_{PN}	-1		1	
Sum of sensitivity and linearity @ I_{PN} @ $T_A = +85\text{ °C}$	ε_{SL85}	% of I_{PN}	-3.2		3.2	See formula note ¹⁾
Sum of sensitivity and linearity @ I_{PN} @ $T_A = +105\text{ °C}$	ε_{SL105}	% of I_{PN}	-3.9		3.9	See formula note ¹⁾

Note: ¹⁾ $\varepsilon_{SL}(T_A) = \varepsilon_{SL25} + \left(TCS + \frac{TCI_{OE}}{I_{PN}} \right) \times |T_A - 25|$

Maximum continuous DC current

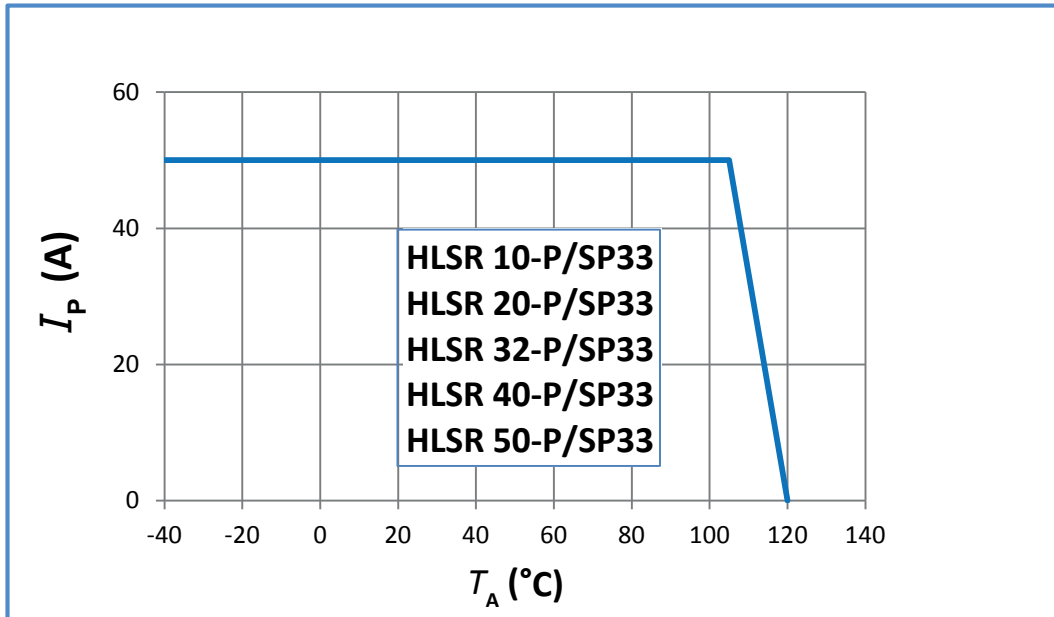

Important notice: whatever the usage and/or application, the transducer jumper temperature shall not go above the maximum ratings of 120 °C as stated in page 2 of this datasheet.

Definition of typical, minimum and maximum values

Minimum and maximum values for specified limiting and safety conditions have to be understood as such as well as values shown in “typical” graphs.

On the other hand, measured values are part of a statistical distribution that can be specified by an interval with upper and lower limits and a probability for measured values to lie within this interval.

Unless otherwise stated (e.g. “100 % tested”), the LEM definition for such intervals designated with “min” and “max” is that the probability for values of samples to lie in this interval is 99.73 %.

For a normal (Gaussian) distribution, this corresponds to an interval between -3 sigma and +3 sigma. If “typical” values are not obviously mean or average values, those values are defined to delimit intervals with a probability of 68.27 %, corresponding to an interval between -sigma and +sigma for a normal distribution.

Typical, minimum and maximum values are determined during the initial characterization of the product.

Measuring range versus external reference voltage

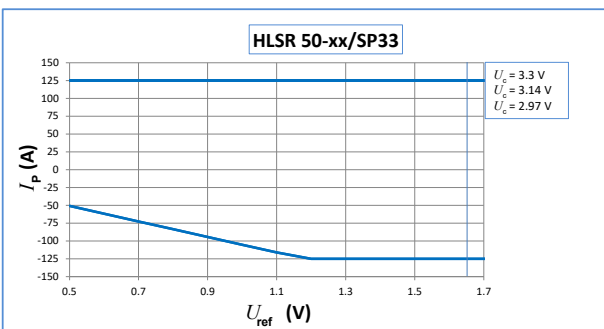
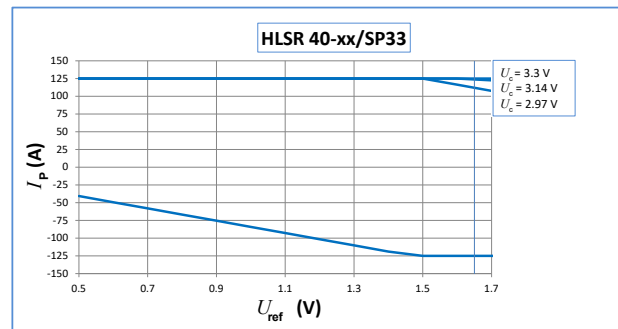
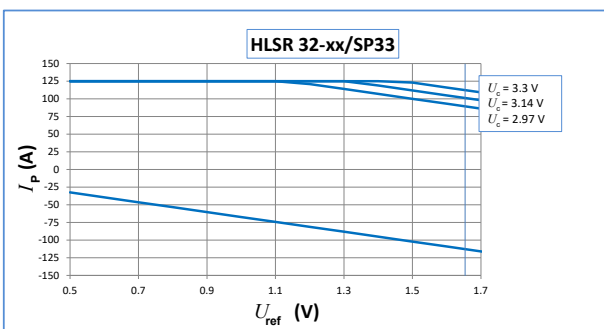
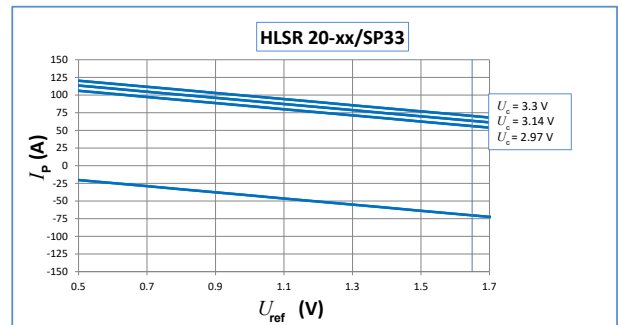
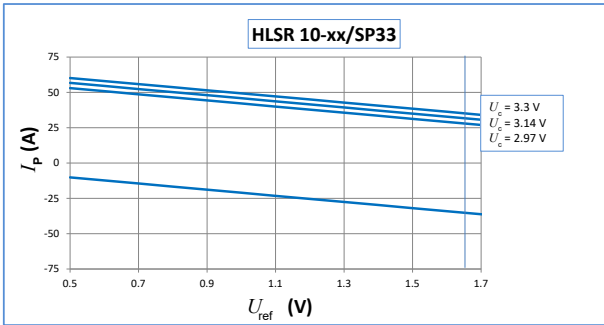

Dimensions (in mm. General linear tolerance ± 0.2 mm)

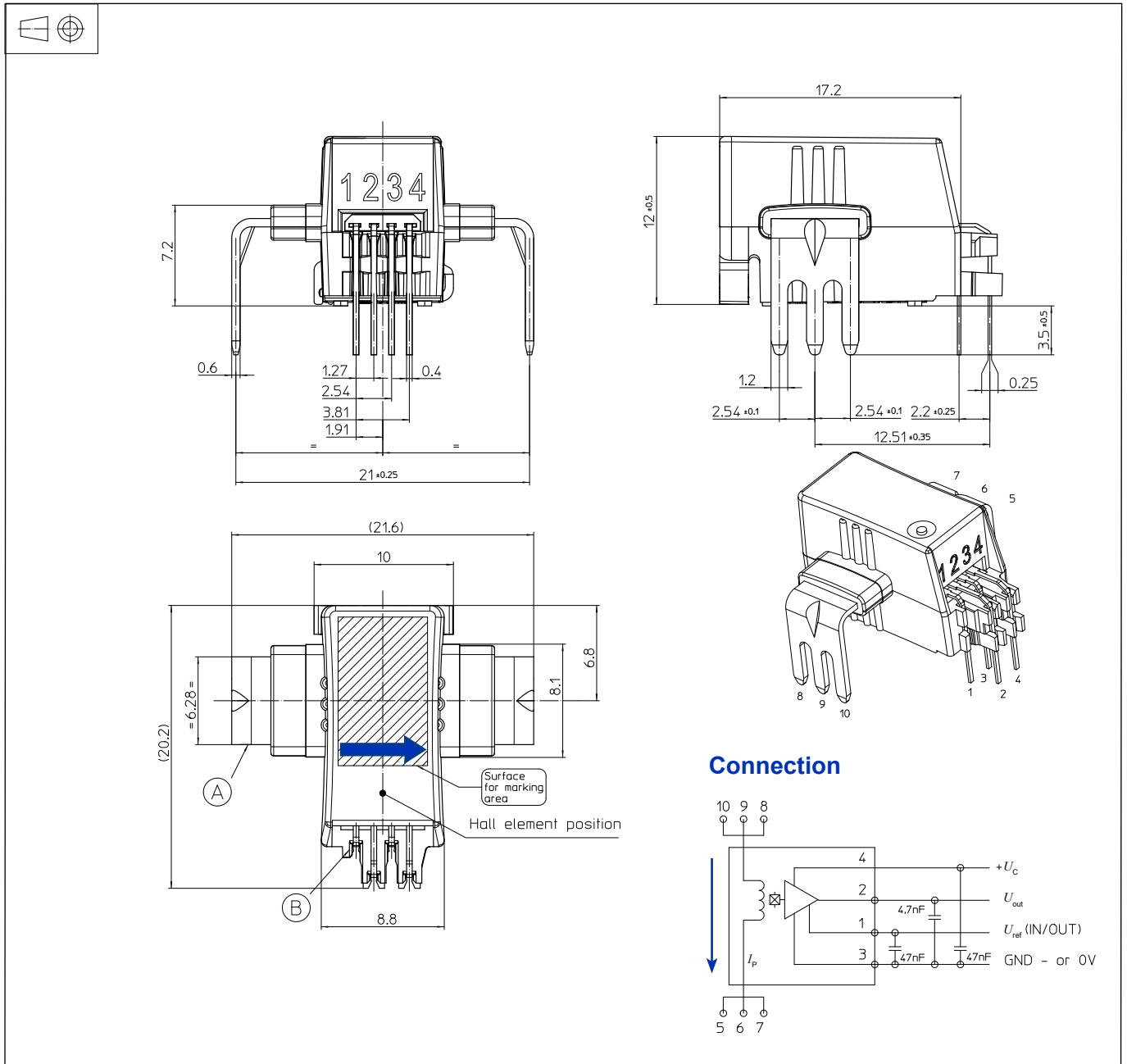

Remarks

- U_{out} is positive with respect to U_{ref} when positive I_p flows in direction of the arrow shown on the drawing above
- Installation of the transducer must be done unless otherwise specified on the datasheet, according to LEM Transducer Generic Mounting Rules. Please refer to LEM document N°ANE120504 available on our Web site: <https://www.lem.com/en/file/3137/download/>.

IMPORTANT NOTICE

The information in this document is considered accurate and reliable. However, LEM International SA and any company directly or indirectly controlled by LEM Holding SA ("LEM") do not provide any guarantee or warranty, expressed or implied, regarding the accuracy or completeness of this information and are not liable for any consequences resulting from its use. LEM shall not be responsible for any indirect, incidental, punitive, special, or consequential damages (including, but not limited to, lost profits, lost savings, business interruption, costs related to the removal or replacement of products, or rework charges) regardless of whether such damages arise from tort (including negligence), warranty, breach of contract, or any other legal theory.

LEM reserves the right to update the information in this document, including specifications and product descriptions, at any time without prior notice. Information in this document replaces any previous versions of this document. No license to any intellectual property is granted by LEM through this document, either explicitly or implicitly. Any Information and product described herein is subject to export control regulations.

LEM products may possess either unidentified or documented vulnerabilities. It is the sole responsibility of the purchaser to design and operate their applications and products in a manner that mitigates the impact of these vulnerabilities. LEM disclaims any liability for such vulnerabilities. Customers must select products with security features that best comply with applicable rules, regulations, and standards for their intended use. The purchaser is responsible for making final design decisions regarding its products and for ensuring compliance with all legal, regulatory, and security-related requirements, irrespective of any information or support provided by LEM.

LEM products are not intended, authorized, or warranted for use in life support, life-critical, or safety-critical systems or equipment, nor in applications where failure or malfunction of an LEM product could result in personal injury, death, or significant property or environmental damage. LEM and its suppliers do not assume liability for the inclusion and/or use of LEM products in such equipment or applications; thus, this inclusion and/or use is at the purchaser's own and sole risk. Unless explicitly stated that a specific LEM product is automotive qualified, it should not be used in automotive applications. LEM does not accept liability for the inclusion and/or use of non-automotive qualified products in automotive equipment or applications.

Applications that are described herein are for illustrative purposes only. LEM makes no representation or warranty that LEM products will be suitable for a particular purpose, a specified use or application. The purchaser is solely responsible for the design and operation of its applications and devices using LEM products, and LEM accepts no liability for any assistance with any application or purchaser product design. It is purchaser's sole responsibility to determine whether the LEM product is suitable and fit for the purchaser's applications and products planned, as well as for the planned application and use of purchaser's third-party customer(s).

Stressing and using LEM products at or above limiting values will cause permanent damage to the LEM product and potentially to any device embedding or operating with LEM product. Limiting values are stress ratings only and operation of the LEM product at or above conditions and limits given in this document is not warranted. Continuous or repeated exposure to limiting values will permanently and irreversibly affect the quality and reliability of the LEM product.

LEM products are sold subject to the general terms and conditions of commercial sale, as published at www.lem.com unless otherwise agreed in a specific written agreement. LEM hereby expressly rejects the purchaser's general terms and conditions for purchasing LEM products by purchaser. Any terms and conditions contained in any document issued by the purchaser either before or after issuance of any document by LEM containing or referring to the general terms and conditions of sale are explicitly rejected and disregarded by LEM, and the document issued by the purchaser is wholly inapplicable to any sale or licensing made by LEM and is not binding in any way on LEM.

© 2025 LEM INTERNATIONAL SA – All rights reserved