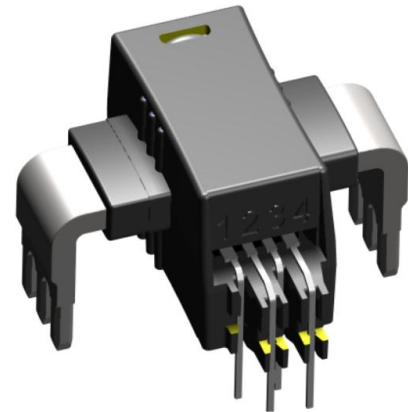

Ref: HLSR 120-P/SP59

For the electronic measurement of current: *DC, AC, pulsed...*, with galvanic separation between the primary and the secondary circuit.

**Features**

- Open loop current transducer
- Voltage output
- Single power supply +5V± 5%
- Galvanic separation between primary and secondary
- Low power consumption
- Compact design for PCB mounting
- Factory calibrated.

Special features

- 1.6mm busbar.

Advantages

- Small footprint
- Low offset drift
- High bandwidth
- Low response time.

Applications

- AC variable speed and servo motor drivers
- Static converters for DC motor drivers
- Battery supplied applications
- Uninterruptible-Power Supplies (UPS)
- Switched Mode-Power Supplies (SMPS)
- Combiner box
- MPPT.

Standards

- EN IEC 62477-1:2023
- EN IEC 62040-1:2019+A11+A1
- EN 61010-1:2010+A1
- EN IEC 61800-5-1:2023
- EN 62109-1:2010.

Application Domain

- Industrial.

Safety



Caution

If the device is used in a way that is not specified by the manufacturer, the protection provided by the device may be compromised. Always inspect the electronics unit and connecting cable before using this product and do not use it if damaged. Mounting assembly shall guarantee the maximum primary conductor temperature, fulfill clearance and creepage distance, minimize electric and magnetic coupling, and unless otherwise specified can be mounted in any orientation.



Caution, risk of electrical shock

This transducer must be used in limited-energy secondary circuits SELV according to IEC 61010-1, in electric/electronic equipment with respect to applicable standards and safety requirements in accordance with the manufacturer's operating specifications.

Use caution during installation and use of this product; certain parts of the module can carry hazardous voltages and high currents (e.g. power supply, primary conductor).

Ignoring this warning can lead to injury and or/or cause serious damage.

De-energize all circuits and hazardous live parts before installing the product.

All installations, maintenance, servicing operations and use must be carried out by trained and qualified personnel practicing applicable safety precautions.

This transducer is a built-in device, whose hazardous live parts must be inaccessible after installation.

This transducer must be mounted in a suitable end-enclosure.

Besides make sure to have a distance of minimum 30 mm between the primary terminals of the transducer and other neighboring components.

Main supply must be able to be disconnected.

Always inspect the flexible probe for damage before using this product.

Never connect or disconnect the external power supply while the primary circuit is connected to live parts.

Never connect the output to any equipment with a common mode voltage to earth greater than 30 V.

Always wear protective clothing and gloves if hazardous live parts are present in the installation where the measurement is carried out.

This transducer is a built-in device, not intended to be cleaned with any product. Nevertheless if the user must implement cleaning or washing process, validation of the cleaning program has to be done by himself.

When defining soldering process, please use no cleaning process only.



ESD susceptibility

The product is susceptible to be damaged from an ESD event and the personnel should be grounded when handling it.

Do not dispose of this product as unsorted municipal waste. Contact a qualified recycler for disposal.

Although LEM applies utmost care to facilitate compliance of end products with applicable regulations during LEM product design, use of this part may need additional measures on the application side for compliance with regulations regarding EMC and protection against electric shock. Therefore LEM cannot be held liable for any potential hazards, damages, injuries or loss of life resulting from the use of this product.



Underwriters Laboratory Inc. recognized component

Absolute maximum ratings

Parameter	Symbol	Unit	Value
Maximum supply voltage (not destruction < 1 min)	$U_{C\ max}$	V	8
Maximum supply voltage (not entering non standard modes)	$U_{C\ max}$	V	6.5
Maximum primary conductor temperature	$T_{B\ max}$	°C	120
Electrostatic discharge voltage (HBM - Human Body Model)	$U_{ESD\ HBM}$	kV	2
Electrostatic discharge voltage (CDM – Charged Device Model)	$U_{ESD\ CDM}$	kV	0.5

Stresses above these ratings may cause permanent damage.
Exposure to absolute maximum ratings for extended periods may degrade reliability.

UL 508: Ratings and assumptions of certification

File # E189713 (refer to existing HLSR-P family, the final data is subject to the UL file)

Standards

- CSA C22.2 NO. 14-10 INDUSTRIAL CONTROL EQUIPMENT - Edition 11 - Revision Date 2011/08/01
- UL 508 STANDARD FOR INDUSTRIAL CONTROL EQUIPMENT - Edition 17 - Revision Date 2010/04/15

Ratings

Parameter	Symbol	Unit	Value
Primary involved potential		V AC/DC	600
Ambient operating temperature	T_A	°C	105
Primary current	I_p	A	120
Secondary supply voltage	U_C	V DC	5
Output voltage	U_{out}	V	0 to 5

Conditions of acceptability

- 1 - These devices have been evaluated for overvoltage category III and for use in pollution degree 2 environment.
- 2 - A suitable enclosure shall be provided in the end-use application.
- 3 - The terminals have not been evaluated for field wiring.
- 4 - These devices are intended to be mounted on a printed wiring board of end use equipment. The suitability of the connections (including spacings) shall be determined in the end-use application.
- 5 - Primary terminals shall not be straightened since assembly of housing case depends upon bending of the terminals.
- 6 - Any surface of polymeric housing have not been evaluated as insulating barrier.
- 7 - Low voltage control circuit shall be supplied by an isolating source (such as a transformer, optical isolator, limiting impedance or electro-mechanical relay).

Marking

Only those products bearing the UR Mark should be considered to be Listed or Recognized and covered under UL's Follow-Up Service. Always look for the Mark on the product.

Environmental and mechanical characteristics

Parameter	Symbol	Unit	Min	Typ	Max	Comment
Ambient operating temperature	T_A	°C	-40		105	
Ambient storage temperature	$T_{A\text{st}}$	°C	-40		105	
Mass	m	g		7.5		

Insulation coordination

Parameter	Symbol	Unit	≤ Value	Comment
RMS voltage for AC insulation test, 50 Hz, 1 min	U_d	kV	4.3	
Impulse withstand voltage 1.2/50 μs	U_{Ni}	kV	8	
Clearance (pri. - sec.)	d_{Cl}	mm	>8	Shortest distance through air
Creepage distance (pri. - sec.)	d_{Cp}	mm	>8	Shortest path along device body
Case material	-	-	V0	According to UL 94
Comparative tracking index	CTI		600	
Application example		V	300	Reinforced insulation, CAT III, PD2 non uniform field according to IEC 61010-1
Application example		V	1000	Basic insulation, CAT III, PD2 non uniform field according to IEC 61010-1

Electrical data

At $T_A = 25\text{ °C}$, $U_C = +5\text{ V}$, $R_L = 10\text{ k}\Omega$ unless otherwise noted (see Min, Max, typ, definition paragraph in page 6).

Parameter	Symbol	Unit	Min	Typ	Max	Comment
Primary nominal AC RMS current (continuous)	I_{PN}	A		120		$f \leq 100\text{ Hz}$
Primary current, measuring range	I_{PM}	A		300		With $\pm U_C > 4.7\text{ V}$
Supply voltage	U_C	V	4.75	5	5.25	
Reference voltage range@ I_{PM}	$U_{out} - U_{ref}$	V	-2		2	
Output voltage @ $I_P = 0\text{ A}$	U_{OE}	mV	-5		5	
Reference voltage	U_{ref}	V	2.48	2.5	2.52	
Temperature coefficient of U_{ref}	TCU_{ref}	ppm/K	-100		100	-40 °C ... 105 °C
Temperature coefficient of U_{OE}	TCU_{OE}	mV/K	-0.05		0.05	-40 °C ... 105 °C
Sensitivity	S_{th}	mV/A		6.667		800mV@ I_{PN}
Sensitivity error@ I_{PN} @ $T_A = 25\text{ °C}$	ϵ_s	%	-0.85		0.85	
Temperature coefficient of S_{th}	TCS	ppm/K	-250		250	-40 °C ... 105 °C
Linearity error	ϵ_L	%		0.5		
Capacitive loading	C_L	pF		10	10000	For Pin Uout and Uref
Magnetic offset current(@ $10 \times I_{PN}$)	I_{OM}	A	-0.5		0.5	
Total error@ I_{PN} @ $T_A = 25\text{ °C}$	ϵ_{tot25}	% of I_{PN}	-1.5		1.5	
Total error@ I_{PN} @ $T_A = -30\text{ °C} \dots 85\text{ °C}$	ϵ_{tot85}	% of I_{PN}	-2.5		2.5	
Total error@ I_{PN} @ $T_A = -40\text{ °C} \dots 105\text{ °C}$	ϵ_{tot105}	% of I_{PN}	-3		3	
Sum of sensitivity and linearity @ I_{PN} @ $T_A = 25\text{ °C}$	ϵ_{SL25}	% of I_{PN}	-1		1	
Sum of sensitivity and linearity @ I_{PN} @ $T_A = -30\text{ °C} \dots 85\text{ °C}$	ϵ_{SL85}	% of I_{PN}	-2.1		2.1	
Sum of sensitivity and linearity @ I_{PN} @ $T_A = -40\text{ °C} \dots 105\text{ °C}$	ϵ_{SL105}	% of I_{PN}	-2.6		2.6	
Noise voltage spectral density 100 Hz ... 100 kHz	U_{no}	$\mu\text{V}/\sqrt{\text{Hz}}$		0.159		
Noise voltage DC ... 10 kHz DC ... 100 kHz DC ... 1 MHz	U_{no}	mVpp		1.44 4.6 15		
Delay time to 10 % of the final output value I_{PN} step	t_{D10}	μs		0.5	1	@ 30A/us
Delay time to 90 % of the final output value I_{PN} step	t_{D90}	μs		0.5	1	@ 30A/us
Frequency bandwidth (-3 dB)	BW	kHz	200			Loading capacitance of 10 pF for Uout

Definition of typical, minimum and maximum values

Minimum and maximum values for specified limiting and safety conditions have to be understood as such as well as values shown in “typical” graphs.

On the other hand, measured values are part of a statistical distribution that can be specified by an interval with upper and lower limits and a probability for measured values to lie within this interval.

Unless otherwise stated (e.g. “100 % tested”), the LEM definition for such intervals designated with “min” and “max” is that the probability for values of samples to lie in this interval is 99.73 %.

For a normal (Gaussian) distribution, this corresponds to an interval between -3 sigma and $+3$ sigma. If “typical” values are not obviously mean or average values, those values are defined to delimit intervals with a probability of 68.27 %, corresponding to an interval between $-\text{sigma}$ and $+\text{sigma}$ for a normal distribution.

Typical, maximal and minimal values are determined during the initial characterization of the product.

Terms and definitions

Ampere-turns and amperes

The transducer is sensitive to the primary current linkage Θ_p (also called ampere-turns).

$$\Theta_p = N_p \cdot I_p$$

Where N_p is the number of primary turn (depending on the connection of the primary jumpers).

Caution: As most applications will use the transducer with only one single primary turn ($N_p = 1$), much of this datasheet is written in terms of primary current instead of current linkages. However, the ampere-turns (A) unit is used to emphasis that current linkages are intended and applicable.

Simplified transducer model

The static model of the transducer with current output at temperature T_A is:

$$I_S = S \cdot \Theta_p \cdot (1 + \varepsilon)$$

In which (referred to primary):

$$\varepsilon \cdot \Theta_p = I_{OE} + I_{OT} + \varepsilon_s \cdot \Theta_p + \varepsilon_{ST} \cdot \Theta_p + \varepsilon_L(\Theta_{Pmax}) \cdot \Theta_{Pmax} + I_{OM}$$

$$\Theta_p = N_p \cdot I_p$$

: primary current linkage (A)

Θ_{Pmax} : maximum primary current linkage applied to the transducer

I_S : secondary current (A)

U_{out} : output voltage (V)

S : sensitivity of the transducer

T_A : ambient operating temperature (°C)

I_{OE} : electrical offset current (A)

I_{OM} : magnetic offset current (A)

I_{OT} : temperature variation of I_{OE} (A)

ε_s : sensitivity error at 25 °C

ε_{ST} : thermal drift of S

$\varepsilon_L(\Theta_{Pmax})$: linearity error for Θ_{Pmax}

This model is valid for primary ampere-turns Θ_p between $-\Theta_{Pmax}$ and $+\Theta_{Pmax}$ only.

This is the absolute maximum error. As all errors are independent, a more realistic way to calculate the error would be to use the following formula:

Total error referred to primary

The total error ε_{tot} is the error at $\pm I_{PN}$, relative to the rated value

$$\varepsilon = \sqrt{\sum_{i=1}^N \varepsilon_i^2}$$

It includes all errors mentioned above

- the electrical offset I_{OE}
- the magnetic offset I_{OM}
- the sensitivity error ε_s
- the linearity error ε_L (to I_{PN}).

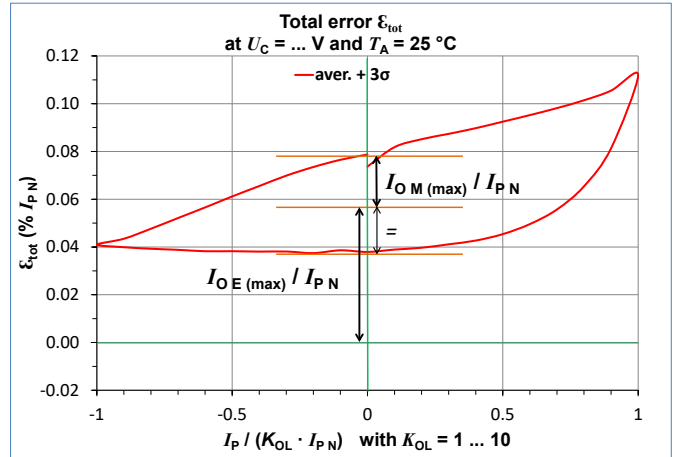

Figure 1 total error

Electrical offset referred to primary

Using the current cycle shown in figure 2, the electrical offset current I_{OE} is the residual output referred to primary when the input current is zero.

$$I_{OE} = \frac{I_{P(3)} + I_{P(5)}}{2}$$

The temperature variation I_{OT} of the electrical offset current I_{OE} is the variation of the electrical offset from 25 °C to the considered temperature.

$$I_{OT}(T) = I_{OE}(T) - I_{OE}(25^\circ\text{C})$$

Magnetic offset referred to primary

The magnetic offset current I_{OM} is the consequence of a current on the primary side ("memory effect" of the transducer's ferro-magnetic parts). It is measured using the following primary

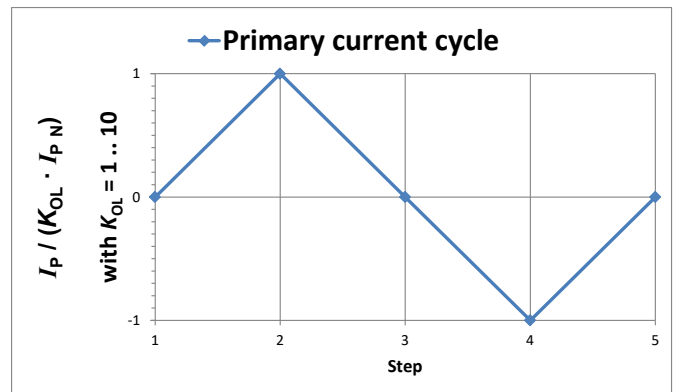

current cycle. I_{OM} depends on the current value $I_p \geq I_{PN}$.

K_{OL} : Overload factor

Figure 2: Current cycle used to measure magnetic and electrical offset (transducer supplied)

$$I_{OM} = \frac{I_{P(3)} - I_{P(5)}}{2}$$

Performance parameters definition

Sensitivity and linearity

To measure sensitivity and linearity, the primary current (DC) is cycled from 0 to I_P , then to $-I_P$ and back to 0 (equally spaced $I_P/10$ steps). The sensitivity S is defined as the slope of the linear regression line for a cycle between $\pm I_{PN}$.

The linearity error ϵ_L is the maximum positive or negative difference between the measured points and the linear regression line, expressed in % of I_{PN} .

Delay times

The delay time t_{D10} @ 10 % and the delay time t_{D90} @ 90 % with respect to the primary are shown in the next figure.

Both slightly depend on the primary current di/dt .

They are measured at nominal current.

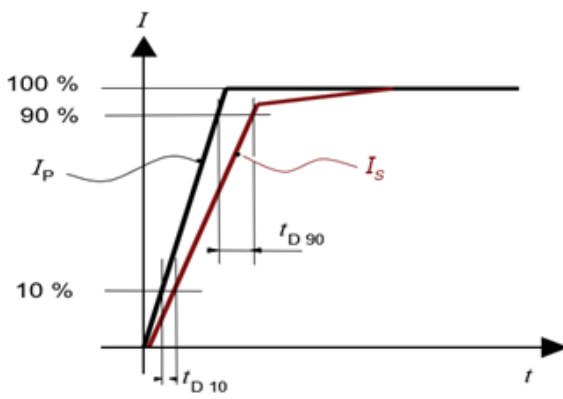
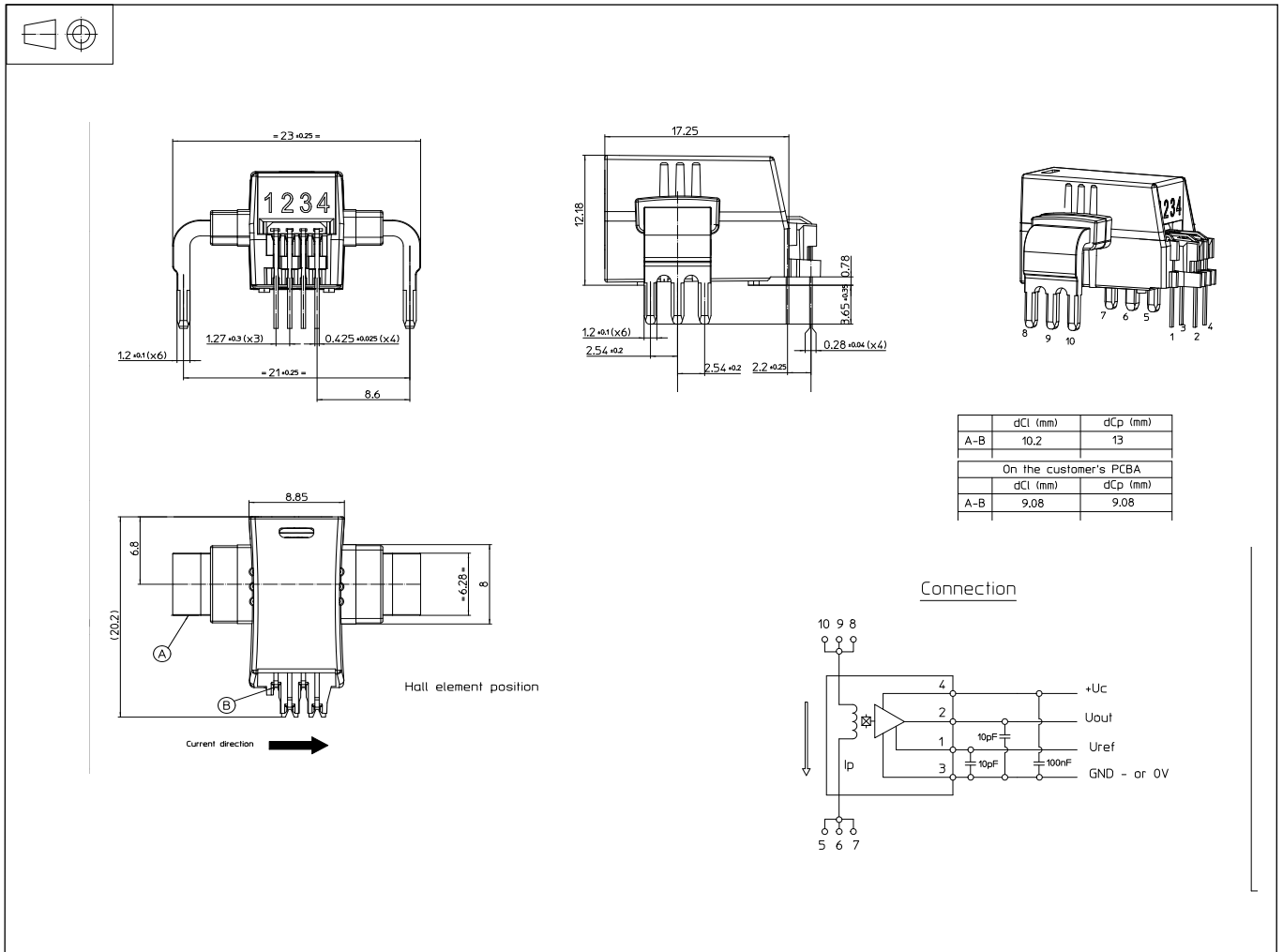

Figure 3: t_{D10} (delay time @ 10 %) and t_{D90} (delay time @ 90 %).

Dimensions (in mm)

Mechanical characteristics

- General tolerance ± 0.2 mm
- Color Black
- Busbar resistance@25°C ≤ 0.1 m Ω

Remarks

- I_s is positive when I_p flows in the direction of arrow.
- The secondary cables also have to be routed together all the way.
- Installation of the transducer must be done, unless otherwise specified on the datasheet, according to LEM Transducer Generic Mounting Rules. Please refer to LEM document N°ANE120504 available on our Web site: <https://www.lem.com/en/file/3137/download/>

IMPORTANT NOTICE

The information in this document is considered accurate and reliable. However, LEM International SA and any company directly or indirectly controlled by LEM Holding SA ("LEM") do not provide any guarantee or warranty, expressed or implied, regarding the accuracy or completeness of this information and are not liable for any consequences resulting from its use. LEM shall not be responsible for any indirect, incidental, punitive, special, or consequential damages (including, but not limited to, lost profits, lost savings, business interruption, costs related to the removal or replacement of products, or rework charges) regardless of whether such damages arise from tort (including negligence), warranty, breach of contract, or any other legal theory.

LEM reserves the right to update the information in this document, including specifications and product descriptions, at any time without prior notice. Information in this document replaces any previous versions of this document. No license to any intellectual property is granted by LEM through this document, either explicitly or implicitly. Any Information and product described herein is subject to export control regulations.

LEM products may possess either unidentified or documented vulnerabilities. It is the sole responsibility of the purchaser to design and operate their applications and products in a manner that mitigates the impact of these vulnerabilities. LEM disclaims any liability for such vulnerabilities. Customers must select products with security features that best comply with applicable rules, regulations, and standards for their intended use. The purchaser is responsible for making final design decisions regarding its products and for ensuring compliance with all legal, regulatory, and security-related requirements, irrespective of any information or support provided by LEM.

LEM products are not intended, authorized, or warranted for use in life support, life-critical, or safety-critical systems or equipment, nor in applications where failure or malfunction of an LEM product could result in personal injury, death, or significant property or environmental damage. LEM and its suppliers do not assume liability for the inclusion and/or use of LEM products in such equipment or applications; thus, this inclusion and/or use is at the purchaser's own and sole risk. Unless explicitly stated that a specific LEM product is automotive qualified, it should not be used in automotive applications. LEM does not accept liability for the inclusion and/or use of non-automotive qualified products in automotive equipment or applications.

Applications that are described herein are for illustrative purposes only. LEM makes no representation or warranty that LEM products will be suitable for a particular purpose, a specified use or application. The purchaser is solely responsible for the design and operation of its applications and devices using LEM products, and LEM accepts no liability for any assistance with any application or purchaser product design. It is purchaser's sole responsibility to determine whether the LEM product is suitable and fit for the purchaser's applications and products planned, as well as for the planned application and use of purchaser's third-party customer(s).

Stressing and using LEM products at or above limiting values will cause permanent damage to the LEM product and potentially to any device embedding or operating with LEM product. Limiting values are stress ratings only and operation of the LEM product at or above conditions and limits given in this document is not warranted. Continuous or repeated exposure to limiting values will permanently and irreversibly affect the quality and reliability of the LEM product.

LEM products are sold subject to the general terms and conditions of commercial sale, as published at www.lem.com unless otherwise agreed in a specific written agreement. LEM hereby expressly rejects the purchaser's general terms and conditions for purchasing LEM products by purchaser. Any terms and conditions contained in any document issued by the purchaser either before or after issuance of any document by LEM containing or referring to the general terms and conditions of sale are explicitly rejected and disregarded by LEM, and the document issued by the purchaser is wholly inapplicable to any sale or licensing made by LEM and is not binding in any way on LEM.

© 2025 LEM INTERNATIONAL SA – All rights reserved