

AUTOMOTIVE HYBRID CURRENT TRANSDUCER SHUNT AND OPEN LOOP HALL TECHNOLOGY HSU04

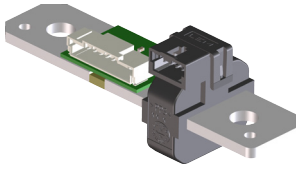

Introduction

The HSU is a hybrid current transducer for DC & AC measurement of the battery packs in electric and hybrid vehicles

HSU has 2 different current measurement channels: Shunt and hall effect.

Features

- High insulation level
- Unipolar +5 V DC power supply for HALL
- Primary current measuring range up to ± 2000 A (1 s) both Shunt and Hall
- Maximum RMS primary admissible current: defined by the busbar, the magnetic core or ASIC $T < +125$ °C
- Operating temperature range: -40 °C $< T < +125$ °C
- Output voltage: fully ratio-metric (in sensitivity and offset) for Hall effect channel.

Advantages

- Excellent accuracy
- Very good linearity
- Very low thermal offset drift
- Very low thermal sensitivity drift.

Automotive applications

- Battery management
- EV, Hybrid and utility vehicles
- The HSU Family is designed to run in a vehicle battery pack or in a Battery Disconnect Unit and cannot be used in an environment exposed to water projections or gravel projections. The HSU is compliant with Functional Safety standard ISO 26262. The test items used to validate the product are described at the end of the document
- The test items used to validate the product are described at the end of the document.

Principle of HSU - Shunt channel

There'll be a voltage drop when current goes through shunt, and current can be deduced by Ohm's Law, $I = U / R_{\text{Shunt}}$.

Principle of HSU - Hall effect channel

The open loop transducers use a Hall effect integrated circuit. The magnetic flux density B , contributing to the rise of the Hall voltage, is generated by the primary current I_p to be measured. The current to be measured I_p is supplied by a current source i.e. battery or generator (Figure 1). Within the linear region of the hysteresis cycle, B is proportional to:

$$B(I_p) = a \times I_p$$

The Hall voltage is thus expressed by:

$$U_{\text{Hall}} = (c_{\text{Hall}} / d) \times I_{\text{Hall}} \times a \times I_p$$

Except for I_p , all terms of this equation are constant. Therefore:

$$U_{\text{Hall}} = b \times I_p$$

a constant

b constant

c_{Hall} Hall coefficient

d thickness of the Hall plate

I_{Hall} current across the Hall plate

The measurement signal U_{Hall} is amplified to calculate the user output voltage or current.

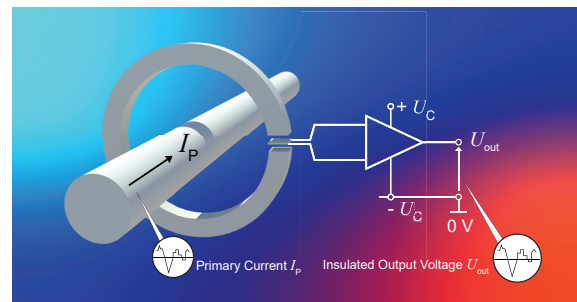
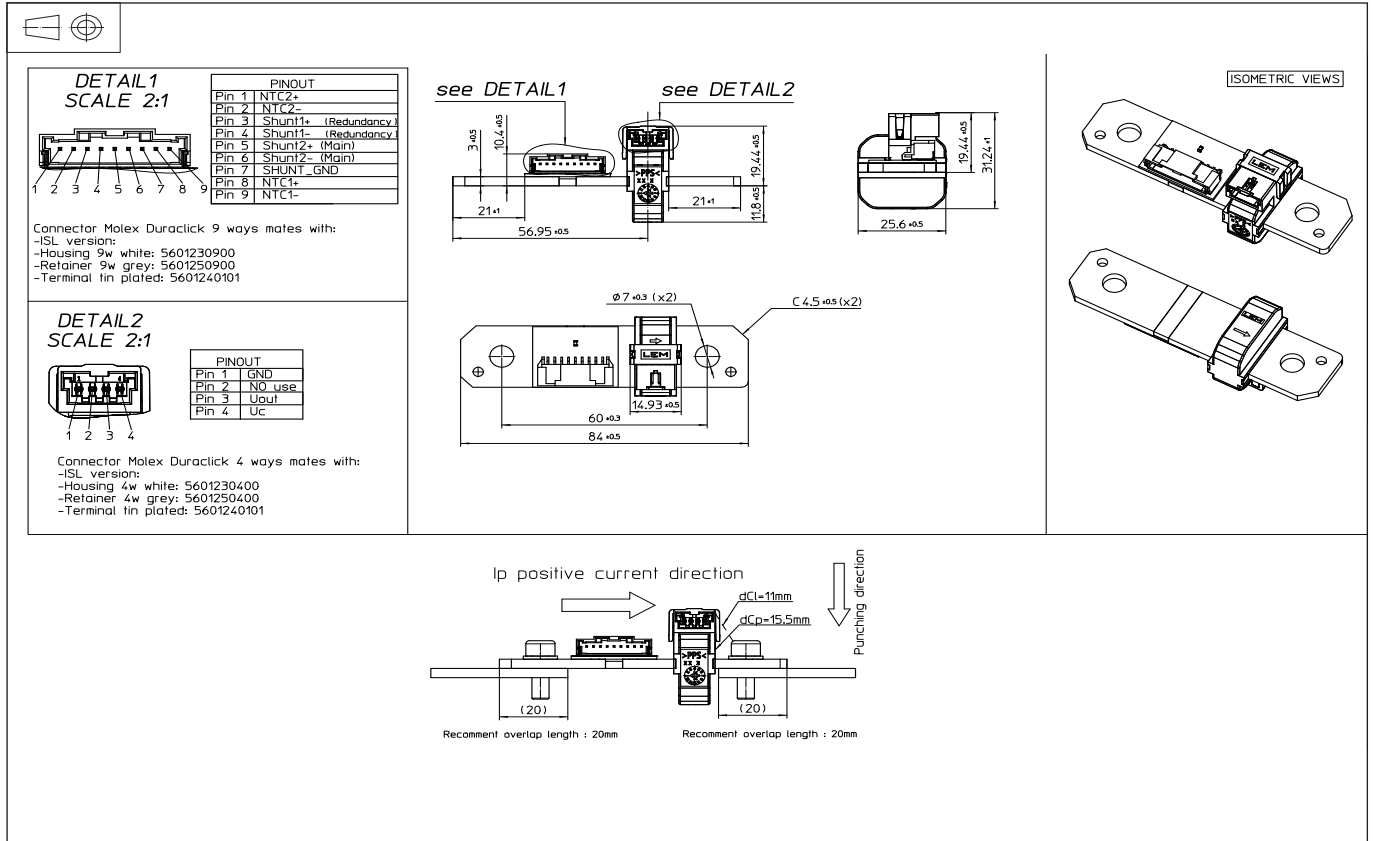

Fig. 1: Principle of the open loop transducer

Dimensions (in mm)

Mechanical characteristics

- Refer to Outline Drawing.

Mounting recommendation

- Assembly torque **M6 Screw with 8-10 N·m.**

Note: The installation planar should have a flatness tolerance of ≤ 0.2 mm. The size tolerances of the installation bracket and nut, as well as the use of installation tools and fixtures, have an impact on the maximum installation torque of the product. If there are any relevant design or process changes from customer side, it is advisable to implement them after verification.

Remark

- $U_{out} > U_O$ when I_p flows in the positive direction (see arrow on drawing).

NTC Simplified formula

$$T = 1 / \left(\ln \left(\frac{R_{NTC}}{10000} \right) / B + \frac{1}{273.15 + 25} \right) - 273.15$$

- Notes:**
- NTC type: NCU18XH103F6SRB
 - Main NTC is measured in Pin8 and Pin9
Redundancy NTC is measured in Pin1 and Pin2, currently reserved.

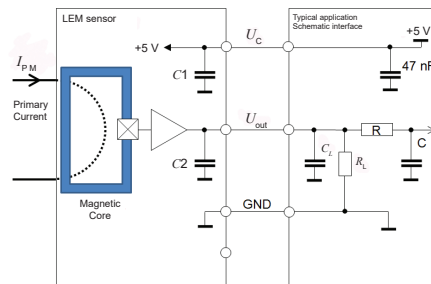
System architecture (Hall)

- $C_L < 100$ nF EMC protection (optional)
- $R_L \geq 10k$ Ohm
- RC Low pass filter (optional)

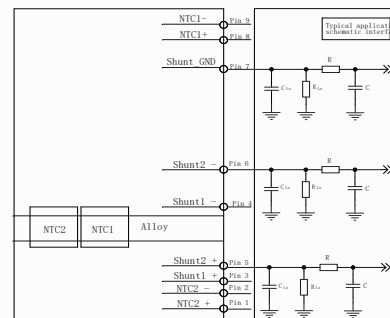
System architecture (Shunt)

- C_{LS} & R_{LS} Value is based on system design(optional)
- RC Low pass filter(Optional)

Absolute ratings (not operating)

Parameter	Symbol	Unit	Specification			Conditions
			Min	Typical	Max	
Maximum supply voltage	$U_{C\max}$	V	-14		14	Continuous, not operating
Ambient storage temperature	$T_{A\text{st}}$	°C	-40		125	
Electrostatic discharge voltage (HBM - Human Body Model)	$U_{\text{ESD HBM}}$	kV			8	
RMS voltage for AC insulation test	U_d	kV			4.2	50 HZ, 1 min, IEC 60664 part1
Creepage distance	d_{Cp}	mm	15.5			
Clearance	d_{Cl}	mm	11			
Comparative tracking index	CTI	-	PLC3			
Maximum output current	$I_{\text{out max}}$	mA	-10		10	
Maximum output voltage	$U_{\text{out max}}$	V	-14		14	
Insulation resistance	R_{INS}	MΩ	500			

Operating characteristics in nominal range (I_{PN}) For SHUNT

Parameter	Symbol	Unit	Specification			Conditions
			Min	Typical	Max	
Resistance value	R	μΩ	47.5		52.5	@ 25 °C
Temperature coefficient of resistance	a_R	PPM/°C	-200		200	@ 25 ~ 125 °C
Operating temperature	T	°C	-40		125	Based on NTC temperature

Note: ¹⁾ Definition of resistance tolerance is measured between Pin5 and Pin6
Resistance value between Pin3 and Pin4 is for reference only.

Operating characteristics in nominal range (I_{PN}) FOR HALL

Parameter	Symbol	Unit	Specification			Conditions
			Min	Typical	Max	
Electrical Data						
Supply voltage	U_C	V	4.75	5	5.25	
Ambient operating temperature	T_A	°C	-40		125	
Output voltage (Analog) ¹⁾	U_{out}	V	$U_{\text{out}} = (U_C / 5) \times (U_O + S \times I_P)$			
Offset voltage	U_O	V		2.5		@ $U_C = 5\text{ V}$
Current consumption	I_C	mA		15		@ $U_C = 5\text{ V}$, @ $T_A = 25\text{ °C}$, @ $I_P = 0\text{ A}$
Load resistance	R_L	KΩ	10			
Output internal resistance	R_{out}	Ω		1	10	
Performance Data						
Ratiometricity error	ε_r	%		±0.3		@ $T_A = 25\text{ °C}$
Sensitivity error	ε_S	%		±1		@ $T_A = 25\text{ °C}$, @ $U_C = 5\text{ V}$
Electrical offset voltage	U_{OE}	mV		±3		@ $T_A = 25\text{ °C}$, @ $U_C = 5\text{ V}$
Magnetic offset voltage	U_{OM}	mV		±1		@ $T_A = 25\text{ °C}$, @ $U_C = 5\text{ V}$
Average temperature coefficient of U_{OE}	TCU_{OEAV}	mV/°C		±0.04		@ $-40\text{ °C} < T_A < 125\text{ °C}$
Average temperature coefficient of S	TCS_{AV}	%/°C	-0.03	±0.01	0.03	@ $-40\text{ °C} < T_A < 125\text{ °C}$
Linearity error	ε_L			±1		@ $U_C = 5\text{ V}$, @ $T_A = 25\text{ °C}$
Frequency bandwidth ²⁾	BW	Hz		35		@ -3 dB
Peak-to-peak noise voltage	$U_{\text{no pp}}$	mV		10		@ DC to 1 MHz
Output RMS noise voltage	U_{no}	mV		1.5		@ DC to 1 MHz
Start-up time	t_{start}	ms			1	
Settling time after overload	t_s	ms			10	

Notes: ¹⁾ The output voltage U_{out} is fully ratiometric. The offset and sensitivity are dependent on the supply voltage U_C relative to the following formula:

$$I_P = \left(\frac{5}{U_C} \times U_{\text{out}} - U_O \right) \times \frac{1}{S} \text{ with } S \text{ in (V/A)}$$

²⁾ Primary current frequencies must be limited in order to avoid excessive heating of the busbar, magnetic core and the ASIC (see feature paragraph in page 1).

SHUNT

Parameter	Symbol	Unit	Specification			Conditions
			Min	Typical	Max	
Electrical Data						
Primary current, measuring range	I_{PM}	A	-2000		2000	Duration $\leq 1\text{ s}^{1)}$
Primary nominal RMS current	I_{PN}	A	-400		400	

HALL

Parameter	Symbol	Unit	Specification			Conditions
			Min	Typical	Max	
Electrical Data						
Primary current, measuring range	I_{PM}	A	-2000		2000	
Sensitivity	S	mV/A		1		@ $U_c = 5\text{ V}$

Care note for storage

The shunt current module shall be stored in an environment where temperature and humidity must be controlled (temperature 5 °C to 35 °C, humidity < 60 % RH) . However, the humidity should be maintained as low as possible.

Note: ¹⁾ Shunt alloy will be oxidized at an accelerated rate under high current >1s or temperature over 125 °C

Total error ϵ_{tot} HALL

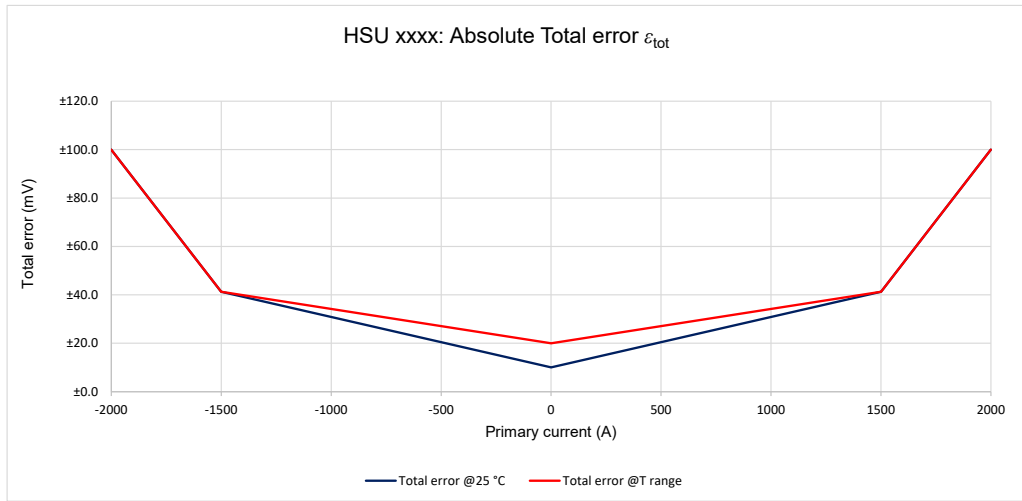

Primary current (A)	Total error @ 25 °C			Total error @ T range		
	(mV)	A	(%) $I_{PM}^{1)}$	(mV)	(A)	(%) $I_{PM}^{1)}$
-2000	100	100	5.00 %	100	100	5.00 %
-1500	41.25	41.25	2.06 %	41.25	41.25	2.06 %
0	10	10	-	20	20	-
1500	41.25	41.25	2.06 %	41.25	41.25	2.06 %
2000	100	100	5.00 %	100	100	5.00 %

Note: ¹⁾ Hall channel accuracy calculated by I_{PM} .

Derating curve

Setup

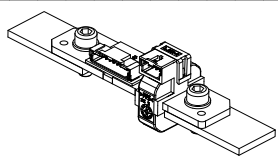
<p>Condition</p> <ul style="list-style-type: none"> - Inside climate chamber - 25 °C setting up in chamber - Test cable: copper(150mm²) - Mounting: refers to picture - Test points: alloy 	<p>HSU:</p> <ul style="list-style-type: none"> - Cu-OF - Section: 3 x 20 (mm) - Length: 84 mm 
--	---

Heating generation chart according to above condition

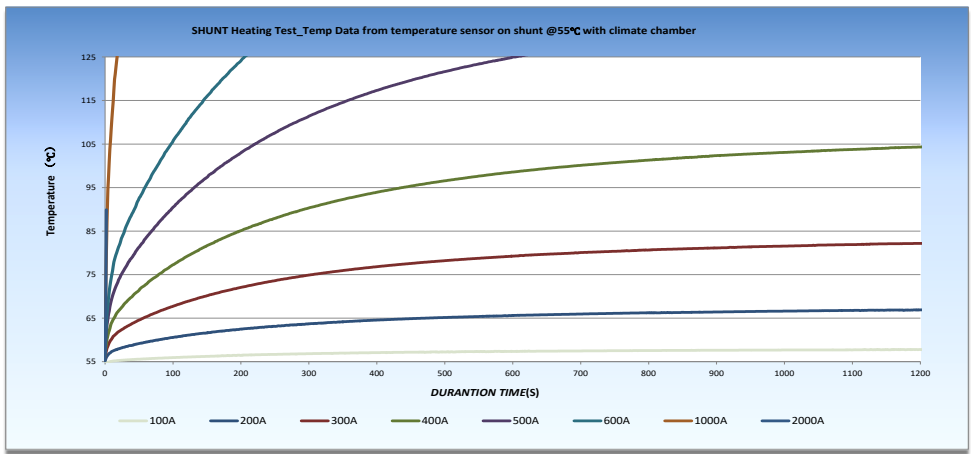

Notes: Depending on the conditions of use, the temperature of the exposed parts of Shunt alloy may reach or exceed 125°C.

DATA CODE & 2D Matrix Code

NOTE1
 DATECODE: PYYDDCCHHMMSSJ
 P= Product center
 YY= Year
 DDD= Day of Year
 CC= Code machine
 HH= Hour
 MM= Minute
 SS= Second
 J= Jig number

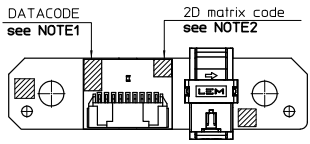

NOTE2

Module Info.	PCBA Part No(11 digits)	xxxxxxxxxxx
	Version(3 digits)	xxx
	Production date(6 digits)	YYMMDD
	Production Number(5 digits)	XXXXX
Shunt Info.	Year(4 digits)	YYYY
	Month(2 digits)	MM
	Day(2 digits)	DD
	Module ID(5 digits)	XXXXX
	Resistance R25(7 digits)	Rxxxxxn
	A Quadratic coefficient(12 digits)	+x.xxxxxxxxxxx
	B First-order coefficient(12 digits)	+x.xxxxxxxxxxx
	C Constant(12 digits)	+x.xxxxxxxxxxx

* R25 is shunt resistance at 25°C, unit: mOhm

Shunt Temperature Compensation information

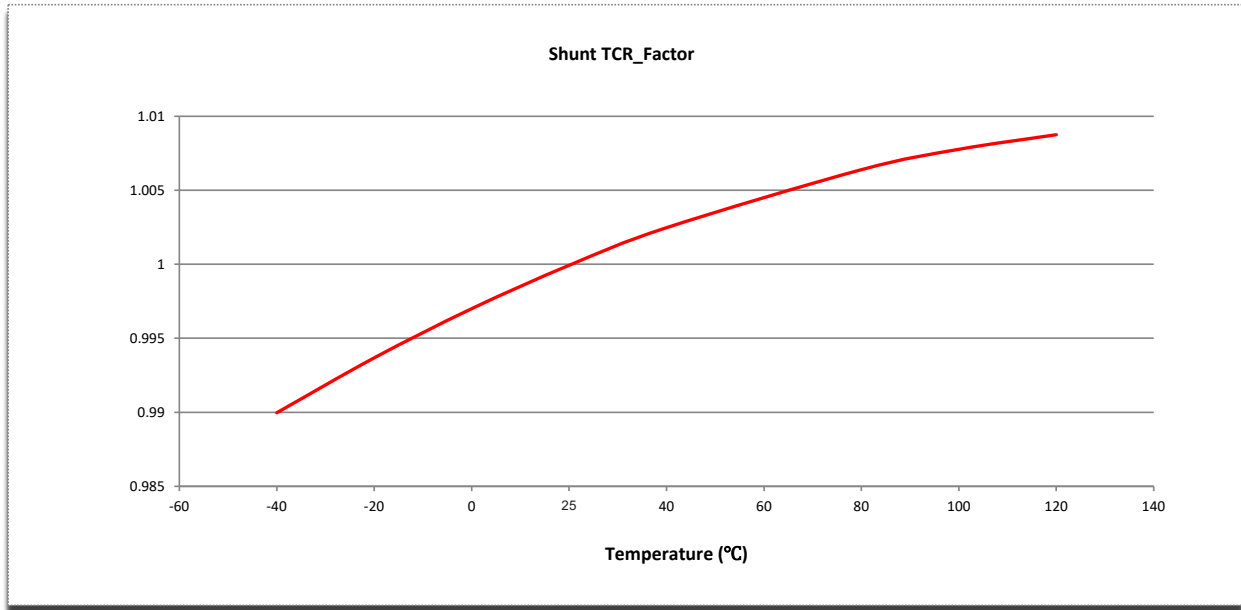

Generic compensation factor for resistance of shunt need to be multiplied with:

$$R_{temp} = R_{25} * (A * T^2 + B * T + C).$$

Where:

R_{temp} is the compensated from the factor for shunt resistance drift over temperature normalized to 1 at 25 °C.

T is temperature reading from PCB temperature transducer NTC.

A is quadratic coefficient, the default value is -0.xxxxxxxxxx.

B is first-order coefficient, the default value is +0.xxxxxxxxxx.

C constant term coefficient, the default value is +0.xxxxxxxxxx.

R_{25} is resistance value of shunt at 25 °C.

Functional Safety

Functional Safety Functional Safety Top Level Safety Requirement

HSU (Hall effect channel) – SR1 Current sensor error

Item1	Definitions
LEM Description	The sensor shall provide a valid current measurement value when the error versus the target value is lower than 10 %. The sensor accuracy error is below 5 % in the current ranges: [-2000 A; -1500 A [and] +1500 A; +2000 A]; in the current range [-1500 A; +1500 A] with an error below 2.75 %, and with offset less than 20 mV when $I_p = 0$.
ASIL	A(D)
Operation Conditions	Running (when sensor is supplied)
FHTI	Less than 20ms ⁽¹⁾
Safe state	No sensor internal safe state for accuracy error only for internal integrity failure ⁽²⁾

(1) Detailed Note for FHTI:
 5ms in case of Power supply failure
 Immediate in case of Memory failure
 20ms in case of Broken Supply Wire or ADC Output Clipping

(2) Note for Safe state
Power supply failure: Sensor Output value set to GND (external pull-down resistor required)
Memory Failure: Sensor output value goes to (0~0.2)%* U_C or (96~100)%* U_C . [U_C shall be within [4.75V, 5.25V].]
Broken Supply Wire: Sensor output goes to $V = (500nA \text{ Max}) * RL$. [RL shall be no less than 10Kohm.][All temperature range with $U_C = 5V$]
ADC Output Clipping: Sensor output value goes to (0~0.2)%* U_C or (96~100)%* U_C .

PERFORMANCES PARAMETERS DEFINITIONS

Primary current definition:

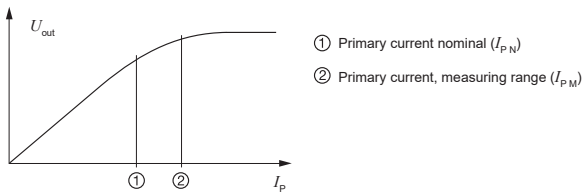

Definition of typical, minimum and maximum values:

Minimum and maximum values for specified limiting and safety conditions have to be understood as such as values shown in “typical” graphs. On the other hand, measured values are part of a statistical distribution that can be specified by an interval with upper and lower limits and a probability for measured values to lie within this interval. Unless otherwise stated (e.g. “100 % tested”), the LEM definition for such intervals designated with “min” and “max” is that the probability for values of samples to lie in this interval is 99.73 %. For a normal (Gaussian) distribution, this corresponds to an interval between -3 sigma and +3 sigma. If “typical” values are not obviously mean or average values, those values are defined to delimit intervals with a probability of 68.27 %, corresponding to an interval between -sigma and +sigma for a normal distribution. Typical, minimum and maximum values are determined during the initial characterization of a product.

Output noise voltage:

The output voltage noise is the result of the noise floor of the Hall elements and the linear amplifier.

Magnetic offset:

The magnetic offset is the consequence of an any current on the primary side. It's defined after a stated excursion of primary current.

Linearity:

The maximum positive or negative discrepancy with a reference straight line $U_{out} = f(I_p)$.
Unit: linearity (%) expressed with full scale of I_{pN} .

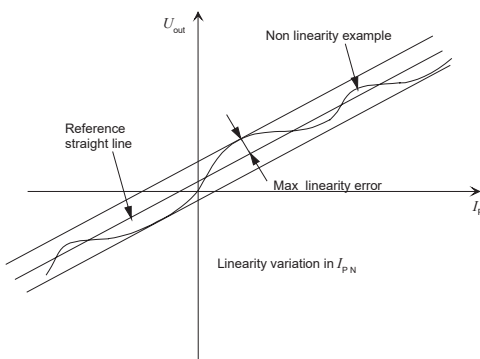

Delay time t_{D90} :

The time between the primary current signal (I_{pN}) and the output signal reach at 90 % of its final value.

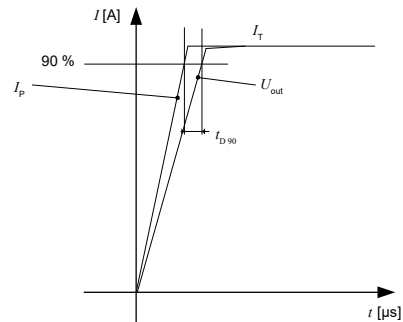

Sensitivity:

The transducer's sensitivity S is the slope of the straight line $U_{out} = f(I_p)$, it must establish the relation:

$$U_{out}(I_p) = U_c / 5 (S \times I_p + U_o)$$

Offset with temperature:

The error of the offset in the operating temperature is the variation of the offset in the temperature considered with the initial offset at 25 °C.

The offset variation I_{OT} is a maximum variation the offset in the temperature range:

$$I_{OT} = I_{OE} \max - I_{OE} \min$$

The offset drift TCI_{OEAV} is the I_{OT} value divided by the temperature range.

Sensitivity with temperature:

The error of the sensitivity in the operating temperature is the relative variation of sensitivity with the temperature considered with the initial offset at 25 °C.

The sensitivity variation S_T is the maximum variation (in ppm or %) of the sensitivity in the temperature range: $S_T = (\text{Sensitivity max} - \text{Sensitivity min}) / \text{Sensitivity at } 25 \text{ } ^\circ\text{C}$.

The sensitivity drift TCS_{AV} is the S_T value divided by the temperature range. Deeper and detailed info available is in our LEM technical sales offices (www.lem.com).

Offset voltage @ $I_p = 0 \text{ A}$:

The offset voltage is the output voltage when the primary current is zero. The ideal value of U_o is $U_c / 2$. So, the difference of $U_o - U_c / 2$ is called the total offset voltage error. This offset error can be attributed to the electrical offset (due to the resolution of the ASIC quiescent voltage trimming), the magnetic offset, the thermal drift and the thermal hysteresis. Deeper and detailed info available is in our LEM technical sales offices (www.lem.com).

Verification Plan

Tests	Standard	Specific Conditions
ELECTRICAL PERFORMANCES		
Frequency bandwidth		$U_C = 5\text{ V}$, 30 Hz to 100 kHz; At 20 A peak
ENVIRONMENTAL TESTS (Climatic)		
Ageing 85 °C /93 % RH	IEC 60068-2-78 (2012)	$T = 85\text{ °C}$; RH = 85 %; Duration = 1000 h $U_C = 5\text{ V}$; $I_p = 0\text{ A}$; Monitoring each 60 min
Low temperature storage	ISO 16750-4 § 5.1.1.1 (04/2010)	$T = -40\text{ °C}$ Duration = 500 h
High temperature storage	ISO 16750-4 § 5.1.2.1 (04/2010)	$T = 125\text{ °C}$ Duration = 1000 h
Power temperature cycle test	ISO 16750-4 § 5.3.1 (04/2010)	30 cycles (240 h), $-40\text{ °C} / 125\text{ °C}$ Shunt: $I_p = 600\text{ A}$ ((30min each test, continue 10S)) Hall: $U_C = 5\text{ V}$, monitoring U_{out} @ 0 A ((30min each test))
Thermal shock	ISO 16750-4 § 5.3.2 (2023)	$T = -40\text{ °C} \& 125\text{ °C}$ Duration = 300 cycles 30 min/30 min $U_C = \text{NO power supply (unconnected) and No wiring harness}$
ENVIRONMENTAL TESTS (Mechanical)		
Random Vibration	ISO 16750-3 § 4.1.x (12/2012)	Temperature $-40\text{ °C} / 125\text{ °C}$ RMS acceleration 27.1 m/s ² , 10 to 1000 Hz
Mechanical Shocks	ISO 16750-3 § 4.2 (12/2012)	Pulse shape: half sine, 50 G, 6 ms 10 shocks per direction (total 60)
SAFETY - Insulation tests		
Insulation test	ISO 16750-2 § 4.11 (11/2012)	$T_A = 25\text{ °C}$ $U_d = 4.26\text{ kV RMS (50 Hz)}$ for 60 s
Insulation resistance	ISO 16750-2 § 4.12 (12/2012)	DC = 1000 V RMS (50 Hz) for 60 s Criteria: $\geq 500\text{ M Ohm}$
EMC TESTS		
Immunity to Electrostatic Discharges (Handling of devices)	ISO 10605 (07/2008)	Contact discharges: $\pm 4\text{ kV}$; Air discharges: $\pm 8\text{ kV}$ $U_C = 0$
Immunity to Radiated disturbances (ALSE)	ISO 11452-2 (2019)	$f = 400\text{ MHz}$ to 1 GHz; Level = 100 V/m (CW, AM 80 %) $f = 0.8\text{ GHz}$ to 2 GHz; Level = 70 V/m (CW, PM PRR = 217 Hz PD = 0.57 ms) $f = 1\text{ GHz}$ to 2 GHz; Level = 70 V/m (CW)
Immunity to Conducted disturbances (BCI)	ISO 11452-4 (12/2020)	$f = 1\text{ MHz}$ to 400 MHz
Emission Radiated (ALSE)	CISPR 25 § 6.5 (2021)	$f = 150\text{ kHz}$ to 6 GHz

IMPORTANT NOTICE

The information in this document is considered accurate and reliable. However, LEM International SA and any company directly or indirectly controlled by LEM Holding SA ("LEM") do not provide any guarantee or warranty, expressed or implied, regarding the accuracy or completeness of this information and are not liable for any consequences resulting from its use. LEM shall not be responsible for any indirect, incidental, punitive, special, or consequential damages (including, but not limited to, lost profits, lost savings, business interruption, costs related to the removal or replacement of products, or rework charges) regardless of whether such damages arise from tort (including negligence), warranty, breach of contract, or any other legal theory.

LEM reserves the right to update the information in this document, including specifications and product descriptions, at any time without prior notice. Information in this document replaces any previous versions of this document. No license to any intellectual property is granted by LEM through this document, either explicitly or implicitly. Any Information and product described herein is subject to export control regulations.

LEM products may possess either unidentified or documented vulnerabilities. It is the sole responsibility of the purchaser to design and operate their applications and products in a manner that mitigates the impact of these vulnerabilities. LEM disclaims any liability for such vulnerabilities. Customers must select products with security features that best comply with applicable rules, regulations, and standards for their intended use. The purchaser is responsible for making final design decisions regarding its products and for ensuring compliance with all legal, regulatory, and security-related requirements, irrespective of any information or support provided by LEM.

LEM products are not intended, authorized, or warranted for use in life support, life-critical, or safety-critical systems or equipment, nor in applications where failure or malfunction of an LEM product could result in personal injury, death, or significant property or environmental damage. LEM and its suppliers do not assume liability for the inclusion and/or use of LEM products in such equipment or applications; thus, this inclusion and/or use is at the purchaser's own and sole risk. Unless explicitly stated that a specific LEM product is automotive qualified, it should not be used in automotive applications. LEM does not accept liability for the inclusion and/or use of non-automotive qualified products in automotive equipment or applications.

Applications that are described herein are for illustrative purposes only. LEM makes no representation or warranty that LEM products will be suitable for a particular purpose, a specified use or application. The purchaser is solely responsible for the design and operation of its applications and devices using LEM products, and LEM accepts no liability for any assistance with any application or purchaser product design. It is purchaser's sole responsibility to determine whether the LEM product is suitable and fit for the purchaser's applications and products planned, as well as for the planned application and use of purchaser's third-party customer(s).

Stressing and using LEM products at or above limiting values will cause permanent damage to the LEM product and potentially to any device embedding or operating with LEM product. Limiting values are stress ratings only and operation of the LEM product at or above conditions and limits given in this document is not warranted. Continuous or repeated exposure to limiting values will permanently and irreversibly affect the quality and reliability of the LEM product.

LEM products are sold subject to the general terms and conditions of commercial sale, as published at www.lem.com unless otherwise agreed in a specific written agreement. LEM hereby expressly rejects the purchaser's general terms and conditions for purchasing LEM products by purchaser. Any terms and conditions contained in any document issued by the purchaser either before or after issuance of any document by LEM containing or referring to the general terms and conditions of sale are explicitly rejected and disregarded by LEM, and the document issued by the purchaser is wholly inapplicable to any sale or licensing made by LEM and is not binding in any way on LEM.

© 2025 LEM INTERNATIONAL SA – All rights reserved