

Current Transducer HTC 250 ... 4000-S/SP4

For the electronic measurement of currents: DC, AC, pulsed..., with galvanic separation between the primary circuit and the secondary circuit.

$$I_{PND C} = \pm 250 \dots 4000 \text{ A}$$



Electrical data

Primary nominal DC current (continuous) $I_{PND C}$ (A)	Primary current measuring range I_{PM} (A)	Type
250	±275	HTC 250-S/SP4
300	±330	HTC 300-S/SP4
500	±550	HTC 500-S/SP4
1000	±1100	HTC 1000-S/SP4
1500	±1650	HTC 1500-S/SP4
2000	±2200	HTC 2000-S/SP4
2500	±2750	HTC 2500-S/SP4
3000	±3300	HTC 3000-S/SP4
4000	±4400	HTC 4000-S/SP4

U_C	Supply voltage (±3 %)	±15	V
I_C	Current consumption	< ±20	mA
R_{INS}	Insulation resistance @ 500 V DC	> 500	MΩ
U_{out}	Output voltage (analog) @ ± $I_{PND C}$; $R_L = 2 \text{ k}\Omega$; $T_A = 25^\circ\text{C} \pm 10$		V
R_{out}	Output internal resistance	< 100	Ω
R_L	Load resistance	≥ 2	kΩ

Accuracy - Dynamic performance data

ε	Error @ $I_{PND C}$, $T_A = 25^\circ\text{C}$	< ±1	% of $I_{PND C}$
ε_L	Linearity error (0 ... ± $I_{PND C}$)	< ±1	% of $I_{PND C}$
U_{OE}	Electrical offset voltage @ $T_A = 25^\circ\text{C}$	< ±30	mV
U_{OM}	Magnetic offset voltage @ $U_{PN} = 0$ referred to primary after an excursion of $1 \times U_{PND C}$	< ±50	mV
TCU_{OE}	Temperature coefficient of U_{OE}	< ±1.0	mV/K
TCU_{out}	Temperature coefficient of U_{out}	< ±0.1	%/K
t_{D90}	Delay time to 90 % of the final output value for $I_{PND C}$ step ¹⁾ ≤ 10		μs
BW	Frequency bandwidth (-3 dB)	DC ... 10	kHz

General data

T_A	Ambient operating temperature	-40 ... +85	°C
T_{Ast}	Ambient storage temperature	-40 ... +85	°C
m	Mass Standard ²⁾	450	g
		EN 50155: 2007	

Notes: ¹⁾ For a $di/dt = 100 \text{ A}/\mu\text{s}$.

²⁾ Deviation of the offset during the test IEC 61000-4-3 @ 20 V/m in the ranges (80-250) MHz and (500-100) MHz.



Features

- Open loop current transducer using the Hall effect
- Insulating plastic case recognized according to UL 94-V0.

Special feature

- PbF RoHS

Advantages

- Easy installation
- Compact
- High immunity to external interference
- Low power consumption.

Applications

- AC variable speed drives and servo motor drives
- Static converters for DC motor drives
- Battery supplied applications
- Uninterruptible Power Supplies (UPS)
- Switched Mode Power Supplies (SMPS)
- Power supplies for welding applications.

Application Domain

- Railway (fixed installations and onboard).

Current Transducer HTC 250 ... 4000-S/SP4

Insulation coordination

U_d	RMS voltage for AC insulation test, 50 Hz, 1 min	2.5 Min	kV
d_{cp}	Creepage distance	> 15.1	mm
d_{ci}	Clearance	> 15.1	mm
CTI	Comparative tracking index (group IIIa)	275	

Safety

This transducer must be used in limited-energy secondary circuits according to IEC 61010-1.



This transducer must be used in electric/electronic equipment with respect to applicable standards and safety requirements in accordance with the manufacturer's operating instructions.



Caution, risk of electrical shock

When operating the transducer, certain parts of the module can carry hazardous voltage (e.g. primary busbar, power supply). Ignoring this warning can lead to injury and/or cause serious damage.

This transducer is a build-in device, whose conducting parts must be inaccessible after installation. A protective housing or additional shield could be used.

Main supply must be able to be disconnected.

Dimensions HTC 250 ... 4000-S/SP4 (in mm)

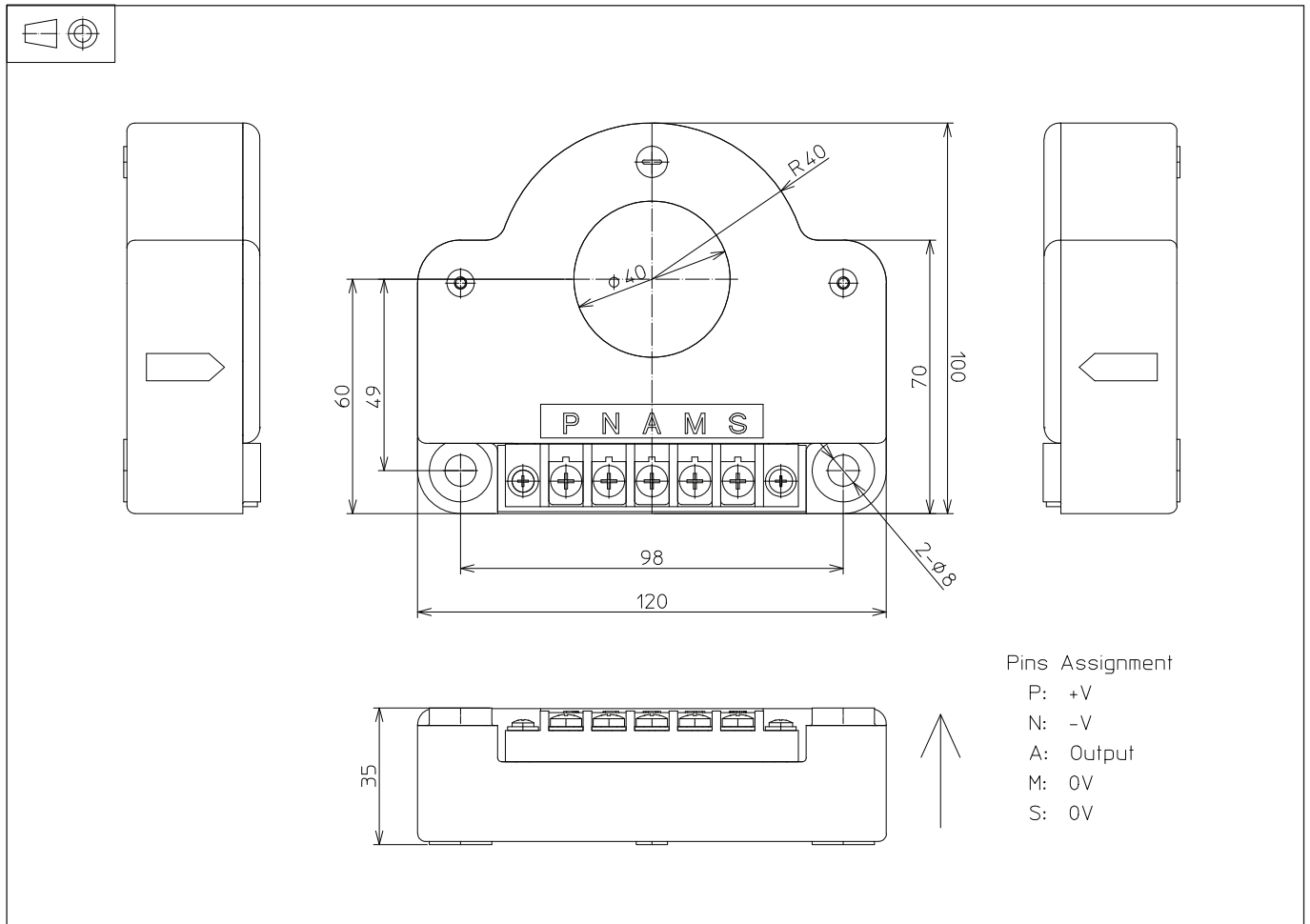

Connection circuit

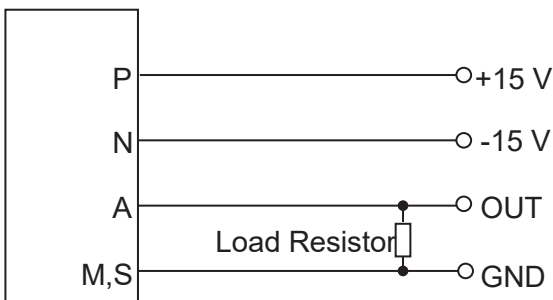

Operation principle

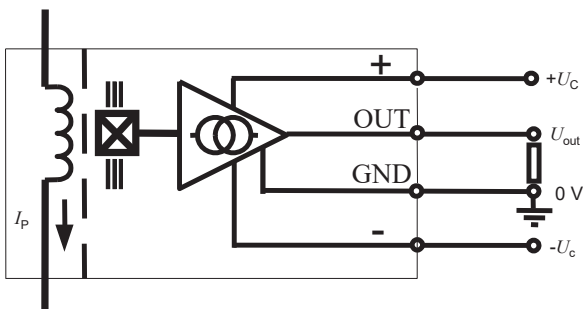

Mechanical characteristics

- General tolerance ± 1 mm
- Transducer fastening
Recommended fastening torque 2.6 ± 0.52 N·m

Remarks

- I_s is positive when I_p flows in the direction of the arrow.
- Temperature of the primary conductor should not exceed 100 °C.
- Installation of the transducer must be done unless otherwise specified on the datasheet, according to LEM Transducer Generic Mounting Rules. Please refer to LEM document N°ANE120504 available on our Web site:
<https://www.lem.com/en/file/3137/download/>.