

Current Transducer LA 125-P/SP1

For the electronic measurement of currents: DC, AC, pulsed..., with galvanic separation between the primary circuit and the secondary circuit.

$$I_{PN} = 125 \text{ A}$$

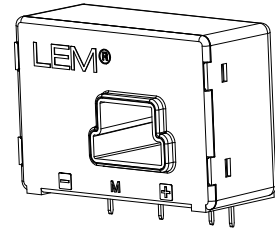

Electrical data

I_{PN}	Primary nominal current RMS	125	A				
I_{PM}	Primary current, measuring range	0 ... ± 200	A				
R_M	Measuring resistance	$T_A = 70^\circ\text{C}$		$T_A = 85^\circ\text{C}$			
		$R_{M \min}$	$R_{M \max}$	$R_{M \min}$	$R_{M \max}$		
		with $\pm 12 \text{ V}$	@ $\pm 125 \text{ A}_{\max}$	0	90	0	85
			@ $\pm 200 \text{ A}_{\max}$	0	30	0	25
		with $\pm 15 \text{ V}$	@ $\pm 125 \text{ A}_{\max}$	0	135	0	130
	@ $\pm 200 \text{ A}_{\max}$	0	55	0	50		
I_{SN}	Secondary nominal current RMS	62.5	mA				
N_P/N_S	Turns ratio	1 : 2000					
U_C	Supply voltage ($\pm 5\%$)	$\pm 12 \dots 15$	V				
I_C	Current consumption	$16 (@ \pm 15 \text{ V}) + I_S$	mA				

Accuracy - Dynamic performance data

ϵ	Error @ I_{PN} , $T_A = 25^\circ\text{C}$ @ $\pm 15 \text{ V}$ ($\pm 5\%$)	± 0.60	%	
		@ $\pm 12 \dots 15 \text{ V}$ ($\pm 5\%$)	± 0.80	%
ϵ_L	Linearity error	< 0.15	%	
I_{OE}	Electrical offset current @ $I_P = 0$, $T_A = 25^\circ\text{C}$	Typ	Max	
			± 0.20	mA
I_{OM}	Magnetic offset current ¹⁾ @ $I_P = 0$ and specified R_M , after an overload of $3 \times I_{PN}$	± 0.25	mA	
I_{OT}	Temperature variation of I_O	0 $^\circ\text{C}$... +70 $^\circ\text{C}$	± 0.10	mA
		-25 $^\circ\text{C}$... +85 $^\circ\text{C}$	± 0.10	mA
			± 0.25	mA
t_{D10}	Delay time to 10 % of the final output value for I_{PN} step	< 500	ns	
t_{D90}	Delay time to 90 % of the final output value for I_{PN} step ²⁾³⁾	< 1	μs	
BW	Frequency bandwidth ³⁾ (-1 dB)	DC ... 100	kHz	

General data

T_A	Ambient operating temperature	-25 ... +85	$^\circ\text{C}$
T_{Ast}	Ambient storage temperature	-40 ... +90	$^\circ\text{C}$
R_S	Secondary coil resistance	@ $T_A = 70^\circ\text{C}$	76
		@ $T_A = 85^\circ\text{C}$	80
m	Mass	40	g
	Standard	EN 50178: 1997	

Notes: ¹⁾ Result of the coercive field of the magnetic circuit

²⁾ With a di/dt of 100 A/ μs

³⁾ The primary conductor is best filling the through-hole and/or the return of the primary conductor is above the top of the transducer.

Features

- Closed loop (compensated) current transducer using the Hall effect
- Insulating plastic case recognized according to UL 94-V0.

Special feature

- $N_P/N_S = 1 : 2000$.

Advantages

- Excellent accuracy
- Very good linearity
- Low temperature drift
- Optimized response time
- Wide frequency bandwidth
- No insertion losses
- High immunity to external interference
- Current overload capability.

Applications

- AC variable speed drives and servo motor drives
- Static converters for DC motor drives
- Battery supplied applications
- Uninterruptible Power Supplies (UPS)
- Switched Mode Power Supplies (SMPS)
- Power supplies for welding applications.

Application domain

- Industrial.

Current Transducer LA 125-P/SP1

Insulation characteristics

U_d	RMS voltage for AC insulation test, 50 Hz, 1 min	3	kV
U_{Ni}	Impulse withstand voltage 1.2/50 μ s	7	kV
		Min	
d_{cp}	Creepage distance	6.7	mm
d_{cl}	Clearance	6.7	mm
CTI	Comparative Tracking Index (group IIIa)	175	

Applications examples

According to EN 50178 and IEC 61010-1 standards and following conditions:

- Over voltage category OV 3
- Pollution degree PD2
- Non-uniform field

	EN 50178	IEC 61010-1
d_{cp}, d_{cl}, U_{Ni}	Rated insulation voltage	Nominal voltage
Basic insulation	600 V	600 V
Reinforced insulation	300 V	300 V

Safety

This transducer must be used in limited-energy secondary circuits according to IEC 61010-1.



This transducer must be used in electric/electronic equipment with respect to applicable standards and safety requirements in accordance with the manufacturer's operating instructions.



Caution, risk of electrical shock

When operating the transducer, certain parts of the module can carry hazardous voltage (eg. primary busbar, power supply).

Ignoring this warning can lead to injury and/or cause serious damage.

This transducer is a build-in device, whose conducting parts must be inaccessible after installation.

A protective housing or additional shield could be used.

Main supply must be able to be disconnected.

Dimensions LA 125-P/SP1 (in mm)

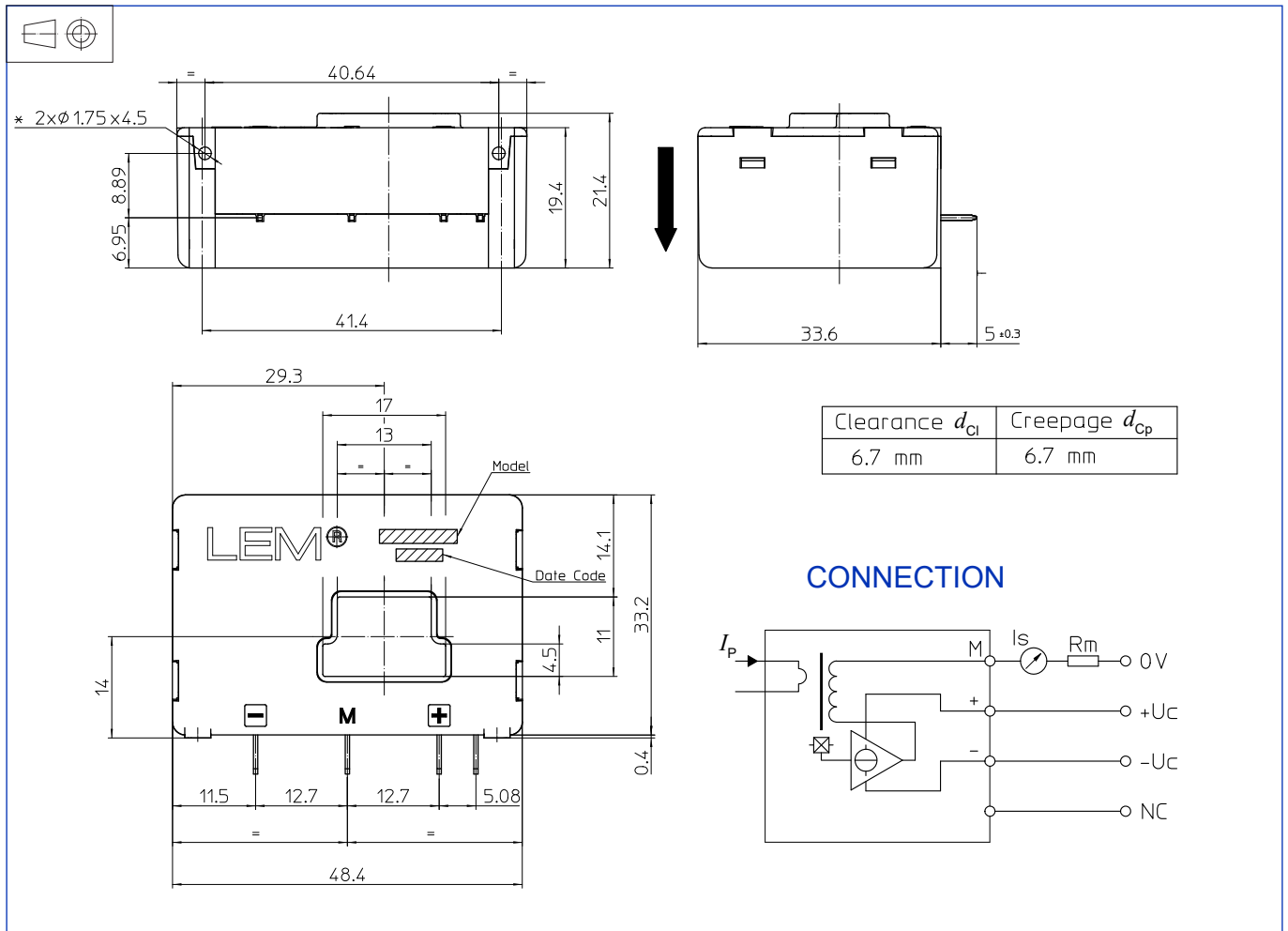

Mechanical characteristics

- General tolerance ± 0.2 mm
- Primary through-hole 17 x 4.5 mm or 13 x 11 mm
- Fastening & connection of secondary 4 pins 0.63 x 0.56 mm
Recommended PCB hole 0.9 mm
- Supplementary fastening 2 holes Ø 1.75 mm
Recommended PCB hole 2.4 mm
Recommended screws PT KA 22 x 6
Recommended fastening torque 0.5 N·m

Remarks

- I_s is positive when I_p flows in the direction of the arrow.
- Temperature of the primary conductor should not exceed 100 °C.
- Dynamic performances (di/dt and delay time) are best with a single bar completely filling the primary hole.
- Installation of the transducer must be done unless otherwise specified on the datasheet, according to LEM Transducer Generic Mounting Rules. Please refer to LEM document N°ANE120504 available on our Web site: <https://www.lem.com/en/file/3137/download/>.