

Current Transducer LF 1005-S/SP22

For the electronic measurement of currents: DC, AC, pulsed..., with galvanic separation between the primary circuit and the secondary circuit.

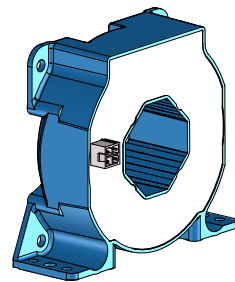

$I_{PN} = 1000 \text{ A}$



Electrical data

I_{PN}	Primary nominal RMS current	1000	A				
I_{PM}	Primary current, measuring range @ $\pm 24 \text{ V}$	0 ... ± 1500	A				
R_M	Measuring resistance @	$T_A = 70 \text{ }^\circ\text{C}$		$T_A = 85 \text{ }^\circ\text{C}$			
		$R_{M \min}$	$R_{M \max}$	$R_{M \min}$	$R_{M \max}$	Ω	
		with $\pm 15 \text{ V}$	@ $\pm 1000 \text{ A}_{\max}$	0	23	0	20
			@ $\pm 1200 \text{ A}_{\max}$	0	12	0	9
		with $\pm 24 \text{ V}$	@ $\pm 1000 \text{ A}_{\max}$	10	65	15	62
	@ $\pm 1500 \text{ A}_{\max}$	10	29	15	26		
I_{SN}	Secondary nominal RMS current	200	mA				
N_P/N_S	Turns ratio	1 : 5000					
U_C	Supply voltage ($\pm 5 \%$)	15 ... ± 24	V				
I_C	Current consumption	28 (@ $\pm 24 \text{ V}$) + I_S	mA				

Accuracy - Dynamic performance data

ϵ_{tot}	Total error @ I_{PN} , $T_A = 25 \text{ }^\circ\text{C}$	± 0.4	%
ϵ_L	Linearity error	< 0.1	%
I_O	Offset current @ $I_P = 0$, $T_A = 25 \text{ }^\circ\text{C}$	Typ	Max
		± 0.1	± 0.4
I_{OT}	Temperature variation of I_O	-10 $^\circ\text{C}$... +85 $^\circ\text{C}$	± 0.3 ± 0.5
		-40 $^\circ\text{C}$... +85 $^\circ\text{C}$	± 0.5 ± 0.8
t_{D90}	Delay time to 90 % of the final output value for I_{PN} step ¹⁾	< 1	μs
BW	Frequency bandwidth (-1 dB)	DC ... 150	kHz

General data

T_A	Ambient operating temperature	-40 ... +85	$^\circ\text{C}$
$T_{A \text{ st}}$	Ambient storage temperature	-40 ... +100	$^\circ\text{C}$
R_S	Resistance of secondary winding @	$T_A = 70 \text{ }^\circ\text{C}$	43 Ω
		$T_A = 85 \text{ }^\circ\text{C}$	46 Ω
m	Mass	550	g
	Standard	EN 50178: 1997	

Note: ¹⁾ With a di/dt of 100 A/ μs .

Features

- Closed loop (compensated) current transducer using the Hall effect
- Insulating plastic case recognized according to UL 94-V0.

Special features

- $T_A = -40 \text{ }^\circ\text{C}$... +85 $^\circ\text{C}$
- Secondary connection on Molex Mini-Fit Jr. 5566 Gold plated pins or equivalent.

Advantages

- Excellent accuracy
- Very good linearity
- Low temperature drift
- Optimized response time
- Wide frequency bandwidth
- No insertion losses
- High immunity to external interference
- Current overload capability.

Applications

- AC variable speed drives and servo motor drives
- Static converters for DC motor drives
- Battery supplied applications
- Uninterruptible Power Supplies (UPS)
- Switched Mode Power Supplies (SMPS)
- Power supplies for welding applications.

Application domain

- Industrial.

Current Transducer LF 1005-S/SP22

Isolation characteristics

U_d	RMS voltage for AC insulation test, 50 Hz, 1 min	3	kV
U_{Ni}	Impulse withstand voltage 1.2/50 μ s	10.6	kV
		Min	
d_{Cp}	Creepage distance	33.2	mm
d_{Ci}	Clearance	14.7	mm
CTI	Comparative tracking index (group IIIa)	175	

Applications examples

According to EN 50178 and IEC 61010-1 standards and following conditions:

- Over voltage category OV 3
- Pollution degree PD2
- Non-uniform field

	EN 50178	IEC 61010-1
d_{Cp}, d_{Ci}, U_{Ni}	Rated insulation voltage	Nominal voltage
Basic insulation	1250 V	1250 V
Reinforced insulation	630 V	630 V

Safety

This transducer must be used in limited-energy secondary circuits according to IEC 61010-1.



This transducer must be used in electric/electronic equipment with respect to applicable standards and safety requirements in accordance with the manufacturer's operating instructions.



Caution, risk of electrical shock

When operating the transducer, certain parts of the module can carry hazardous voltage (eg. primary busbar, power supply).

Ignoring this warning can lead to injury and/or cause serious damage.

This transducer is a build-in device, whose conducting parts must be inaccessible after installation.

A protective housing or additional shield could be used.

Main supply must be able to be disconnected.

Dimensions LF 1005-S/SP22 (in mm)

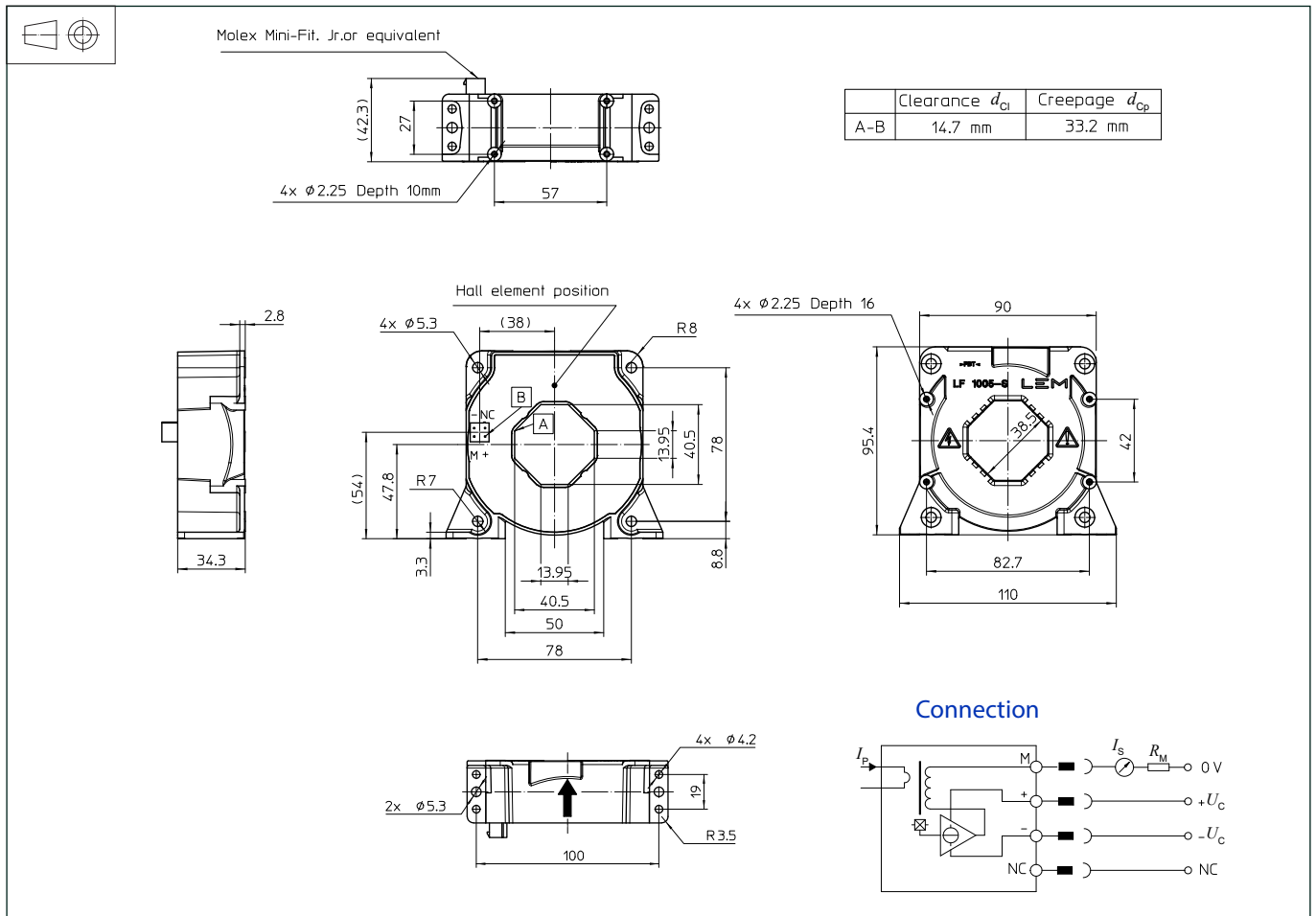

Mechanical characteristics

- General tolerance ± 0.5 mm
- Transducer fastening
 - Vertical position
 - 2 holes $\varnothing 5.3$ mm
 - 2 M5 steel screws
 - Recommended fastening torque 4 N·m
 - or
 - 4 holes $\varnothing 4.2$ mm
 - 4 M4 steel screws
 - Recommended fastening torque 3.2 N·m
 - or
 - 4 holes $\varnothing 2.25$ mm
 - depth: 10 mm
 - 4 × PTKA 30 screws
 - Recommended fastening torque 0.9 N·m
 - Horizontal position
 - 4 holes $\varnothing 5.3$ mm
 - 4 M5 steel screws
 - Recommended fastening torque 4 N·m
 - or
 - 4 holes $\varnothing 2.25$ mm
 - depth: 16 mm
 - 4 × PTKA 30 screws
 - Recommended fastening torque 1 N·m

- Primary through-hole 40.5 × 13 mm or $\varnothing 38$ mm
- Connection of secondary Molex Mini-Fit Jr. 5566 - gold-plated pins or equivalent
- Recommended mating connector Molex Mini-Fit Jr. 5557 series.

Remarks

- I_s is positive when I_p flows in the direction of the arrow.
- Temperature of the primary conductor should not exceed 100 °C.
- Dynamic performances (di/dt and delay time) are best with a single bar completely filling the primary hole.