

Current Transducer LTC 350-S

For the electronic measurement of currents: DC, AC, pulsed..., with galvanic separation between the primary circuit and the secondary circuit.

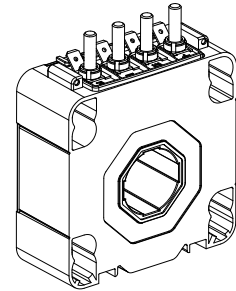

$$I_{PN} = 350 \text{ A}$$



Electrical data

I_{PN}	Primary nominal RMS current	350	A			
I_{PM}	Primary current, measuring range @ $\pm 24 \text{ V}$	0 ... ± 1200	A			
R_M	Measuring resistance	$R_{M \min}$	$R_{M \max}$			
		with $\pm 15 \text{ V}$	@ $\pm 500 \text{ A}_{\max}$	0	30	Ω
			@ $\pm 900 \text{ A}_{\max}$	0	8	Ω
		with $\pm 24 \text{ V}$	@ $\pm 500 \text{ A}_{\max}$	10	60	Ω
	@ $\pm 1200 \text{ A}_{\max}$	10	17	Ω		
I_{SN}	Secondary nominal RMS current	175	mA			
N_P/N_S	Turns ratio	1 : 2000				
U_C	Supply voltage ($\pm 5 \%$)	$\pm 15 \dots 24$	V			
I_C	Current consumption	$< 35 (@ \pm 24 \text{ V}) + I_S$	mA			

Accuracy - Dynamic performance data

ϵ_{tot}	Total error @ $I_{PN}, T_A = 25 \text{ }^\circ\text{C}$	$< \pm 0.5$	%
ϵ_L	Linearity error	< 0.1	%
		Max	
I_O	Offset current @ $I_p = 0, T_A = 25 \text{ }^\circ\text{C}$	± 0.5	mA
I_{OT}	Temperature variation of I_O	$-40 \text{ }^\circ\text{C} \dots +85 \text{ }^\circ\text{C}$	± 0.8 mA
t_{D90}	Delay time to 90 % of the final output value for I_{PN} step ¹⁾	< 1	μs
BW	Frequency bandwidth (-1 dB)	DC ... 100	kHz

General data

T_A	Ambient operating temperature	$-40 \dots +85$	$^\circ\text{C}$
T_{Ast}	Ambient storage temperature	$-45 \dots +90$	$^\circ\text{C}$
R_S	Resistance of secondary winding @ $T_A = 85 \text{ }^\circ\text{C}$	15	Ω
m	Mass	400	g
	Standards	EN 50155: 2017 ²⁾ EN 50121-3-2: 2016	

Notes: ¹⁾ For a $di/dt = 100 \text{ A}/\mu\text{s}$
²⁾ Additional information available on request.

Features

- Closed loop (compensated) current transducer using the Hall effect
- Insulating plastic case recognized according to UL 94-V0.

Advantages

- Excellent accuracy
- Very good linearity
- Low temperature drift
- Optimized response time
- Wide frequency bandwidth
- No insertion losses
- High immunity to external interference
- Current overload capability.

Applications

- Single or three phase inverter
- Propulsion and braking chopper
- Propulsion converter
- Auxiliary converter
- Battery charger.

Application Domain

- Railway (fixed installations and onboard).

Current Transducer LTC 350-S

Insulation coordination

U_d	RMS voltage for AC insulation test, 50 Hz, 1 min	12 ¹⁾	kV
		1.5 ²⁾	kV
		Min	
d_{cp}	Creepage distance	50	mm
d_{cl}	Clearance	44	mm
CTI	Comparative tracking index (group I)	600	

Notes: ¹⁾ Between primary and secondary + shield
²⁾ Between secondary and shield.

Safety

This transducer must be used in limited-energy secondary circuits according to IEC 61010-1.



This transducer must be used in electric/electronic equipment with respect to applicable standards and safety requirements in accordance with the manufacturer’s operating instructions.



Caution, risk of electrical shock

When operating the transducer, certain parts of the module can carry hazardous voltage (eg. primary busbar, power supply).
 Ignoring this warning can lead to injury and/or cause serious damage.
 This transducer is a build-in device, whose conducting parts must be inaccessible after installation.
 A protective housing or additional shield could be used.
 Main supply must be able to be disconnected.

Dimensions LTC 350-S (in mm)

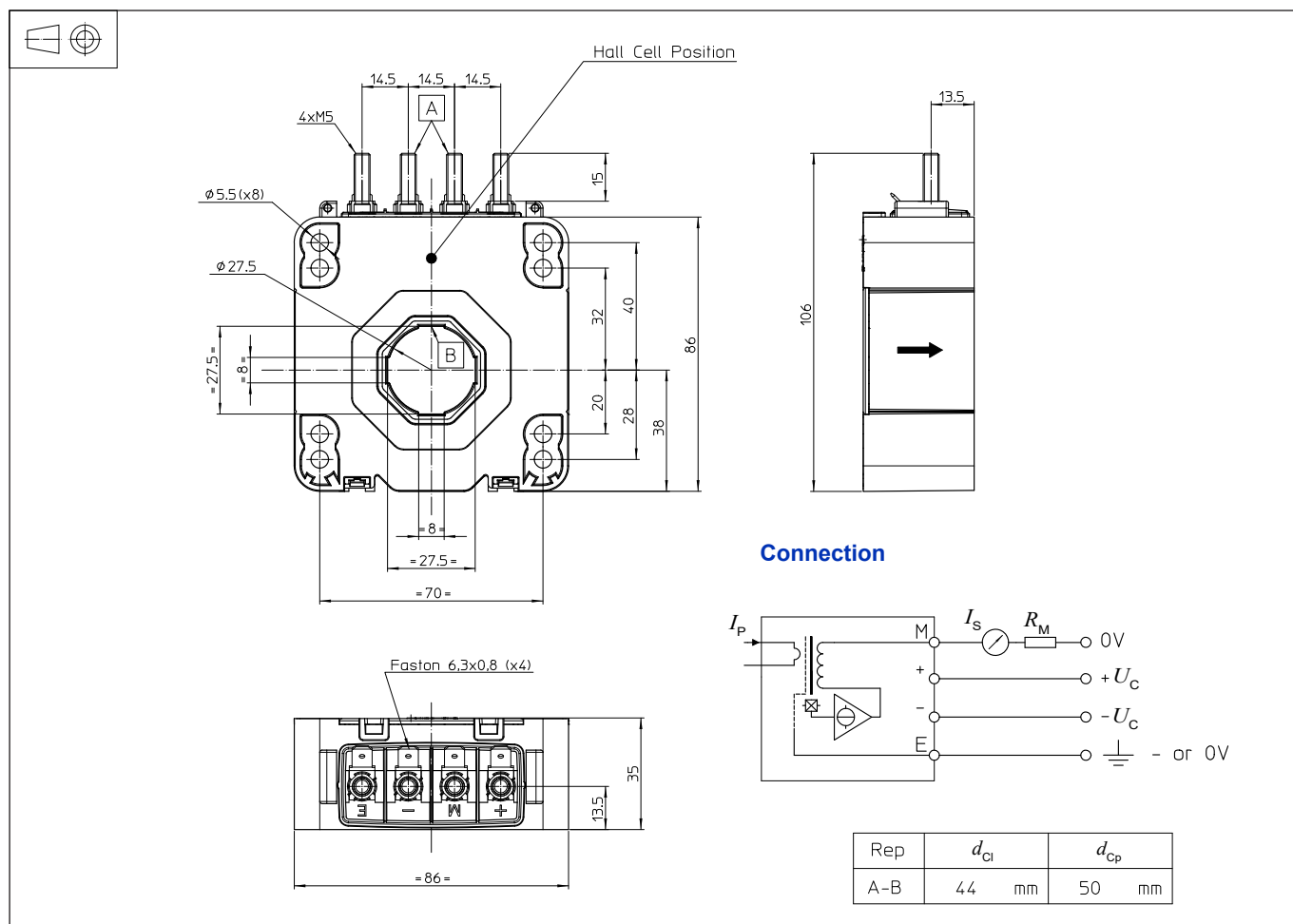

Mechanical characteristics

- General tolerance ± 1 mm
- Transducer fastening 8 holes $\phi 5.5$ mm
4 M5 steel screws
Recommended fastening torque 3.4 Nm
- Primary through-hole $\phi 27.5$ mm
- Connection of secondary 4 M5 threaded studs
Recommended fastening torque 2.2 Nm
Faston 6.3×0.8 mm

Remarks

- I_S is positive when I_P flows in the direction of the arrow.
- Temperature of the primary conductor should not exceed 100 °C.
- Installation of the transducer must be done unless otherwise specified on the datasheet, according to LEM Transducer Generic Mounting Rules. Please refer to LEM document N°ANE120504 available on our Web site: <https://www.lem.com/en/file/3137/download/>.
- Dynamic performances (di/dt and delay time) are best with a single bar completely filling the primary hole.
- This is a standard model. For different versions (supply voltages, turns ratios, unidirectional measurements...), please contact us.

LTC 350-S / Mechanical adaptation accessories

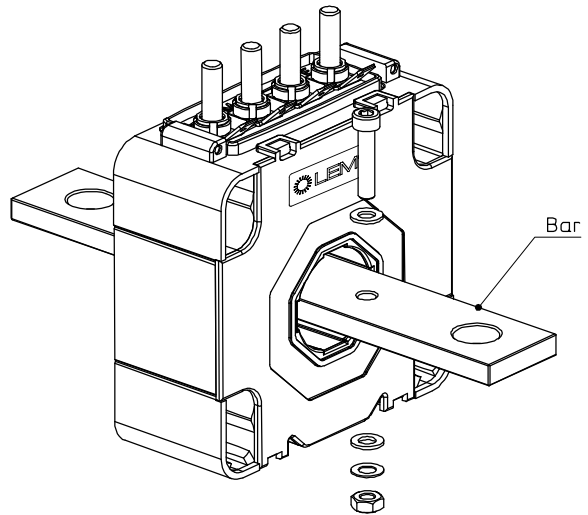
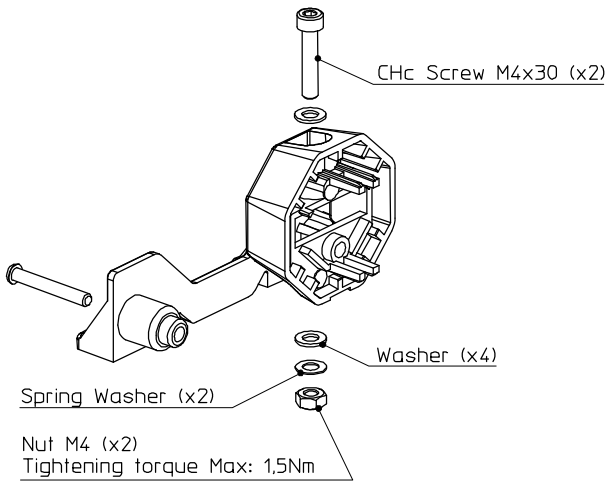

Other possibilities of assembly
of Feet, Bar and Clamps

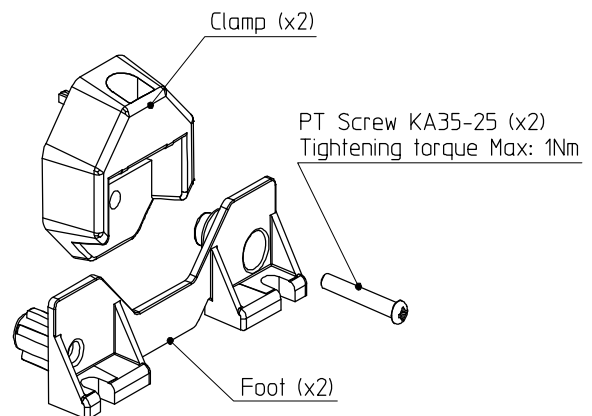
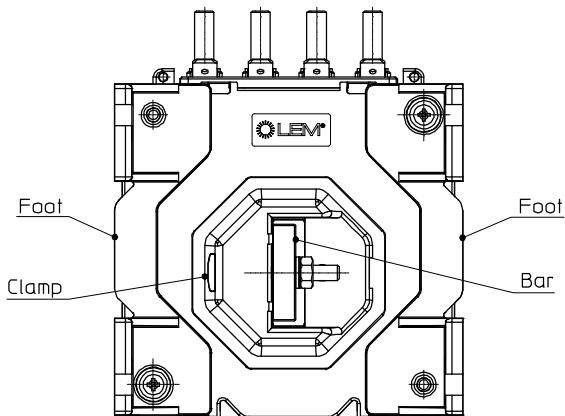

Accessories	References
Busbar Kit * (busbar : 155 × 25 × 6 mm)	93.34.41.100.0
Busbar Kit * (busbar : 112 × 25 × 6 mm)	93.34.41.101.0
Busbar Fastening Kit **	93.34.41.200.0
Feet fixing Kit ***	93.34.43.100.0

* including all the necessary for its mounting
such as screws, washers, nuts, 2 clamps,
busbar.

** as with * but without the busbar.

*** including screws and 2 feet.



RMS voltage value for partial discharge extinction depends on the busbar.
Refer to the datasheet of the corresponding product.