

# Voltage Transducer LV 100-2000/SP5

For the electronic measurement of voltages: DC, AC, pulsed..., with galvanic separation between the primary circuit and the secondary circuit.

$$U_{PN} = 2000 \text{ V}$$

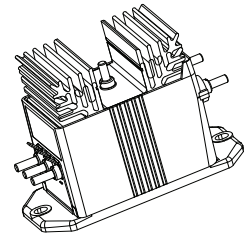

## Electrical data

$U_{PN}$	Primary nominal RMS voltage	2000	V			
$U_{PM}$	Primary voltage, measuring range	0 ... $\pm 3000$	V			
$I_{PN}$	Primary nominal RMS current	5	mA			
$R_M$	Measuring resistance	$R_{M \min}$	$R_{M \max}$			
		with $\pm 15 \text{ V}$	@ $\pm 2000 \text{ V}_{\max}$	0	200	$\Omega$
			@ $\pm 3000 \text{ V}_{\max}$	0	70	$\Omega$
		with $\pm 24 \text{ V}$	@ $\pm 2000 \text{ V}_{\max}$	60	360	$\Omega$
		@ $\pm 3000 \text{ V}_{\max}$	60	150	$\Omega$	
$I_{SN}$	Secondary nominal RMS current	50	mA			
$S$	Sensitivity	25	$\mu\text{A/V}$			
$U_C$	Supply voltage ( $\pm 5 \%$ )	$\pm 15 \dots 24$	V			
$I_C$	Current consumption ( $\pm 1 \text{ mA}$ )	$< 37 (@ \pm 24 \text{ V}) + I_S$	mA			

## Accuracy - Dynamic performance data

$\varepsilon_{\text{tot}}$	Total error @ $U_{PN}, T_A = 25 \text{ }^\circ\text{C}$	$\pm 0.9$	%	
$\varepsilon_L$	Linearity error	$< 0.1$	%	
$I_O$	Offset current @ $U_P = 0, T_A = 25 \text{ }^\circ\text{C}$	Typ	Max	
			$\pm 0.2$	mA
$I_{OT}$	Temperature variation of $I_O$	$-25 \text{ }^\circ\text{C} \dots +70 \text{ }^\circ\text{C}$	$\pm 0.4$   $\pm 0.6$	mA
$t_{D90}$	Delay time to 90 % of the final output value for $U_{PN}$ step	150	$\mu\text{s}$	

## General data

$T_A$	Ambient operating temperature	$-25 \dots +70$	$^\circ\text{C}$
$T_{\text{Ast}}$	Ambient storage temperature	$-40 \dots +85$	$^\circ\text{C}$
$N_P/N_S$	Turns ratio	20000 : 2000	
$P_P$	Total primary power loss	10	W
$R_P$	Resistance of primary winding @ $T_A = 25 \text{ }^\circ\text{C}$	400	k $\Omega$
$R_S$	Resistance of secondary winding @ $T_A = 70 \text{ }^\circ\text{C}$	55	$\Omega$
$m$	Mass	790	g
	Standard <sup>1)</sup>	EN 50155: 2017	

**Notes:** Standard IEC 61000-4-6 with criteria A < 20 %  
<sup>1)</sup> Additional information available on request.

## Features

- Closed loop (compensated) voltage transducer using the Hall effect
- Insulating plastic case recognized according to UL 94-V0
- Primary resistor – incorporated within the housing.

## Special features

- $U_C = \pm 15 \dots 24 (\pm 5 \%) \text{ V}$
- $U_d = 9 \text{ kV}$
- $T_A = -25 \text{ }^\circ\text{C} \dots +70 \text{ }^\circ\text{C}$

## Advantages

- Excellent accuracy
- Very good linearity
- Low temperature drift
- Optimized delay time
- Wide frequency bandwidth
- High immunity to external interference.

## Applications

- Single or three phase inverters
- Propulsion and braking choppers
- Propulsion converters
- Auxiliary converters
- Battery chargers.

## Application domain

- Railway (fixed installations and onboard).

## Voltage Transducer LV 100-2000/SP5

### Insulation coordination

$U_d$	RMS voltage for AC insulation test, 50 Hz, 1 min	9 Min	kV
$d_{cp}$	Creepage distance	55.12	mm
$d_{cl}$	Clearance	27.9	mm
$CTI$	Comparative tracking index (group I)	600	

### Safety



This transducer must be used in electric/electronic equipment with respect to applicable standards and safety requirements in accordance with the manufacturer's operating instructions.



Caution, risk of electrical shock

When operating the transducer, certain parts of the module can carry hazardous voltage (e.g. primary connections, power supply).

Ignoring this warning can lead to injury and/or cause serious damage.

This transducer is a build-in device, whose conducting parts must be inaccessible after installation.

A protective housing or additional shield could be used.

Main supply must be able to be disconnected.

## Dimensions LV 100-2000/SP5 (in mm)

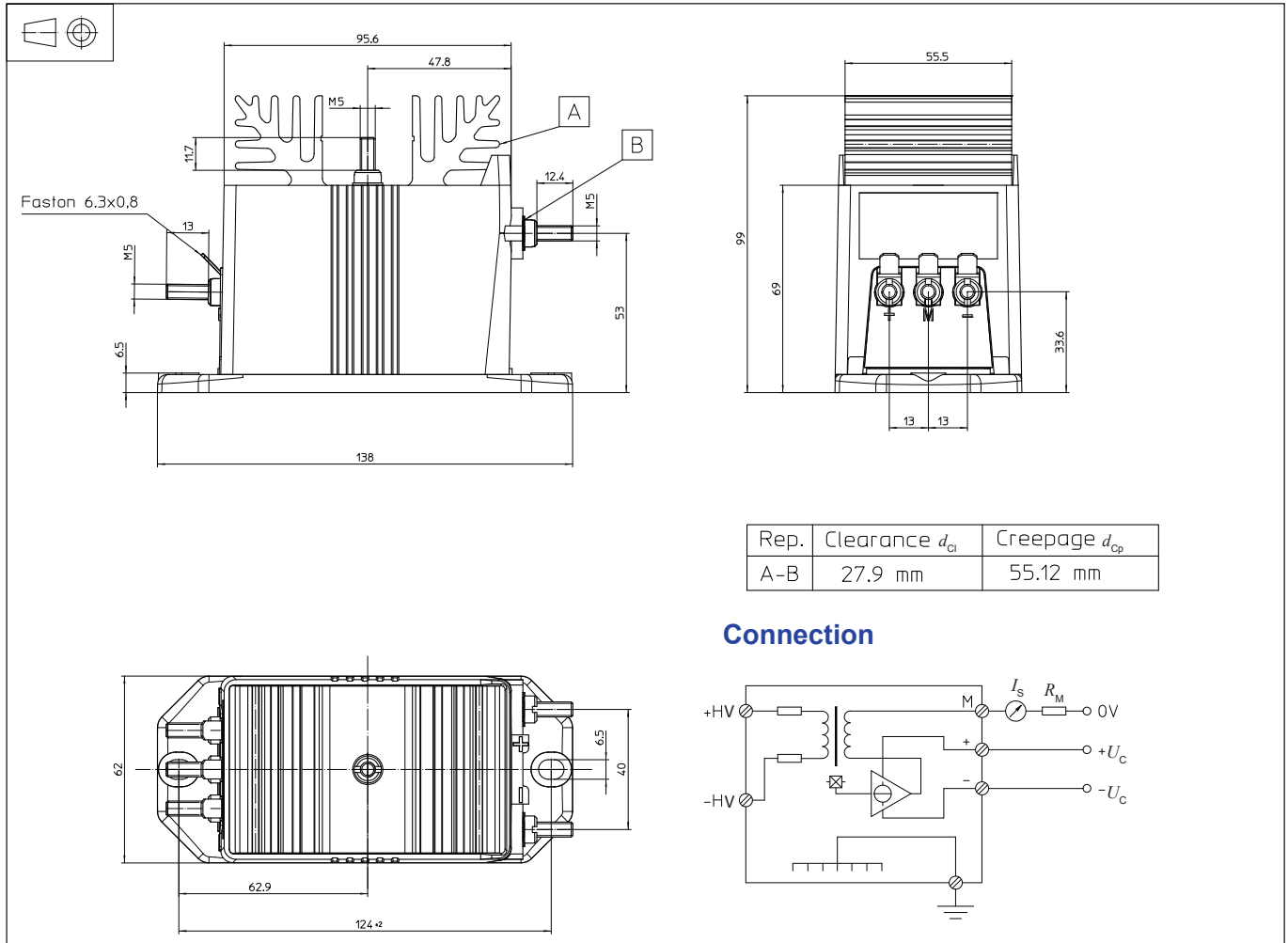

### Connection

### Mechanical characteristics

- General tolerance  $\pm 0.5$  mm
- Transducer fastening
  - 2 holes  $\varnothing 6.5$  mm
  - 2 M6 steel screws
  - Recommended fastening torque 5 N·m
- Connection of primary
  - M5 threaded studs
  - Recommended fastening torque 2.2 N·m
- Connection of secondary
  - Faston 6.3 x 0.8 mm
- Connection of ground
  - M5 threaded studs
  - Recommended fastening torque 2.2 N·m

### Remarks

- $I_s$  is positive when  $U_p$  is applied on terminal +HV.
- The primary circuit of the transducer must be linked to the connections where the voltage has to be measured.
- Installation of the transducer must be done unless otherwise specified on the datasheet, according to LEM Transducer Generic Mounting Rules. Please refer to LEM document N°ANE120504 available on our Web site: <https://www.lem.com/en/file/3137/download/>.